

# AEVT150 Series DC Contactor Specification



## Application

AEVT150 series DC contactor is used for electric vehicle, hybrid electric vehicle, renewable energy storage, battery charging and fuel battery, solar energy battery, general industrial equipment.



## Features

### HIGH CURRENT AND HIGH VOLTAGE

Utilizing a magnetic arc blow-out design in combination with ceramic sealed / inert gas filled contact chamber allows it to make/break 1500A/450Vdc.

### COMPACT STRUCTURE, LOW NOISE

Contact design yields reduced unit size, low noise while carrying and switching current.

### HIGH SAFETY

There is no arc leakage due to tight sealing.

### HIGH RELIABLE CONTACT

Stable contact resistance no matter how harsh the environment with sealed contacts.

### NO SPECIAL REQUIREMENT FOR MOUNTING

Light weight actuator is less impacted by gravity with no special mounting orientation requirements. Side mounting and bottom mount styles are available.

### VARIOUS APPLICATION

Application includes battery switch and standby equipment, DC power control, circuit protection, etc.

### COMPLY WITH EU ROHS DIRECTIVE (2011/65/EU)

## Nomenclature

Example

AEVT150 –

B

S

Series code:

“AEVT150” = AEVT150 Series

Coil Voltage Code:

“B” = 12 VDC

“C” = 24 VDC

Options:

Blank = Std. Options (Bottom Mount & Polarized Load Terminals)

“S” = Side Mount Version

# AEVT150 Series DC Contactor Specification

## Performance Data

MAIN CONTACT		LIFE	
Contact arrangement	1 For X (SPST-NO DM)	50A@450VDC	20,000 cycles
Rated Operating Voltage	450VDC	150A@450VDC	5,000 cycles
Continuous (Carry) Current	150A (65°C)	Mechanical life	200,000 cycles
Short term	225A (10min, 50mm <sup>2</sup> wire) 320A (2min, 50mm <sup>2</sup> wire)		
Max short circuit current	1500A @450VDC, 1 cycle *1		
Dielectric Withstanding Voltage	Between Contacts: 3000VDC, ≤1mA  Contact to Coil: 2,200Vrms, ≤1mA		
Insulation Resistance	Terminal to Terminal/Terminal to coil ≥100 MΩ@500Vdc		
Voltage Drop (@100A)	≤100mV		
ENVIRONMENTAL DATA		OPERATE / RELEASE TIME	
Shock, 11ms ½ sine, operating	20G Peak	Close (includes bounce)	30ms, Max. Bounce 5ms Max.
Vibration, Sine, Peak, 5G	10 to 2,000Hz	Release	10ms, Max
Operating Ambient Temperature	-40 to +85°C		
Altitude	<4000m		
Weight	0.73 lb (0.33kg)		
COIL DATA			
Rated Operating Voltage	12VDC	24VDC	
Max Voltage	15VDC	28VDC	
Pickup voltage (Max.)	9VDC	18VDC	
Dropout voltage (Min.)	1.2VDC	2.4VDC	
Coil power	6W	6W	
Inrush Current (Max.)	500mA	250mA	

**Note:**

\*1 Does not meet dielectric & IR after test.

# AEVT150 Series DC Contactor Specification

## Electrical life

### Estimated Make & Break Power Switching Ratings

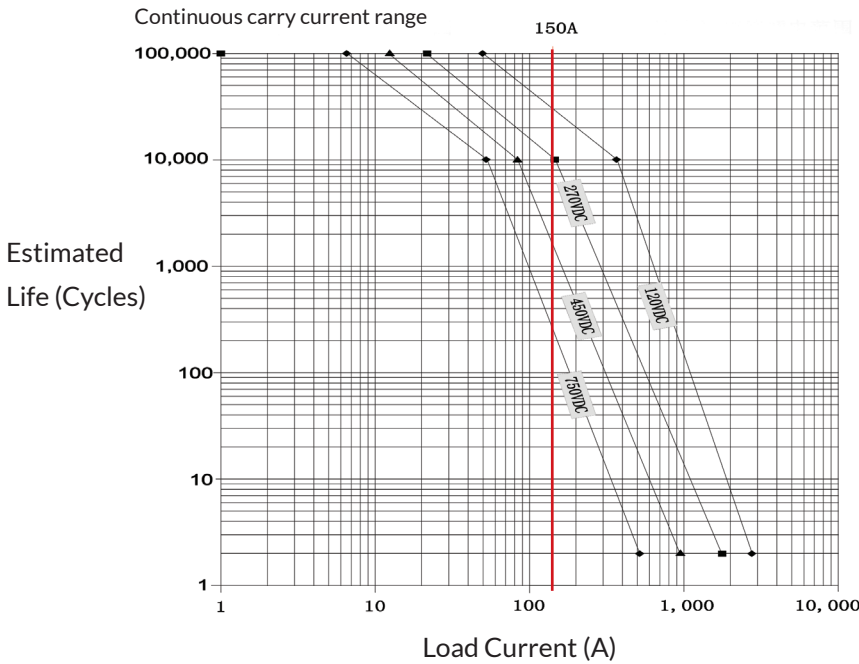

### Note:

Estimates based on extrapolated data. User is encouraged to confirm performance in application.

## Electrical Load Life Ratings for Typical EV Applications

MAKE/BREAK LIFE CAPACITIVE & RESISTIVE LOADS AT 320VDC*1*2	
@90% pre-charge (make only), see chart below	30,000 cycles
@Min 80% pre-charge (make only), see chart below	50 cycles

### Note:

\*1: Resistive load includes L=25uH. Load @2500A, test @200uH

\*2: Life based on projected Weibull Life with 95% reliability.

# AEVT150 Series DC Contactor Specification

## AEVT150 Capacitive Make Test Curves for Pre-Charged Motor Controller

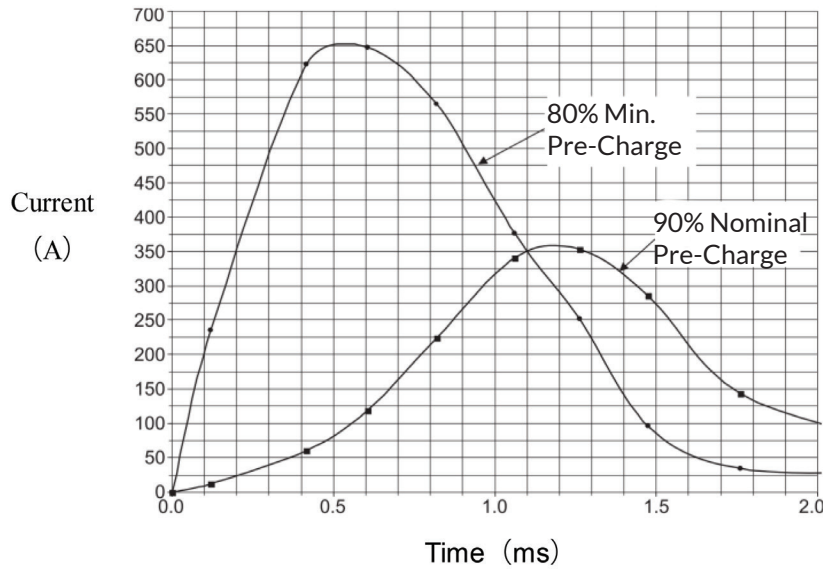

## Outline Dimensions: inches (mm)

Bottom mount:

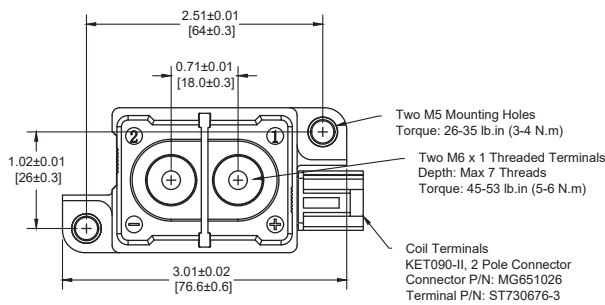

Side mount:

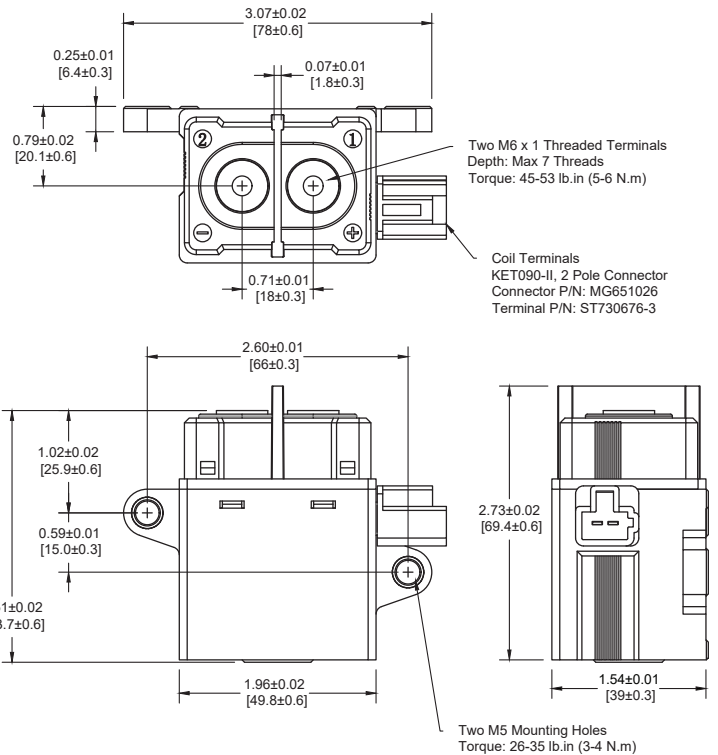

# AEVT150 Series DC Contactor Specification

## Application Note:

1. Be sure to use washer to prevent screws from loosening, all the terminals or copper bar must be in direct contact with the contactor's terminals. Screw tightening torque is specified below. Exceeding the maximum torque can lead to product failure.
  - Contact torque (M6): 45 - 53 lb.in (5 - 6 N.m) Max. Active length of thread is 7.0 mm
  - Mounting torque: 26 - 35 lb.in (3 - 4 N.m)
2. Contact terminals are polarized so refer to drawing during connecting. We suggest using a varistor rather than diode as a surge protector.
3. Do not use if dropped.
4. Avoid installing in a strong magnetic field (close to a transformer or magnet), or near a heat source.
5. Electrical life  
Use per load capability and life cycle limits so as not to cause a function failure (treat the contactor as a product with specified life and replace it when necessary). It is possible to make parts burn around the contactor once operating failure occurs. It is necessary to take layout into account and to make sure power shall be cut off within 1 second.
6. Lifetime of internal gas diffusion  
The contactor is sealed and filled with gas, lifetime of gas diffusion is determined by temperature in contact chamber (ambient temperature + temperature generated by contact operation). Operate only in an ambient temperature from -40 to +85 °C.
7. Avoid debris or oil contamination on the main terminals to optimize contact and avoid excess heat generation.