

PART NUMBER	REVISION	DESCRIPTION	FEED TYPE
2266063-1	B	FINE CRIMP HEIGHT ADJUST	MECHANICAL
2266063-2	B	FINE CRIMP HEIGHT ADJUST	PNEUMATIC
7-2266063-1	B	MECHANICAL AND CRIMP TOOLING KIT	MECHANICAL
7-2266063-2	B	PNEUMATIC AND CRIMP TOOLING KIT	PNEUMATIC
7-2266063-7	A	CRIMP TOOLING KIT	-

ATLANTIC VERSION TERMINATOR INTERFACE ADAPTER

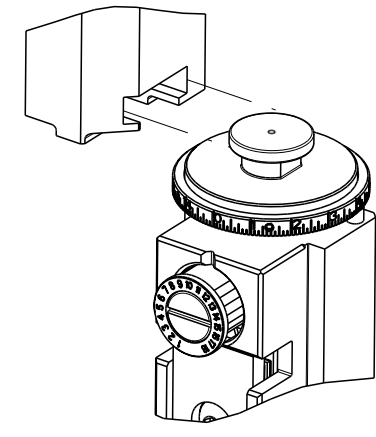

APPLICATOR DATA		
CRIMP	SIZE	TYPE
WIRE	1.98 mm [.078]	F
INSUL	2.44 mm [.096]	F

APPLICATOR INSTRUCTIONS  
408-35042

TERMINAL DATA: CINCH TERMINAL		CINCH CRIMP SPECIFICATION	
TERMINAL NAME: FEMALE TERMINAL BIR 16/20 AWG UNIVERSAL			
WIRE STRIP LENGTH		INSULATION DIAMETER RANGE	
4.05-4.65 mm [.159-.183 IN]		Ø1.96-2.34 mm [.077-.092 IN]	
TERMINAL APPLICATION SPECIFICATION	4250000872S Rev J		
TERMINALS APPLIED			
TE TERMINAL	CINCH TERMINAL	TE TERMINAL	CINCH TERMINAL
1949683-1	425 00 00 872		

WIRE SIZE	CRIMP HEIGHT mm [INCH]	CRIMP HEIGHT REFERENCE SETTING
5 0.80mm2	1.20+/-0.03 [.047+/- .001]	6.9
6 0.80mm2	1.18+/-0.03 [.046+/- .001]	7.1
0.50mm2	1.10+/-0.03 [.043+/- .001]	7.8

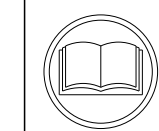

- 1 RECOMMENDED SPARE PARTS
  - 2 REFER TO SUPPLIED INSTRUCTION SHEET FOR CLEANING, LUBRICATION AND STORAGE OF APPLICATOR.
  - 3 APPLY PART NUMBER 2-23419-6 LOCTITE TO THREADS OF ITEM 242.
  - 4 CRIMP HEIGHT REFERENCE SETTING WAS THE SETTING USED WHEN THE APPLICATOR WAS QUALIFIED AT THE FACTORY. ADJUSTMENT MAY BE NECESSARY WHEN RUNNING APPLICATOR IN THE FIELD.
  - 5 NUMBER OF STRANDS IS TO BE 19.
  - 6 NUMBER OF STRANDS IS TO BE 16.
6. UNLESS SPECIFIED OTHERWISE TORQUE VALUES SHALL BE USED PER DOCUMENT, 101-35000.

**\*WARNING**  
ON INSTALLATION, SET WIRE DISC TO CRIMP HEIGHT REFERENCE SETTING FOR LARGEST WIRE SIZE. CRIMP HEIGHT REFERENCE SETTINGS GREATER THAN THE VALUE SHOWN MAY CAUSE DAMAGE TO THE CRIMP TOOLING, REFER TO THE INSTRUCTION SHEET FOR PROPER SETUP AND ADJUSTMENTS.

LOC	DIST	REVISIONS					
		#	LY#	DESCRIPTION	DATE	OWN	APVD
A	66	A		RELEASED	23DEC2013	LG	GB
		A1		ECR-17-002904	1MAR2017	RS	LZ

-	1	-	1	-	2119640-1	PUSH ROD, AIR FEED	250	
-	1	-	1	-	1803259-1	BUSHING, FLANGED	249	
-	1	-	1	-	2119641-1	FEED CAM, AIR FEED	248	
-	1	1	1	1	2119082-4	CAM, SNAIL, INSULATION ADJUSTMENT	244	
-	1	1	1	1	2079764-1	WASHER, WAVE SPRING, CREST-TO-CREST	243	
-	1	1	1	1	2119083-1	RETAINER, INSULATION DIAL	242	
-	1	1	1	1	7-18023-7	SCR, SKT HD CAP M3 X 4.0	241	
-	-	1	-	1	2119580-1	MECHANICAL FEED ASSEMBLY	239	
-	1	-	1	-	2063440-1	AIR FEED MODULE	238	
-	2	-	2	-	21045-3	RING, RETAIN, EXTERN, 3/16 CRESCENT	172	
-	REF	REF	REF	REF	994970-2	COUNTER, MAGNETIC	164	
-	1	-	1	-	240638-1	SPRING, FEED FINGER	163	
-	1	-	1	-	3-23627-7	PIN, RETAIN, GRVD, 3/16 X .854	137	
-	1	-	1	-	2119799-1	HOLDER, FEED FINGER, AF	136	
-	1	1	1	1	1-18028-2	WASHER, FLAT, REG M4	119	
-	1	1	1	1	2844908-1	SCREW, LOCKING	99	
-	1	1	1	1	2844907-1	POST, LOCKING	98	
-	1	1	1	1	455888-6	SPACER, CRIMPER	82	
-	1	1	1	1	5-547505-2	SPRING, COMPRESSION	77	
-	1	1	1	1	854769-4	HOLDER, INS	74	
-	1	1	1	1	1803607-1	DOCUMENTATION PACKAGE	71	
-	1	1	1	1	2119740-1	TAG, IDENTIFICATION	67	
-	2	2	2	2	2168078-1	SCREW, DRIVE, RH, RoHS, 2 x .188	66	
-	1	1	1	1	2168083-2	SCR, SKT HD CAP, RoHS, M4 X 8.0	60	
-	1	1	1	1	5-18022-5	SCR, HEX HD CAP, M4 X 6.0	59	
-	1	1	1	1	21028-2	PIN, SLOTTED SPRING .062 X .250	58	
-	1	1	1	1	1333240-3	PAWL, FEED (SPECIAL)	56	
-	4	4	4	4	2168083-3	SCR, SKT HD CAP, RoHS, M4 X 12.0	54	
-	2	2	2	2	2168083-3	SCR, SKT HD CAP, RoHS, M4 X 12.0	53	
-	1	1	1	1	5018030-1	NUT, HEX, REG, RoHS, M3	52	
-	1	1	1	1	811242-5	BUMPER, HOLD DOWN	51	
-	1	1	1	1	690753-2	SPACER, TONKER	50	
-	1	2	1	2	18023-9	SCR, SKT HD CAP M4 X 6.0	49	
-	-	1	-	1	2119652-1	FEED CAM, PRE FEED	48	
-	-	1	-	1	2119653-1	FEED CAM, POST FEED	47	
-	1	1	1	1	1803583-9	APPLICATOR BASIC ASSEMBLY, SF	46	
-	1	1	1	1	1803515-1	RAM ASSEMBLY, SF ATLANTIC	44	
-	1	1	1	1	1803602-1	SCR, BHSC, RoHS (M8 X 25)	41	
-	1	1	1	1	1752356-6	SUPPORT, TERMINAL	34	
-	2	2	2	2	2079383-5	SCR, BHSC, RoHS (M4 X 20)	33	
-	2	2	2	2	2-2844962-8	SPACER, CYLINDRICAL, STRIP GUIDE	30	
-	1	1	1	1	2844992-1	ASSEMBLY, STRIP GUIDE	29	
-	1	1	1	1	455888-3	SPACER, CRIMPER	28	
-	1	1	1	1	1320928-2	STRIP GUIDE	24	
-	1	1	1	1	2168083-2	SCR, SKT HD CAP, RoHS, M4 X 8.0	21	
-	1	1	1	1	1-18028-2	WASHER, FLAT, REG M4	20	
-	1	1	1	1	2119533-1	STRIPPER, SIDE FEED	19	
-	1	1	1	1	2119806-1	INSERT, SHEAR	13	
-	1	1	1	1	3-22280-3	SPRING, COMPRESSION	12	
-	1	1	1	1	1-356885-4	STOP, SHEAR	11	
-	1	1	1	1	2119805-1	SHEAR HOLDER, FRONT	10	
-	1	1	1	1	1803095-1	FLOATING SHEAR, FRONT	9	
-	1	2	2	1	1803055-5	ANVIL, COMBINATION	8	
-	1	1	1	1	240641-9	SPACER	7	
-	-	-	-	-	-	-	6	
-	1	1	1	1	2119780-9	DEPRESSOR, SHEAR	5	
-	1	1	1	1	2-238011-2	BLOCK, CRIMPER SPACER	4	
-	1	2	2	1	4-1633962-5	CRIMPER, INSULATION F PREMIUM	3	
-	1	1	1	1	455888-3	SPACER, CRIMPER	2	
-	1	2	2	1	2-1490019-4	CRIMPER, WIRE PREMIUM	1	
-	77	-72	-71	-2	-1	PART NO	DESCRIPTION	ITEM NO

ATLANTIC VERSION  
Shown on sheets 1 of 4 & 2 of 4  
(Pacific version shown on sheets 3 of 4 & 4 of 4)

DIMENSIONS:		TOLERANCES UNLESS OTHERWISE SPECIFIED:		OWN: L. GROSS 09OCT2013		TE Connectivity	
mm		0 PLC ±		CHK: T. ELBIN 09OCT2013		Harrisburg, PA 17105-3608	
		1 PLC ±		APVD: M. CLIFFORD 09OCT2013		NAME: Ocean Side Feed Applicator	
		2 PLC ±		PRODUCT SPEC		SIZE: CAGE CODE: DRAWING NO: RESTRICTED TO	
		3 PLC ±		APPLICATION SPEC		A1 00779 ©=2266063	
		4 PLC ±		WEIGHT		SCALE: 1:2 SHEET 1 OF 4 REV B	
		ANGLES FINISH		MATERIAL		Customer Accessible Production Drawing	

LOC	DIST	REVISIONS			
		REV	DATE	BY	APPV
A	66	-	SEE SHEET 1	-	-

# FEED TYPE MECHANICAL

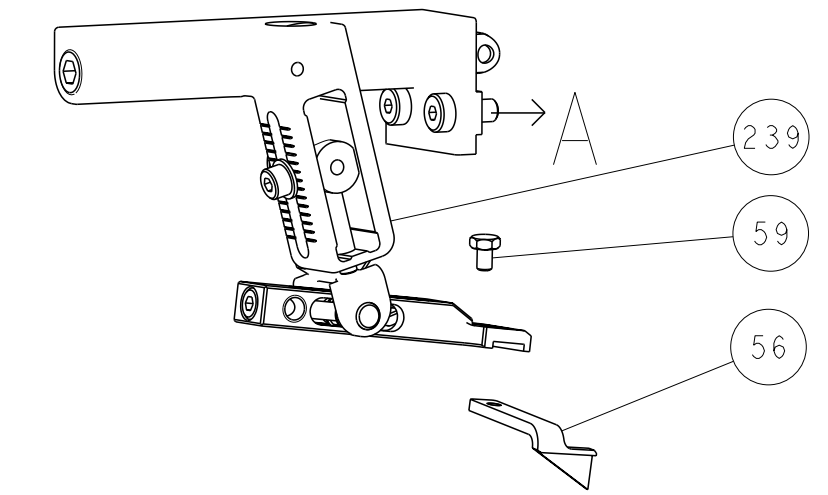

# PNEUMATIC

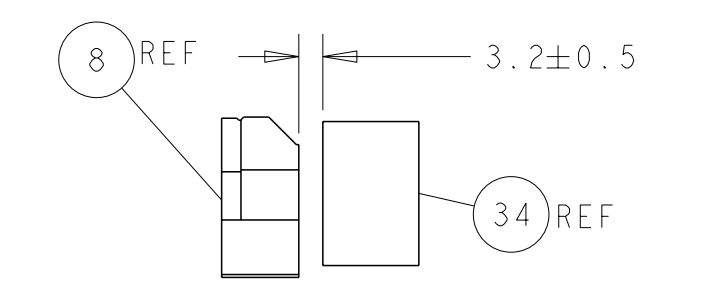
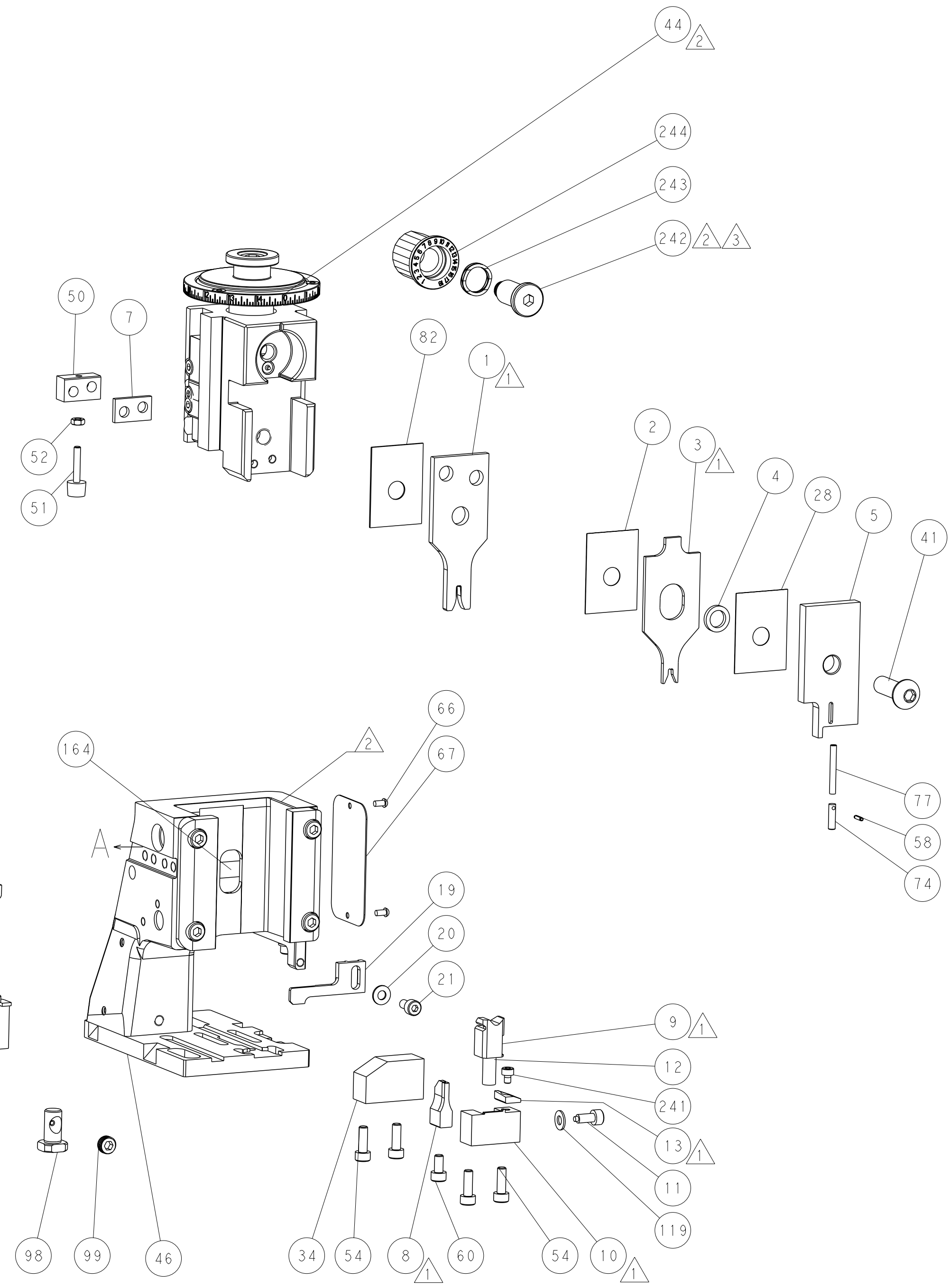
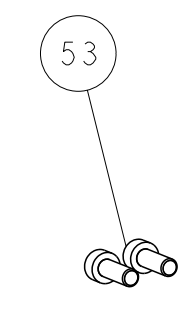
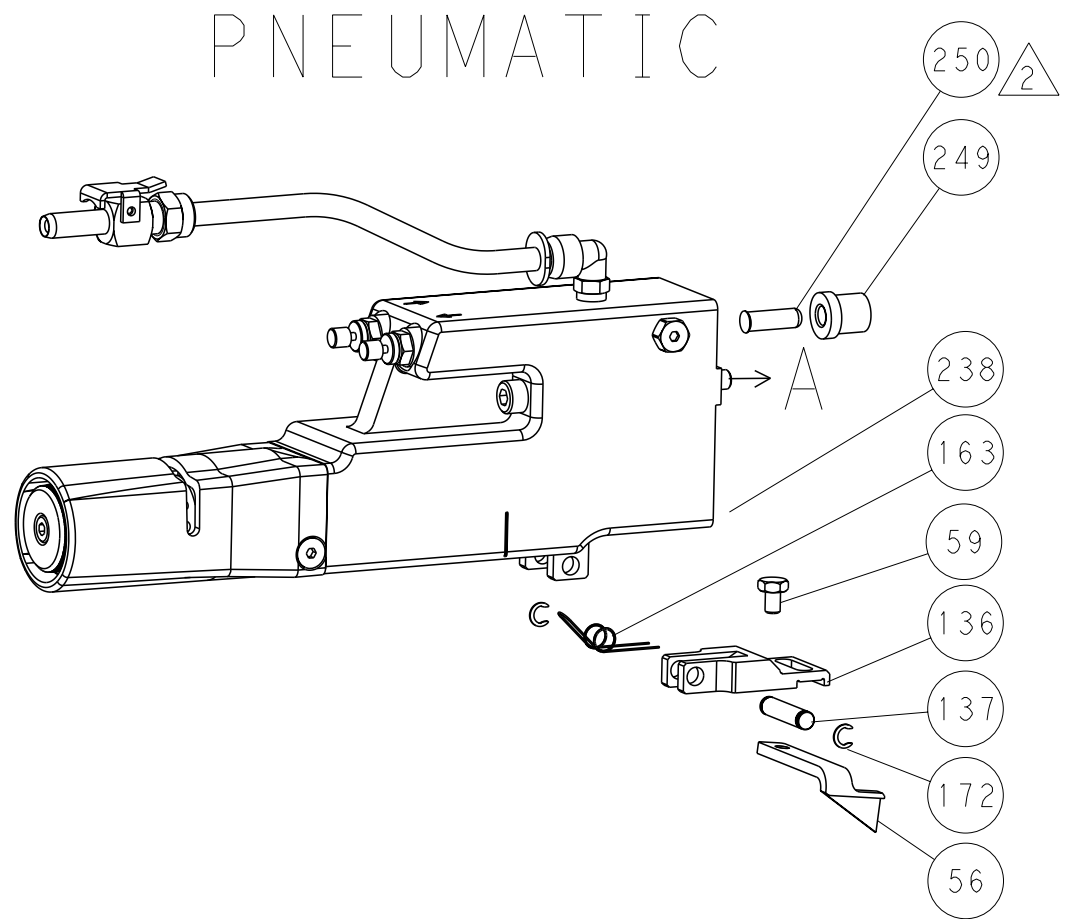

TERMINAL SUPPORT LOCATION

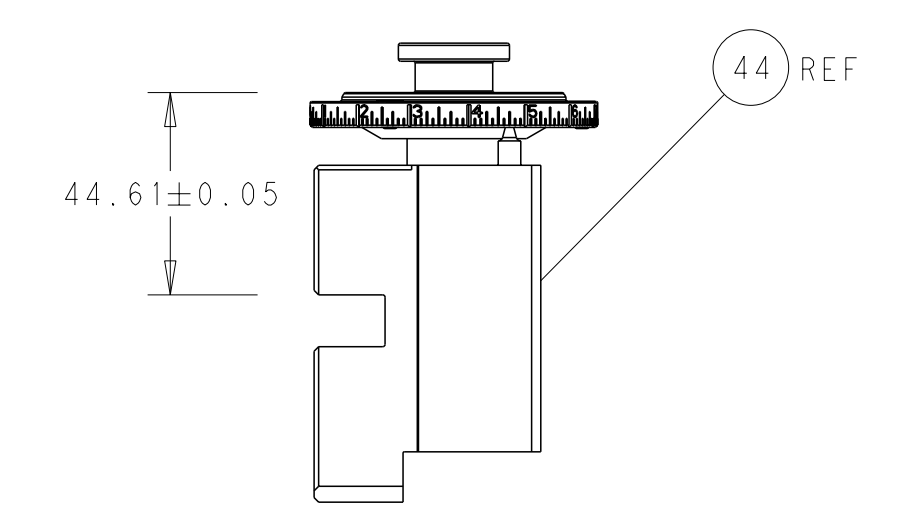

RAM SET-UP

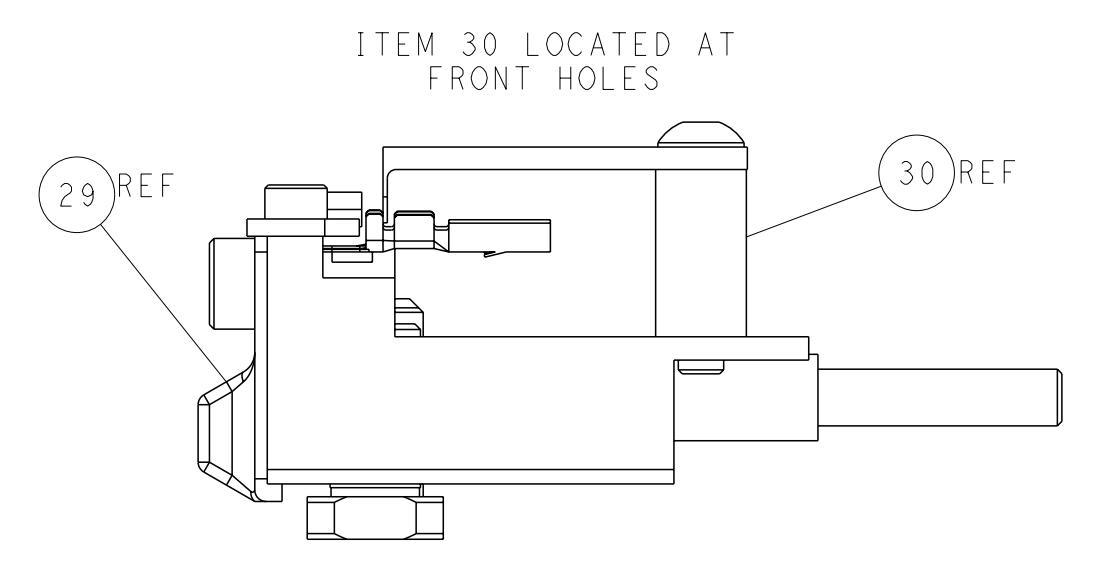

FEED TRACK POSITION GUIDE BY INSULATION BARREL

# CAM POSITIONS

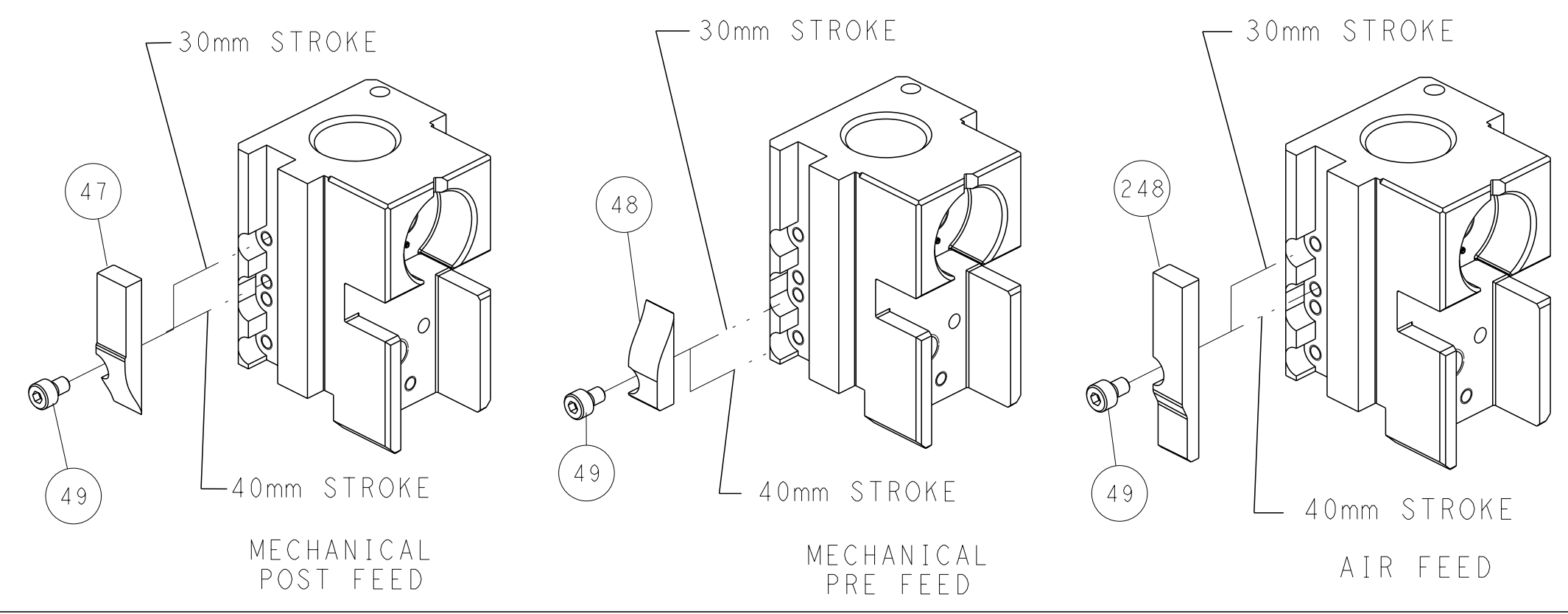

**ATLANTIC VERSION**  
 Shown on sheets 1 of 4 & 2 of 4  
 (Pacific version shown on sheets 3 of 4 & 4 of 4)

<small>THIS DRAWING IS A CONTROLLED DOCUMENT FOR TYCO ELECTRONICS CORPORATION. IT IS SUBJECT TO CHANGE AND THE CONTROL AND REVISIONS DISPOSITION SHOULD BE CONTACTED FOR THE LATEST REVISION.</small>		OWN: L. GROSS CDR: T. ELBIN APVD: M. CLIFFORD PRODUCT SPEC: - APPLICATION SPEC: - WEIGHT: - MATERIAL: -	DATE: 09OCT2013 DATE: 09OCT2013 DATE: 09OCT2013 SCALE: 1:2 SHEET: 2 of 4 REV: B	NAME: Ocean Side Feed Applicator SIZE: A1 CAGE CODE: 00779 DRAWING NO: C=2266063 RESTRICTED TO: -
---	--	---	--	---

PART NUMBER	REVISION	DESCRIPTION	FEED TYPE
2-2266063-1	B	FINE CRIMP HEIGHT ADJUST	MECHANICAL
2-2266063-2	B	FINE CRIMP HEIGHT ADJUST	PNEUMATIC
7-2266063-7	A	CRIMP TOOLING KIT	-

PACIFIC VERSION TERMINATOR  
 INTERFACE ADAPTER

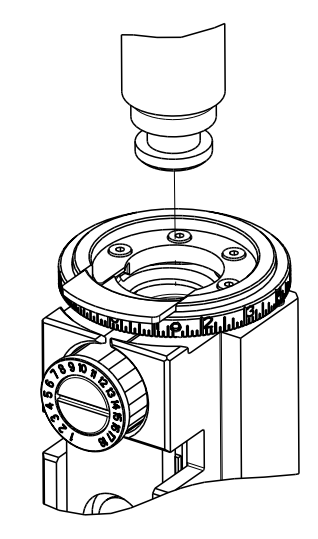

APPLICATOR DATA		
CRIMP	SIZE	TYPE
WIRE	1.98 mm [.078]	F
INSUL	2.44 mm [.096]	F
APPLICATOR INSTRUCTIONS 408-35042		

TERMINAL DATA: CINCH TERMINAL		CINCH CRIMP SPECIFICATION	
TERMINAL NAME: FEMALE TERMINAL BIR 16/20 AWG UNIVERSAL			
WIRE STRIP LENGTH		INSULATION DIAMETER RANGE	
4.05-4.65 mm [.159-.183 IN]		Ø1.96-2.34 mm [.077-.092 IN]	
TERMINAL APPLICATION SPECIFICATION	4250000872S Rev J		
TERMINALS APPLIED			
TE TERMINAL	CINCH TERMINAL	TE TERMINAL	CINCH TERMINAL
1949683-1	425 00 00 872		

WIRE SIZE	CRIMP HEIGHT mm [INCH]	CRIMP HEIGHT REFERENCE SETTING
0.80mm2	1.20 +/- 0.03 [.047 +/- .001]	6.9
0.80mm2	1.18 +/- 0.03 [.046 +/- .001]	7.1
0.50mm2	1.10 +/- 0.03 [.043 +/- .001]	7.8

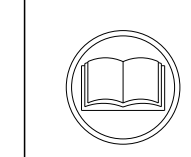

- 1 RECOMMENDED SPARE PARTS
- 2 REFER TO SUPPLIED INSTRUCTION SHEET FOR CLEANING, LUBRICATION AND STORAGE OF APPLICATOR.
- 3 APPLY PART NUMBER 2-23419-6 LOCTITE TO THREADS OF ITEM 242.
- 4 CRIMP HEIGHT REFERENCE SETTING WAS THE SETTING USED WHEN THE APPLICATOR WAS QUALIFIED AT THE FACTORY. ADJUSTMENT MAY BE NECESSARY WHEN RUNNING APPLICATOR IN THE FIELD.
- 5 NUMBER OF STRANDS IS TO BE 19.
- 6 NUMBER OF STRANDS IS TO BE 16.
- 6. UNLESS SPECIFIED OTHERWISE TORQUE VALUES SHALL BE USED PER DOCUMENT, 101-35000.

**\*WARNING**  
 ON INSTALLATION, SET WIRE DISC TO CRIMP HEIGHT REFERENCE SETTING FOR LARGEST WIRE SIZE. CRIMP HEIGHT REFERENCE SETTINGS GREATER THAN THE VALUE SHOWN MAY CAUSE DAMAGE TO THE CRIMP TOOLING. REFER TO THE INSTRUCTION SHEET FOR PROPER SETUP AND ADJUSTMENTS.

LOC	DIST	REVISIONS					
		P	LYR	DESCRIPTION	DATE	OWN	APVD
A	66	-	-	SEE SHEET 1	-	-	-

-	1	-	2119640-1	PUSH ROD, AIR FEED	250
-	1	-	1803259-1	BUSHING, FLANGED	249
-	1	1	2119082-4	CAM, SNAIL, INSULATION ADJUSTMENT	244
-	1	1	2079764-1	WASHER, WAVE SPRING, CREST-TO-CREST	243
3	1	1	2119083-1	RETAINER, INSULATION DIAL	242
-	1	1	7-18023-7	SCR, SKT HD CAP M3 X 4.0	241
-	-	1	2119580-1	MECHANICAL FEED ASSEMBLY	239
-	1	-	2063440-1	AIR FEED MODULE	238
-	2	-	21045-3	RING, RETAIN, EXTERN, 3/16 CRESCENT	172
-	REF	REF	994970-2	COUNTER, MAGNETIC	164
-	1	-	240638-1	SPRING, FEED FINGER	163
-	1	-	2119641-2	FEED CAM, AIR FEED	151
-	1	1	2168083-8	SCR, SKT HD CAP, RoHS, M4 X 16	144
-	4	4	2168083-9	SCR, SKT HD CAP, RoHS, M4 X 20	143
-	-	1	2119653-2	FEED CAM, POST FEED	142
-	1	1	1-1803583-0	APPLICATOR BASIC ASSEMBLY, SF	141
-	1	1	1803516-1	RAM ASSEMBLY, SF PACIFIC	140
-	1	-	3-23627-7	PIN, RETAIN, GRVD, 3/16 X .854	137
-	1	-	2119799-1	HOLDER, FEED FINGER, AF	136
-	1	1	1-18028-2	WASHER, FLAT, REG M4	119
-	1	1	2844908-1	SCREW, LOCKING	99
-	1	1	2844907-1	POST, LOCKING	98
-	1	1	455888-6	SPACER, CRIMPER	82
-	1	1	5-547505-2	SPRING, COMPRESSION	77
-	1	1	854769-4	HOLDER, INS	74
-	1	1	1803607-1	DOCUMENTATION PACKAGE	71
-	1	1	2119740-1	TAG, IDENTIFICATION	67
-	2	2	2168078-1	SCREW, DRIVE, RH, RoHS, 2 x .188	66
-	1	1	5-18022-5	SCR, HEX HD CAP, M4 X 6.0	59
-	1	1	21028-2	PIN, SLOTTED SPRING .062 X .250	58
-	1	1	1333240-3	PAWL, FEED (SPECIAL)	56
-	2	2	2168083-3	SCR, SKT HD CAP, RoHS, M4 X 12.0	53
-	1	1	5018030-1	NUT, HEX, REG, RoHS, M3	52
-	1	1	811242-5	BUMPER, HOLD DOWN	51
-	1	1	690753-2	SPACER, TONKER	50
-	1	2	18023-9	SCR, SKT HD CAP M4 X 6.0	49
-	-	1	2119652-1	FEED CAM, PRE FEED	48
-	1	1	1803602-1	SCR, BHSC, RoHS (M8 X 25)	41
-	1	1	1752356-6	SUPPORT, TERMINAL	34
-	2	2	2079383-5	SCR, BHSC, RoHS (M4 X 20)	33
-	2	2	2-2844962-8	SPACER, CYLINDRICAL, STRIP GUIDE	30
-	1	1	2844992-1	ASSEMBLY, STRIP GUIDE	29
-	1	1	455888-3	SPACER, CRIMPER	28
-	1	1	1320928-2	STRIP GUIDE	24
-	1	1	2168083-2	SCR, SKT HD CAP, RoHS, M4 X 8.0	21
-	1	1	1-18028-2	WASHER, FLAT, REG M4	20
-	1	1	2119533-1	STRIPPER, SIDE FEED	19
-	1	1	2119806-1	INSERT, SHEAR	13
-	1	1	3-22280-3	SPRING, COMPRESSION	12
-	1	1	1-356885-4	STOP, SHEAR	11
-	1	1	2119805-1	SHEAR HOLDER, FRONT	10
-	1	1	1803095-1	FLOATING SHEAR, FRONT	9
1	1	1	1803055-5	ANVIL, COMBINATION	8
-	1	1	240641-9	SPACER	7
-	-	-	-	-	6
-	1	1	2119780-9	DEPRESSOR, SHEAR	5
-	1	1	2-238011-2	BLOCK, CRIMPER SPACER	4
1	1	1	4-1633962-5	CRIMPER, INSULATION F PREMIUM	3
-	1	1	455888-3	SPACER, CRIMPER	2
1	1	1	2-1490019-4	CRIMPER, WIRE PREMIUM	1

PACIFIC VERSION  
 Shown on sheets 3 of 4 & 4 of 4  
 (Atlantic version shown on sheets 1 of 4 & 2 of 4)

DIMENSIONS: mm 		TOLERANCES UNLESS OTHERWISE SPECIFIED: 0 PLC ± 1 PLC ± 2 PLC ± 3 PLC ± 4 PLC ± ANGLES FINISH ±		OWN: L. GROSS 09OCT2013 CHK: T. ELBIN 09OCT2013 APVD: M. CLIFFORD 09OCT2013 PRODUCT SPEC APPLICATION SPEC		NAME: STE TE Connectivity Harrisburg, PA 17105-3608 Ocean Side Feed Applicator	
MATERIAL:		WEIGHT:		SIZE: A1		CAGE CODE: 00779	
				DRAWING NO: 2266063		RESTRICTED TO:	
Customer Accessible Production Drawing				SCALE: 1:2		SHEET 3 of 4 REV B	

LOC		DIST		REVISIONS			
A	66	P	LYR	DESCRIPTION	DATE	OWN	APVD
		-		SEE SHEET 1			

# FEED TYPE MECHANICAL

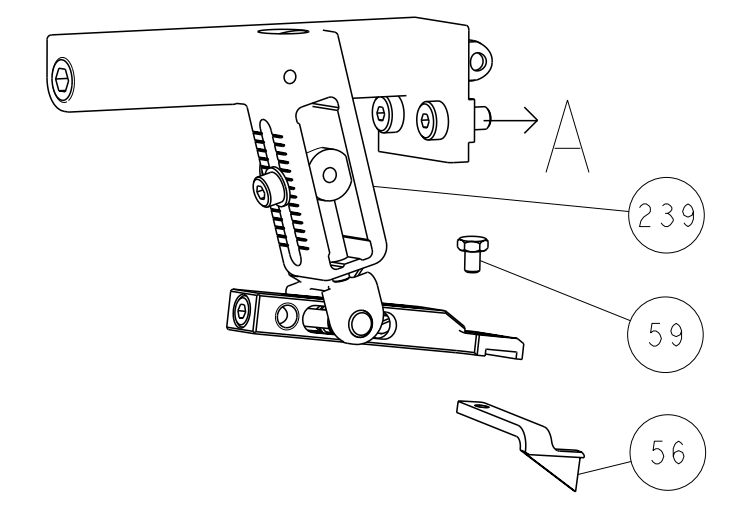

# PNEUMATIC

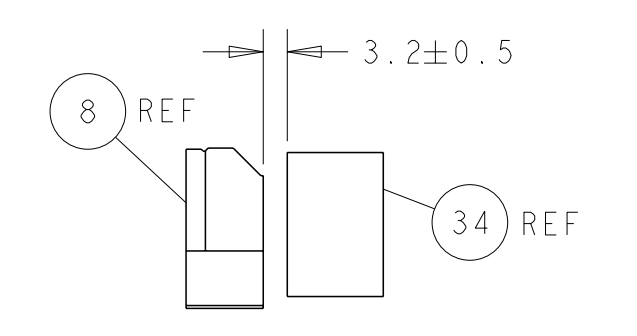
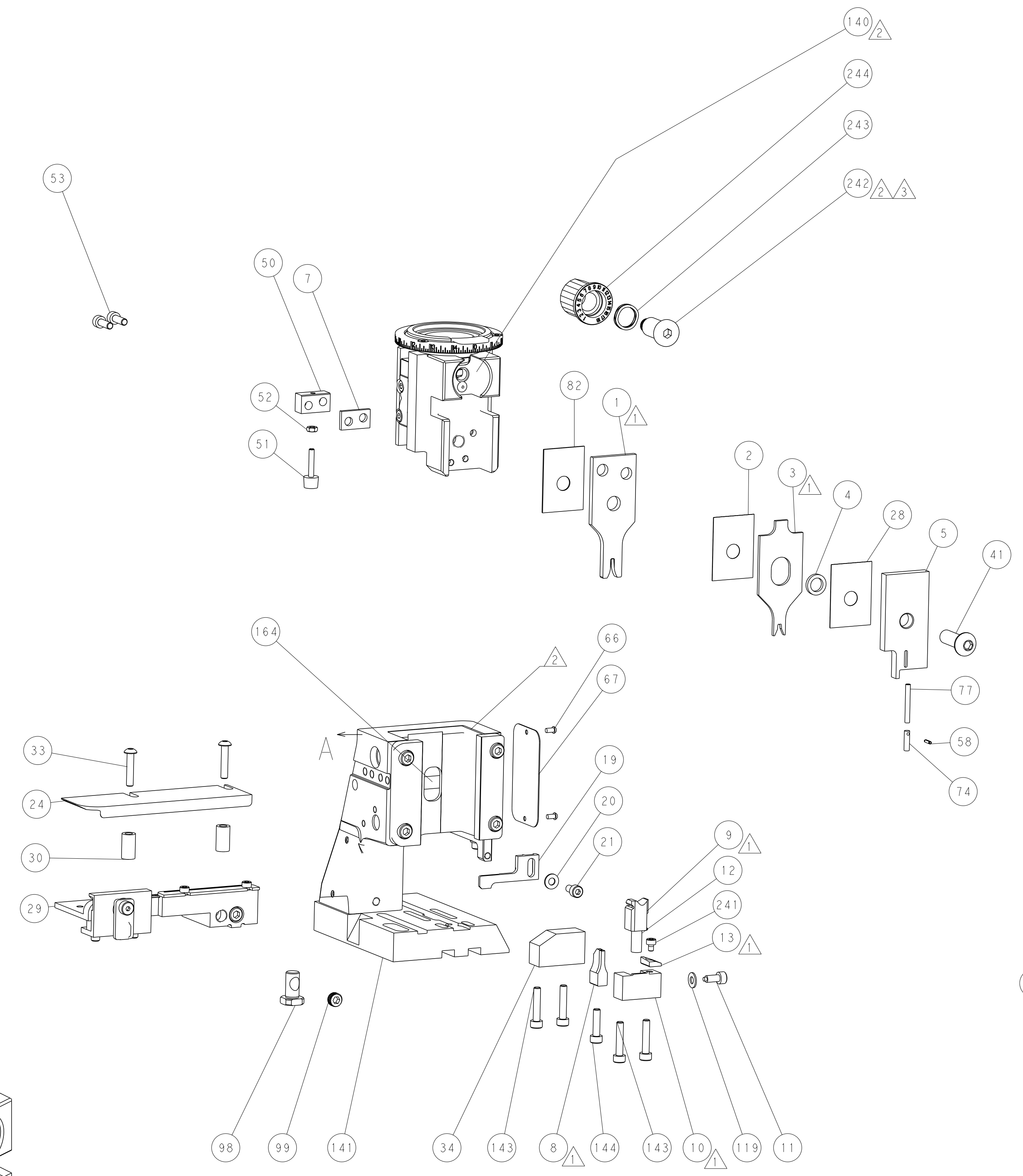
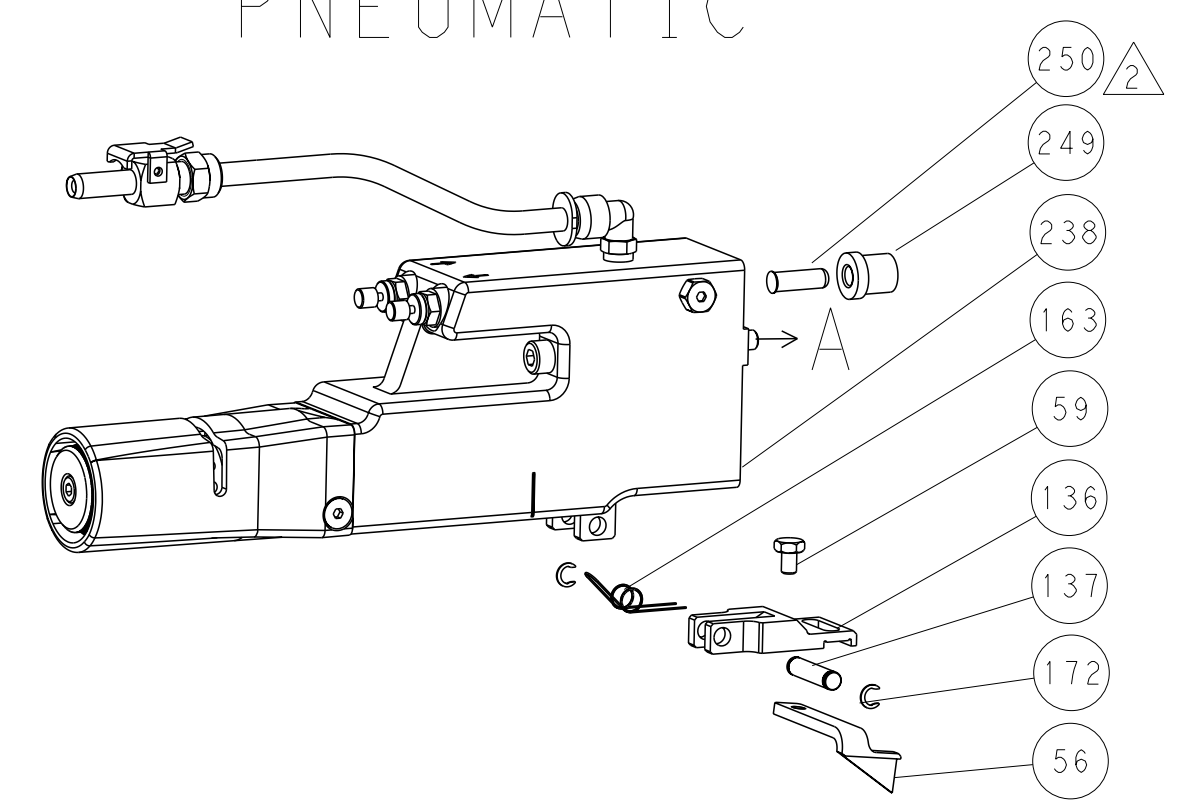

TERMINAL SUPPORT LOCATION

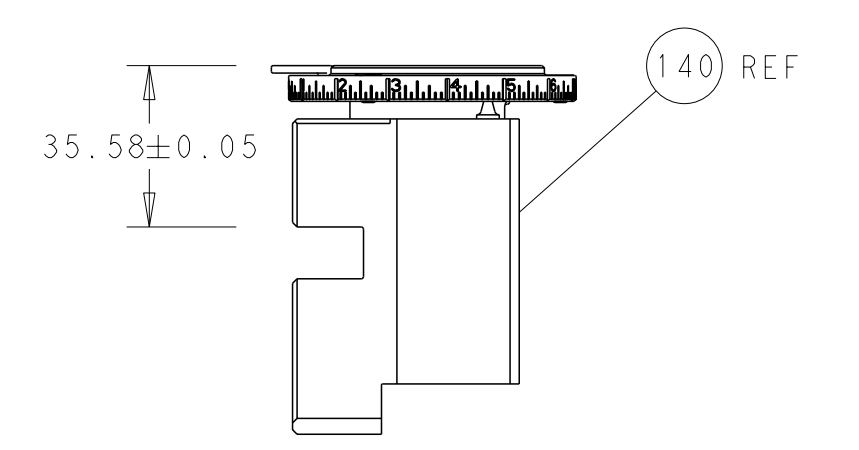

RAM SET-UP

ITEM 30 LOCATED AT FRONT HOLES

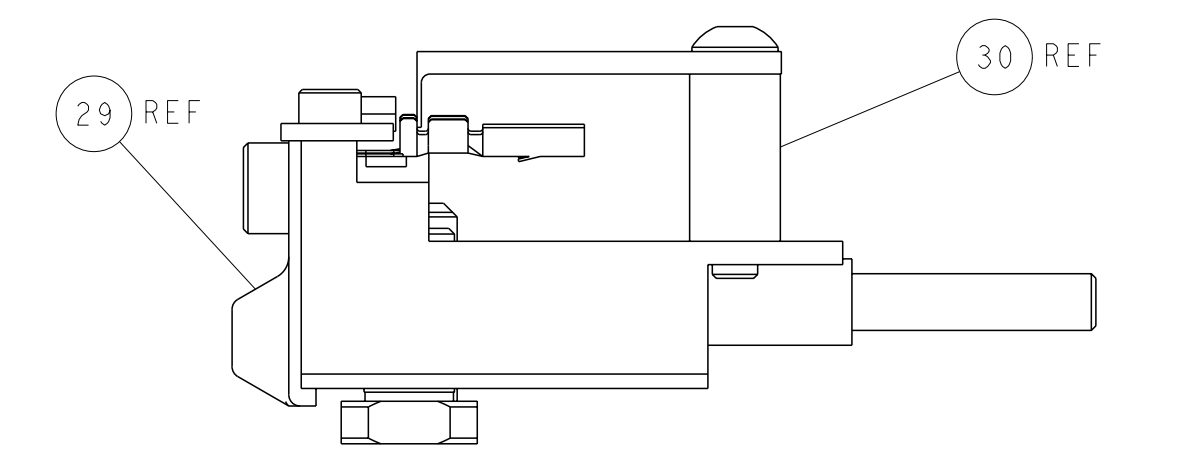

FEED TRACK POSITION GUIDE BY INSULATION BARREL

# CAM POSITIONS

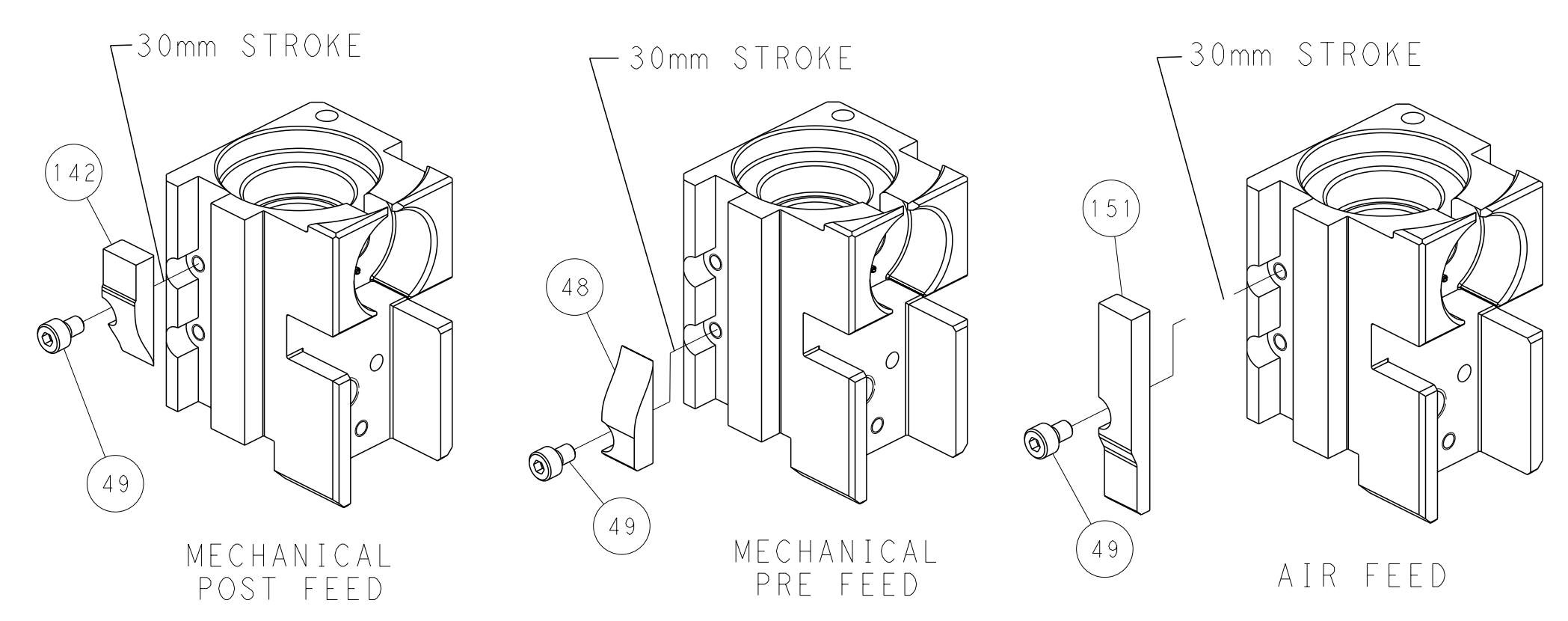

**PACIFIC VERSION**  
 Shown on sheets 3 of 4 & 4 of 4  
 (Atlantic version shown on sheets 1 of 4 & 2 of 4)

<small>THIS DRAWING IS UNPUBLISHED. RELEASED FOR PUBLICATION. IT IS SUBJECT TO CHANGE AND THE USER ASSUMES ALL RESPONSIBILITY FOR THE LATEST REVISION. DIMENSIONS SHOULD BE CONTACTED FOR THE LATEST REVISION.</small>		DWN: L.GROSS 09OCT2013 CHK: T.ELBIN 09OCT2013 APVD: M.CLIFFORD 09OCT2013 PRODUCT SPEC: - APPLICATION SPEC: - WEIGHT: - MATERIAL: -	NAME: Ocean Side Feed Applicator SIZE: A1 CAGE CODE: 00779 DRAWING NO: C=2266063 SCALE: 1:2 SHEET: 4 of 4 REV: B	TE Connectivity Harrisburg, PA 17105-3608
--	--	--	--	--