

WITH MOUNTING CLIPS

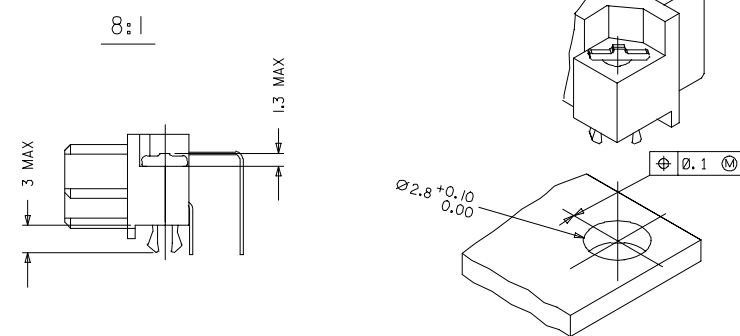

- NOTES:
- MATERIALS: THERMOPLASTIC POLYESTER, GLASS FILLED, UL94V-0. COLOUR: PEBBLE GREY RAL 7032
TERMINAL - PHOSPHOR BRONZE
MOUNTING CLIP: STEEL
 - FINISH: TERMINAL:-
CONTACT AREA
1. PERFORMANCE LEVEL 1: SELECTIVE GOLD (Au), THICKNESS = 1.1 MICROMETER OVER NICKEL, THICKNESS = 1.25 MICROMETER
2. PERFORMANCE LEVEL 2: SELECTIVE GOLD (Au), THICKNESS = 0.6 MICROMETER OVER NICKEL, THICKNESS = 1.25 MICROMETER
3. PERFORMANCE LEVEL 3: SELECTIVE GOLD (Au), THICKNESS = 0.3 MICROMETER OVER NICKEL, THICKNESS = 1.25 MICROMETER
TERMINATION AREA: SELECTIVE TIN, THICKNESS = 2.5 MICROMETER OVER NICKEL, THICKNESS = 1.25 MICROMETER OVERALL
 - MOUNTING CLIP:-
TIN (Sn), THICKNESS = 5-10 MICROMETER,
OVER NICKEL (Ni), THICKNESS = 2.5 MICROMETER
 - FOR NON MOUNTING CLIP OPTION, CONNECTOR TO BE SECURED WITH RIVETS: 2 TUBULAR RIVETS 2.5 x 0.3 ... DIN 7340
SCREWS: CHEESEHEAD SCREWS M2.5 x DIN 84 AND 2 HEXAGONAL NUTS M 2.5 DIN 934
 - MATERIAL No, BATCH CODE, UL AND CSA MARKING TO BE PRINTED ON CONNECTOR
 - CUT FACE OF TIP WITHOUT PLATING PERMITTED
 - PRODUCT SPECIFICATION : PS-36509-001

RECOMMENDED PCB LAYOUT
COMPONENT SIDE

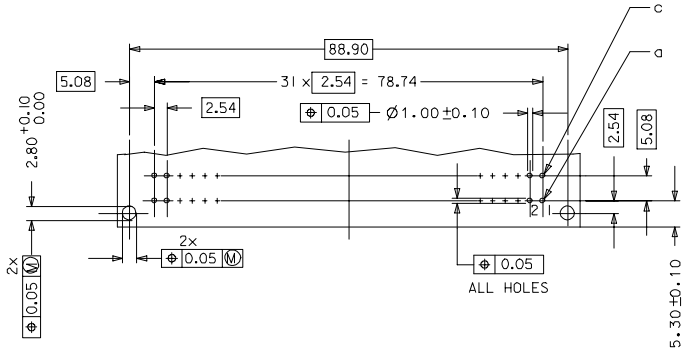

RoHS COMPLIANT

EC No: P007-0044 DRWNGSATTI/MARAD 2006/10/10 CHKDSSUDHIR 2006/10/10 APPR:SSUDHIR 2006/10/10	QUALITY SYMBOLS	GENERAL TOLERANCES (UNLESS SPECIFIED)	DIMENSION STYLE	SCALE	DESIGN UNITS	THIRD ANGLE PROJECTION
	▽=0 ▽=0	[mm] INCH 4 PLACES ± --- ± --- 3 PLACES ± 0.05 ± --- 2 PLACES ± 0.1 ± --- 1 PLACE ± 0.15 ± --- ANGULAR ± 2°	MM ONLY	2:1	METRIC	THIRD ANGLE PROJECTION
D1	DRAFT WHERE APPLICABLE MUST REMAIN WITHIN DIMENSIONS	DRAWN BY: SS CHECKED BY: GJLOWE APPROVED BY: GJLOWE DATE: 1999/10/08	TITLE: ASSEMBLY, DIN41612 R FEMALE, 64 POS A+C LOADED	MATERIAL NO. SD-36509-002	DOCUMENT NO. SD-36509-002	SHEET NO. 1 OF 2
	SIZE: A1	THIS DRAWING CONTAINS INFORMATION THAT IS PROPRIETARY TO MOLEX INCORPORATED AND SHOULD NOT BE USED WITHOUT WRITTEN PERMISSION	MOLEX INCORPORATED			

MATERIAL No	MOLEX ENG No	PERF LEVEL	PLATING	CONTACT SEQUENCE/ROW	MOUNTING CLIP	SEALING STRIP
36509-0025	MM-B2400-R963	1	Au+Ni	1,2,3....32 a+c	NO	NO
36509-0026	MM-B2500-R963	2	Au+Ni	1,2,3....32 a+c	NO	NO
36509-0027	MM-B2600-R963	3	Au+Ni	1,2,3....32 a+c	NO	NO
36509-0031	MM-B2400-R913	1	Au+Ni	1,2,3....32 a+c	YES	NO
36509-0032	MM-B2500-R913	2	Au+Ni	1,2,3....32 a+c	YES	NO
36509-0033	MM-B2600-R913	3	Au+Ni	1,2,3....32 a+c	YES	NO
36509-0037	MM-B2400-R963-101	1	Au+Ni	1,2,3....32 a+c	NO	YES
36509-0038	MM-B2500-R963-101	2	Au+Ni	1,2,3....32 a+c	NO	YES
36509-0039	MM-B2600-R963-101	3	Au+Ni	1,2,3....32 a+c	NO	YES
36509-0043	MM-B2400-R913-101	1	Au+Ni	1,2,3....32 a+c	YES	YES
36509-0044	MM-B2500-R913-101	2	Au+Ni	1,2,3....32 a+c	YES	YES
36509-0045	MM-B2600-R913-101	3	Au+Ni	1,2,3....32 a+c	YES	YES

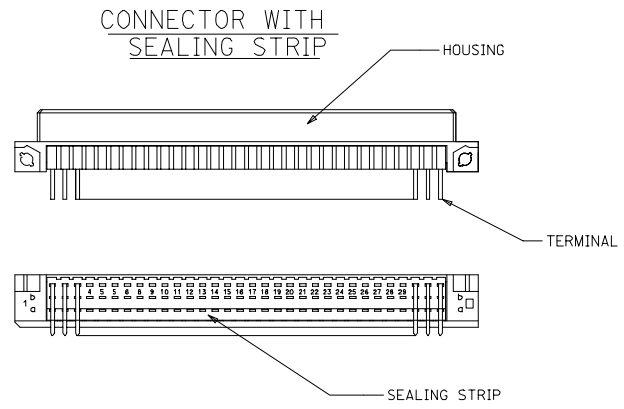

RoHS COMPLIANT

EC No: 2007/0044 DRINGSATTI/MARAD 2006/10/10 CHIKKOSUDHAR 2006/10/11 APPR/SSUDHAR 2006/10/16	QUALITY SYMBOLS	GENERAL TOLERANCES (UNLESS SPECIFIED)	DIMENSION STYLE	SCALE	DESIGN UNITS	THIRD ANGLE PROJECTION															
	$\nabla=0$ $\nabla=0$	<table border="1"> <thead> <tr> <th></th> <th>mm</th> <th>INCH</th> </tr> </thead> <tbody> <tr> <td>4 PLACES</td> <td>± 0.15</td> <td>± 0.005</td> </tr> <tr> <td>3 PLACES</td> <td>± 0.05</td> <td>± 0.002</td> </tr> <tr> <td>2 PLACES</td> <td>± 0.1</td> <td>± 0.004</td> </tr> <tr> <td>1 PLACE</td> <td>± 0.15</td> <td>± 0.006</td> </tr> </tbody> </table>		mm	INCH	4 PLACES	± 0.15	± 0.005	3 PLACES	± 0.05	± 0.002	2 PLACES	± 0.1	± 0.004	1 PLACE	± 0.15	± 0.006	MM ONLY	2:1	METRIC	
		mm	INCH																		
	4 PLACES	± 0.15	± 0.005																		
3 PLACES	± 0.05	± 0.002																			
2 PLACES	± 0.1	± 0.004																			
1 PLACE	± 0.15	± 0.006																			
DESCRIPTION	DRAFT WHERE APPLICABLE MUST REMAIN WITHIN DIMENSIONS	SEE CHART	DRAWN BY: SS CHECKED BY: G.J.LOWE APPROVED BY: G.J.LOWE DATE: 1999/09/24	TITLE: ASSEMBLY, DIN41612 R FEMALE, 64 POS A+C LOADED MATERIAL NO: SD-36509-002 DOCUMENT NO: SD-36509-002 SHEET NO: 2 OF 2																	
REV	THIS DRAWING CONTAINS INFORMATION THAT IS PROPRIETARY TO MOLEX INCORPORATED AND SHOULD NOT BE USED WITHOUT WRITTEN PERMISSION																				