

PART NO.	ENG. NO.
02-09-1142	1433-A(P90)I
02-09-1144	1433-A(P90)IL
02-09-5146	1433-A(P550)
02-09-5147	1433-A(P550)L
02-09-5165	1433-A(P563)

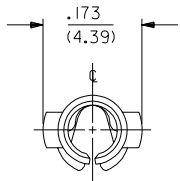
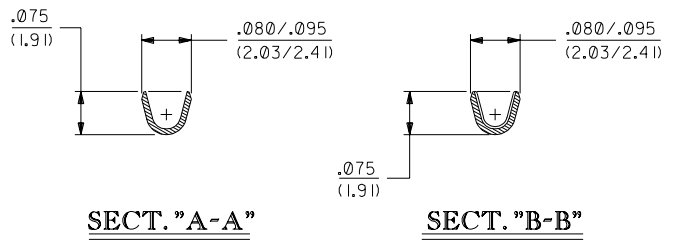

SECT. "A-A"

SECT. "B-B"

LEGEND

1433-A(****)*
 * - FORM
 * - BLANK=CHAIN
 * - L=LOOSE
 P=PREPLATE
 BLANK=POSTPLATE
 FINISH CODE

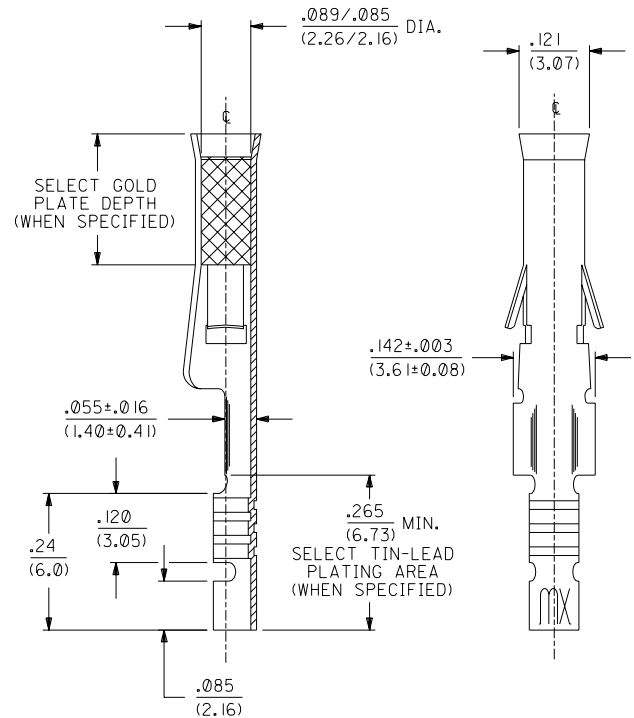
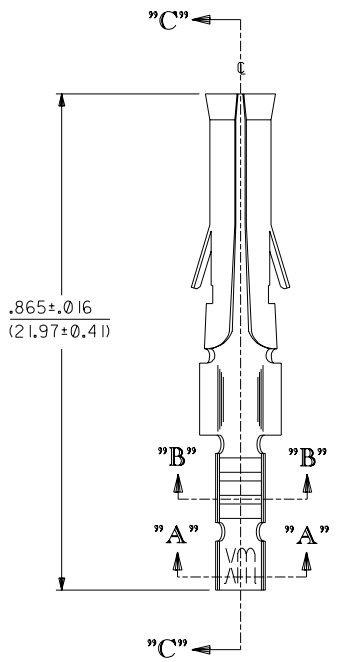

SECT. "C-C"

- NOTES:
1. TERMINAL FOR USE WITH .093/(2.36) SERIES HOUSINGS AND WILL ACCEPT 24 THRU 30 AWG WIRE.
 2. INSERTION FORCE: 3.5 LBS. MAX. WHEN TERMINAL IS INSERTED INTO AN .093 SERIES HOUSING.
 3. CONTACT RETENTION: 20 LBS. MIN.
 4. THIS PART CONFORMS TO PROD. SPEC. 02-09.

- FINISH CODES:
- 901 HOT TIN DIP .000020/(0.00051) MIN.
 - 903 HOT TIN-LEAD DIP .000050/(0.00127) MIN.
 - 550 SELECT GOLD PLATE .000015/(0.00038) MIN. IN CONTACT AREA, OVER .000030/(0.00076) MIN. NICKEL OVERALL WITH .000010/(0.00025) MAX. GOLD FLASH OVERALL.
 - 563 SELECT GOLD PLATE .000030/(0.00076) MIN. IN CONTACT AREA, SELECT TIN-LEAD PLATING .000100/(0.00254) MIN. IN CRIMP AREA OVER .000050/(0.00127) NICKEL OVERALL.

MATERIAL:
 CARTRIDGE BRASS, ALLOY *C26000,
 .010/(0.25) THICK, SPRING TEMPER

AA	REVISE PER ECR 05 0799 GC 2/13/95 RW
Z	FINAL RELEASE ECR 01 0454 GC 2/20/91 RW

DIMENSIONS SHOWN (METRIC) INCH UNLESS OTHERWISE SPECIFIED TOLERANCES: ANGULAR ± 1/2°		MFG. SH. REV. LTR. REVISIONS	
3 PLACE ± .010 --- METRIC		REVISIONS	
2 PLACE ± .014 ± 0.25		TITLE	
1 PLACE --- ± 0.36		CRIMP TERMINAL, FEMALE .093/(2.36) DIA. FOR 24 THRU 30 AWG WIRE	
DRAFT WHERE APPLICABLE MUST REMAIN WITHIN DIMENSIONS		MOLEX INCORPORATED SHEET NO. DATE U.S.A. 1 2/20/91	
DRWG. BY GC CHK'D. BY RW		PART NO. DRWG. NO.	
APPR'D. BY GWF SCALE 6 : 1		SEE CHART SD-1433-*	
FILE NAME S1433X1.DGN		THIS DRAWING CONTAINS INFORMATION THAT IS PROPRIETARY TO MOLEX INC. AND SHOULD NOT BE USED WITHOUT WRITTEN PERMISSION	