

THIS DRAWING IS UNPUBLISHED. RELEASED FOR PUBLICATION
 © COPYRIGHT BY TYCO ELECTRONICS CORPORATION. ALL INTERNATIONAL RIGHTS RESERVED.

LOC	DIST	REVISIONS			
P	LTR	DESCRIPTION	DATE	DWN	APVD
—	—	F	REVISED PER ECO-09-010589	5/1/09	SS MS

- 1. MATERIAL: .0157 THK BRASS.
- 2. COPPER FLASH .000100 MIN OVER BRASS PART.
- 3. TIN PLATING .000080 MIN THK

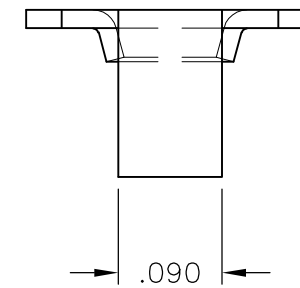
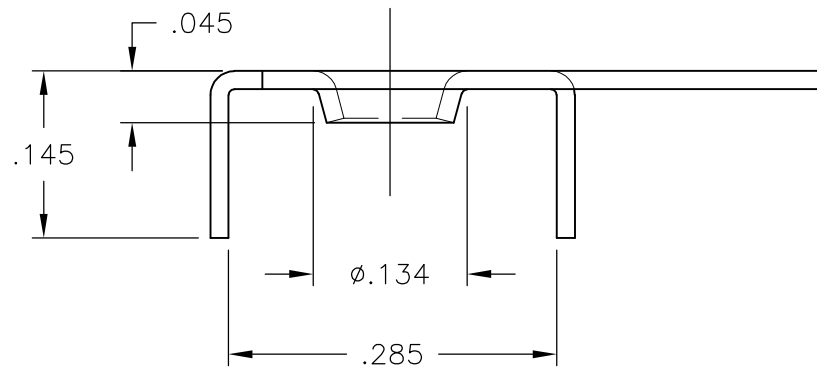
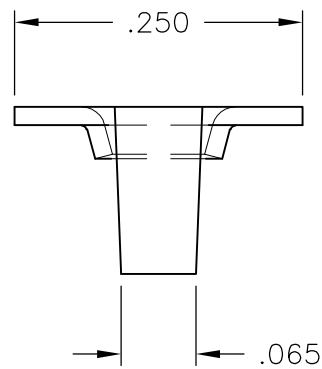
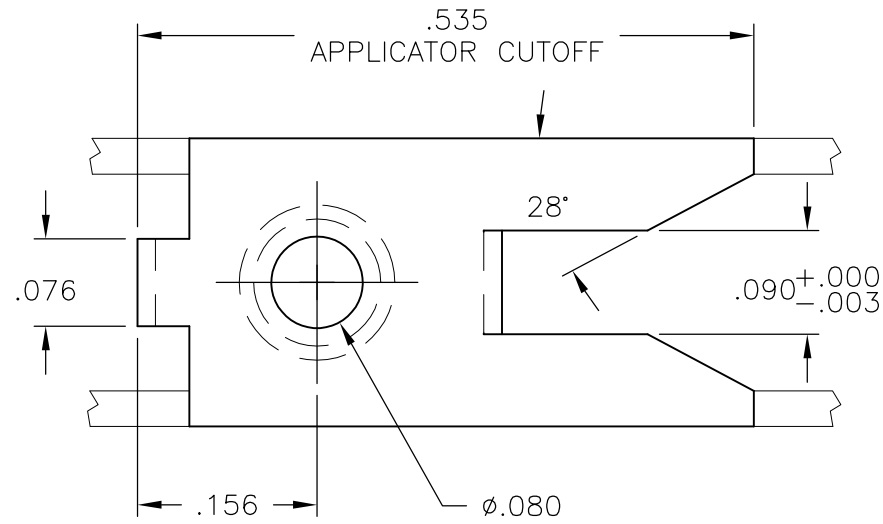

61480-2

PART NUMBER

THIS DRAWING IS A CONTROLLED DOCUMENT.		DWN S SCHLEGEL 09APR2009	Tyco Electronics Corporation Harrisburg, PA 17105-3608		
DIMENSIONS: INCHES		CHK M STRECKEWALD 4/9/09	NAME PHASING LINE CLIP		
TOLERANCES UNLESS OTHERWISE SPECIFIED:		APVD M STRECKEWALD 4/9/09	PRODUCT SPEC —		
0 PLC ± - 1 PLC ± - 2 PLC ± .02 3 PLC ± .010 4 PLC ± - ANGLES ± 2°		APPLICATION SPEC —	SIZE A3	CAGE CODE 00779	DRAWING NO C-61480
MATERIAL — 1		WEIGHT —	RESTRICTED TO —		SCALE 6:1
CUSTOMER DRAWING			SHEET 1 OF 2	REV F	

THIS DRAWING IS UNPUBLISHED. RELEASED FOR PUBLICATION
 © COPYRIGHT BY TYCO ELECTRONICS CORPORATION. ALL INTERNATIONAL RIGHTS RESERVED.

LOC	DIST	REVISIONS					
		P	LTR	DESCRIPTION	DATE	DWN	APVD
-	-	-	-	SEE SHEET 1	-	-	-

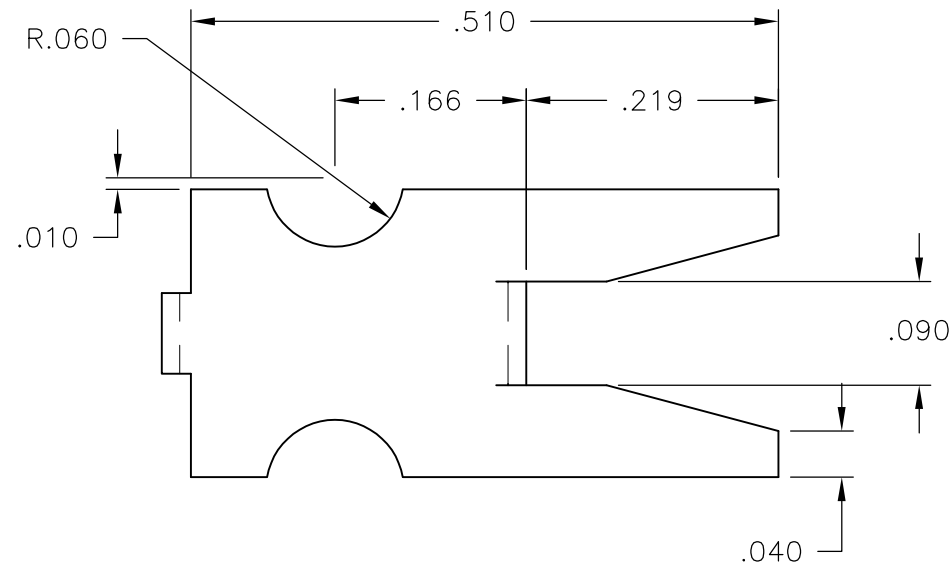

SUPERSEDED BY
1986550-1

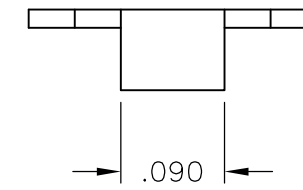
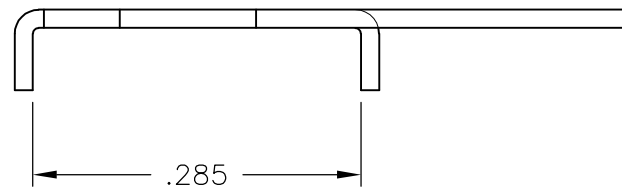
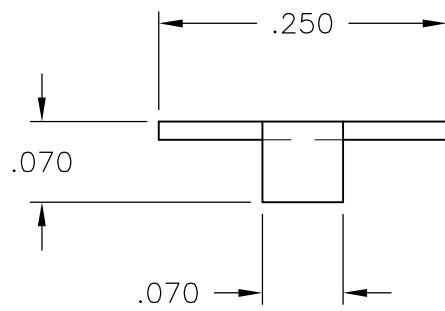

4 SUPERCEDED BY 1986550-1	61480-3
PART NUMBER	

THIS DRAWING IS A CONTROLLED DOCUMENT.		DWN S SCHLEGEL 09APR2009	Tyco Electronics Corporation Harrisburg, PA 17105-3608	
DIMENSIONS: INCHES 		CHK M STRECKEWALD 4/9/09		
TOLERANCES UNLESS OTHERWISE SPECIFIED: 0 PLC ± - 1 PLC ± - 2 PLC ± .02 3 PLC ± .010 4 PLC ± - ANGLES ± 2°		APVD M STRECKEWALD 4/9/09	NAME PHASING LINE CLIP	
MATERIAL -		FINISH -	PRODUCT SPEC -	APPLICATION SPEC -
-		WEIGHT -	SIZE A3	CAGE CODE 00779
-		DRAWING NO C-61480		RESTRICTED TO -
-		CUSTOMER DRAWING		SCALE 6:1
-		SHEET 2 OF 2		REV F