

12	11	10	9
MAT'L NO.	ENG NO.	FINISH	CARRIER
190220006	AMCT-17	ZINC CHROMATE PLATING	LOOSE PIECE
190220009	AMCT-17T		TAPE MOUNTED

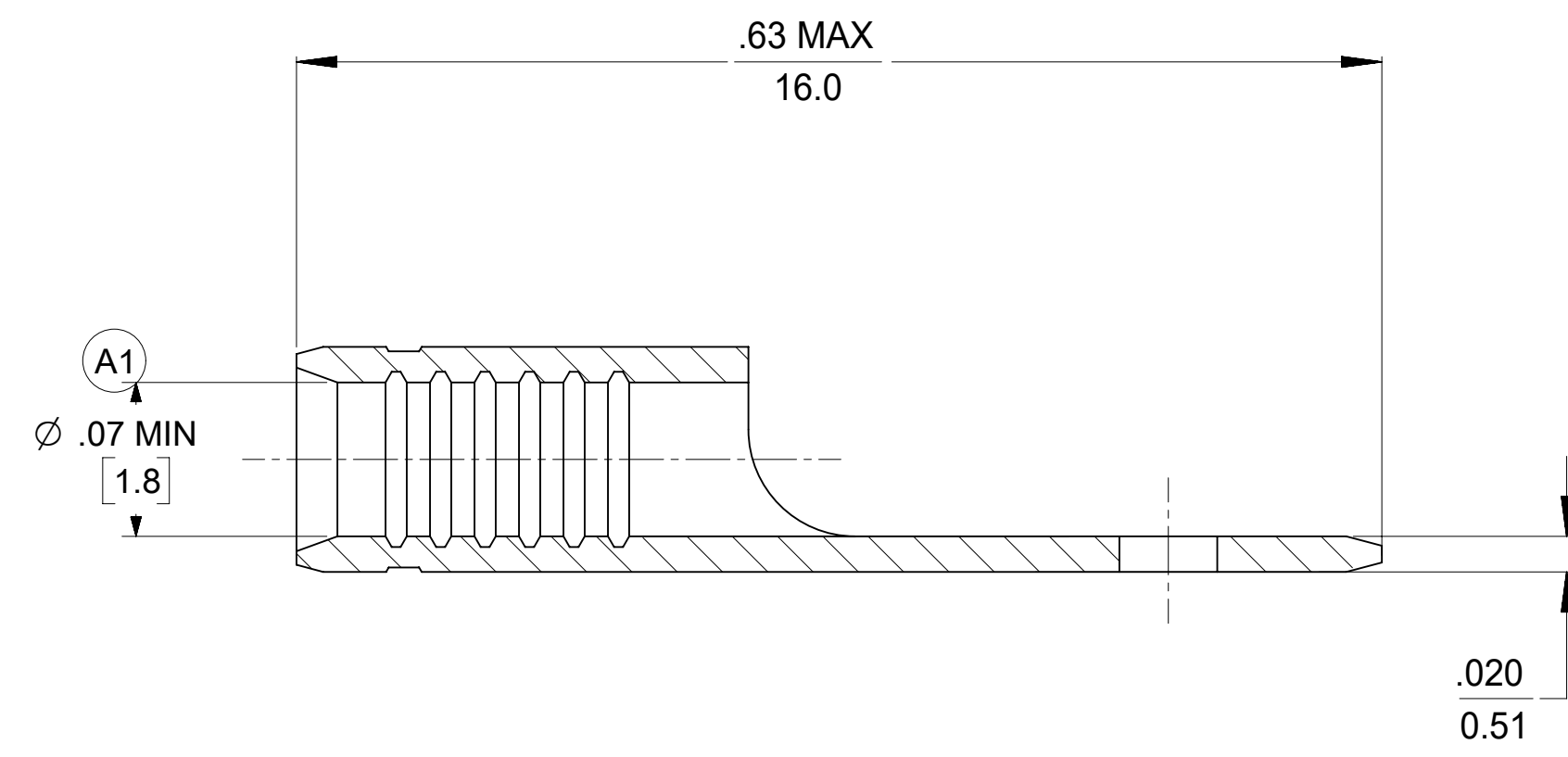
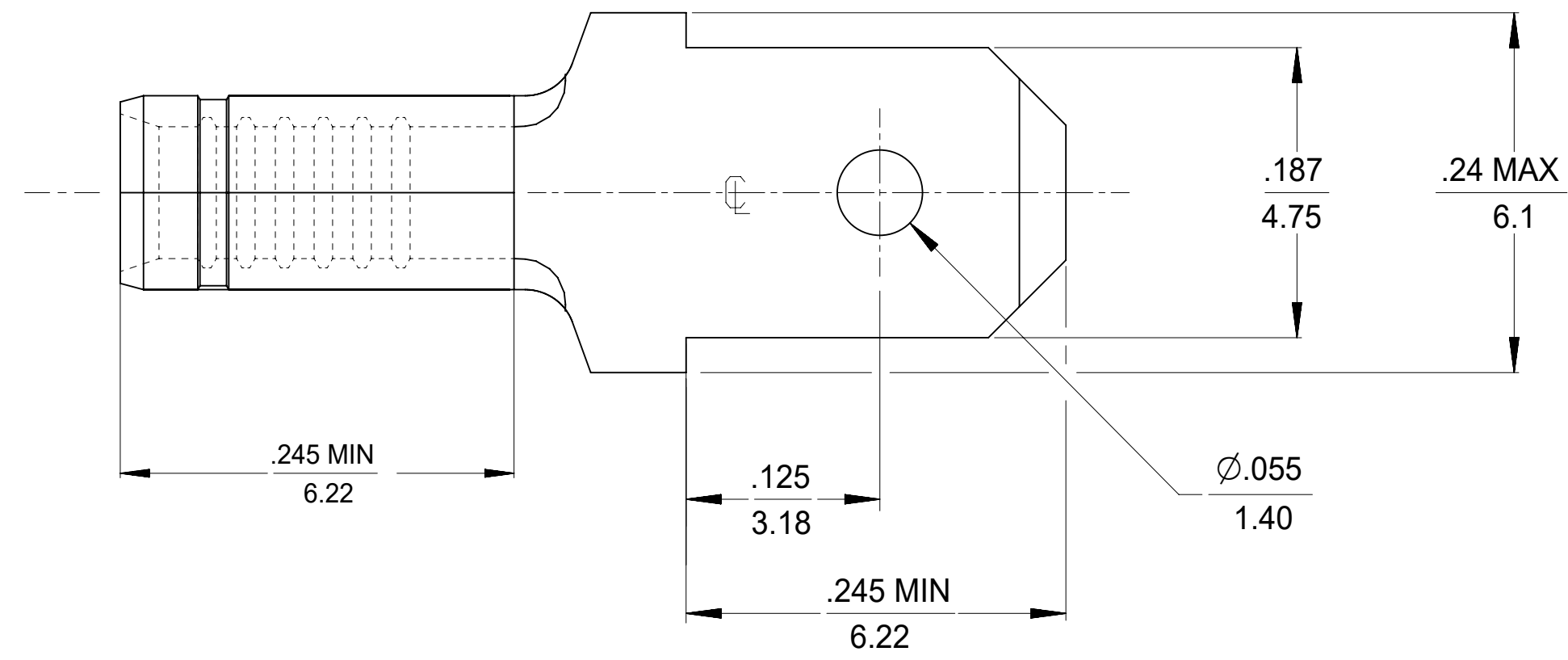
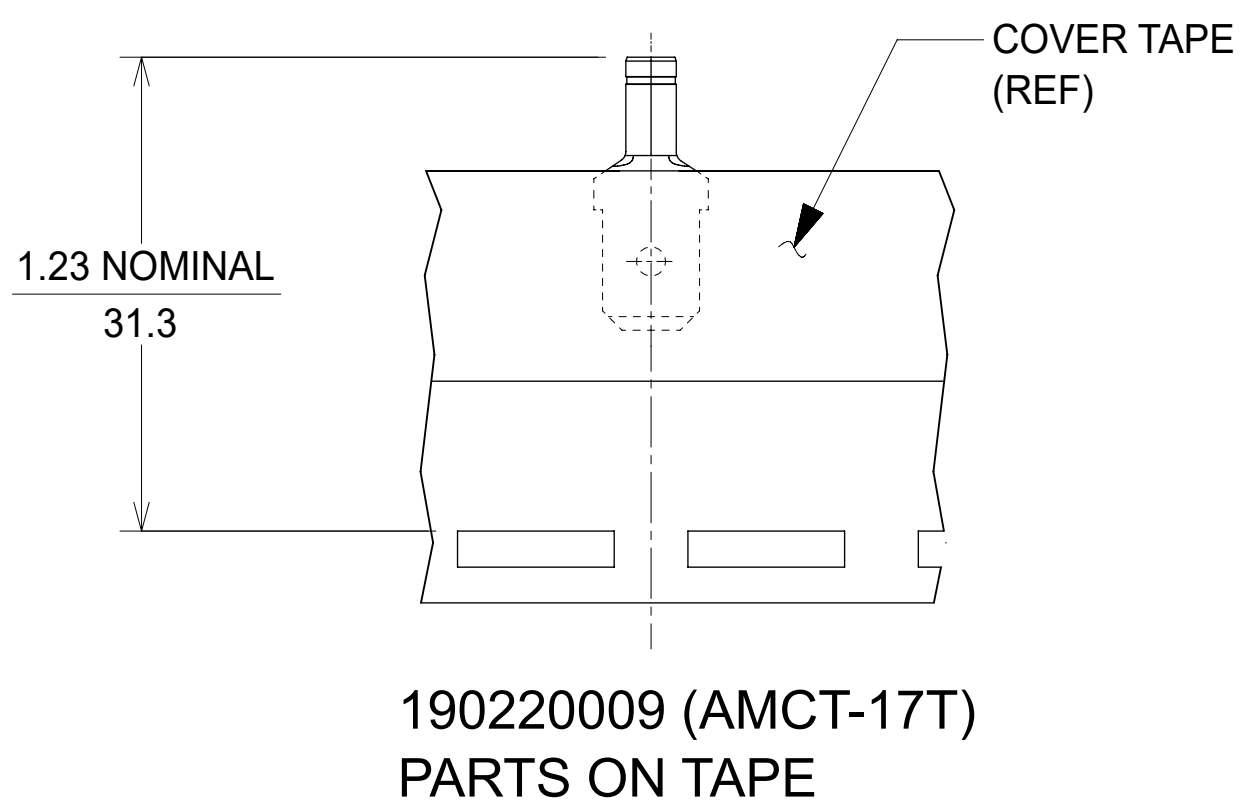

- NOTE(S):
1. MATERIAL: BRASS
 2. FINISH: SEE CHART
 3. WIRE SIZE: 22-18 AWG (0.38-0.96 MM²)
 4. TAB DIMENSIONS CONFORM TO UL310 SPECIFICATIONS.
 5. PART IS RoHS COMPLIANT.

FUNCTIONAL SYMBOLS	THIS DRAWING CONTAINS INFORMATION THAT IS PROPRIETARY TO MOLEX ELECTRONIC TECHNOLOGIES, LLC AND SHOULD NOT BE USED WITHOUT WRITTEN PERMISSION												
	DIMENSION UNITS	SCALE		CURRENT REV DESC: BARREL ID .07 MIN WAS .08 MIN						molex			
FA = 0	IN/MM	10:1		EC NO: 676456 DRWN: DMYRICK 2021/09/02 CHK'D: EJOHNSON04 2021/09/10 APPR: EJOHNSON04 2021/09/10									
FC = 0	GENERAL TOLERANCES (UNLESS SPECIFIED)												
DIVISIONAL SYMBOLS	4 PLACES	±	MM	±	INCH	INITIAL REVISION: DRWN: EHILE 2008/01/28 APPR: JMACNEIL 2008/02/13							
	3 PLACES	±		±	0.005								
	2 PLACES	±	0.13	±	0.01								
	1 PLACE	±	0.25	±									
	0 PLACES	±		±									
	ANGULAR TOL	±		±	°	THIRD ANGLE PROJECTION		DRAWING	SERIES	DOCUMENT NUMBER	DOC TYPE	DOC PART	REVISION
DRAFT WHERE APPLICABLE MUST REMAIN WITHIN DIMENSIONS				C-SIZE		19022		SD-19022-017		PSD	001	A1	
MATERIAL NUMBER				CUSTOMER		SHEET NUMBER		SEE CHART		GENERAL MARKET		1 OF 1	