

THIS DRAWING IS UNPUBLISHED. RELEASED FOR PUBLICATION
 © COPYRIGHT - By - ALL RIGHTS RESERVED.

LOC	DIST	REVISIONS			
P	LTR	DESCRIPTION	DATE	DWN	APVD
AF	50				
	G	REVISED PER ECR-12-013219	08JAN13	KH	KR
	G1	REVISED PER ECR-19-018127	10AUG20	AA	EW

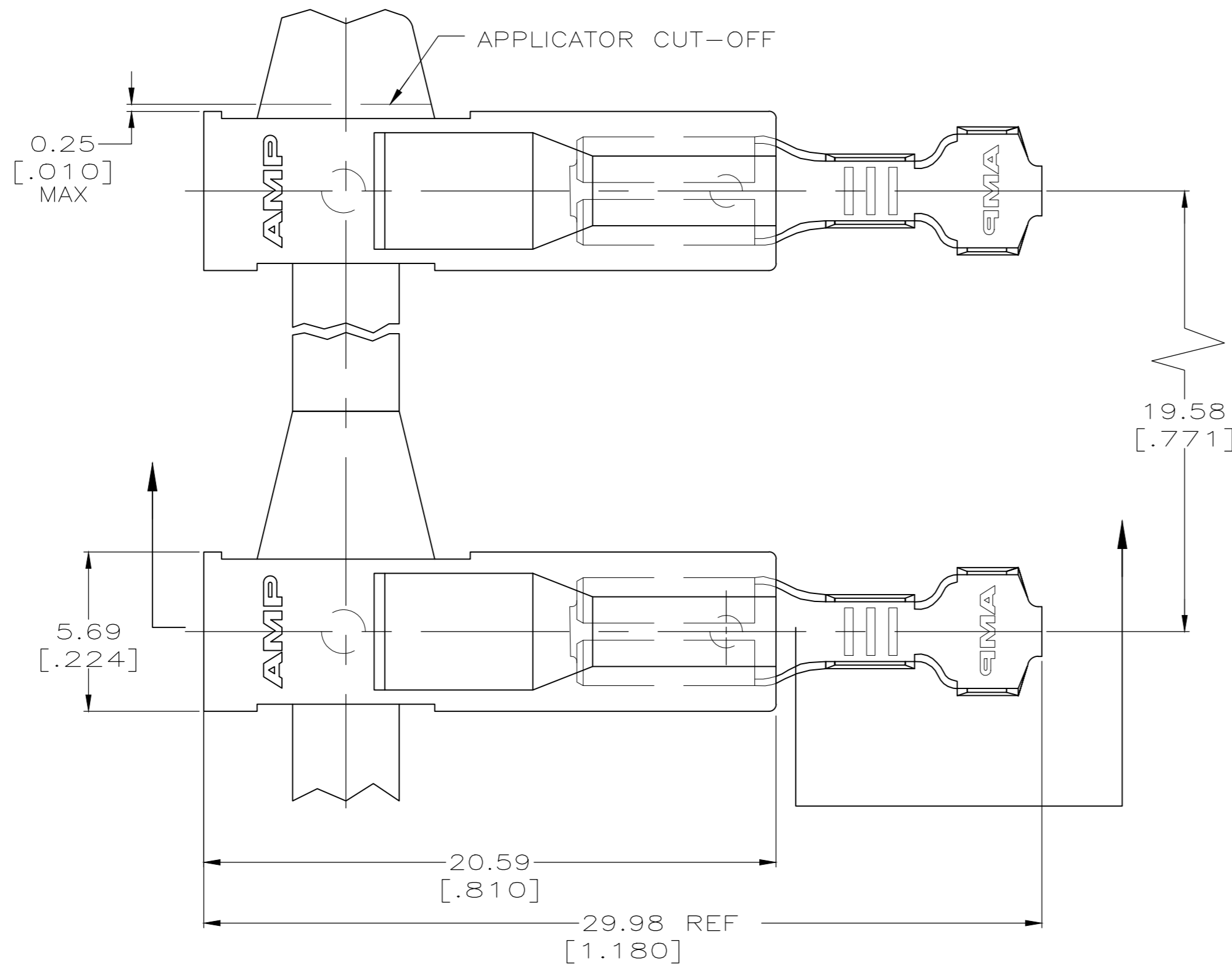

- 1 MATING TAB THK IS 0.81±0.025[.032±.001]
- 2 WIRE SIZE IS [#22-#18] AWG.
- 3 INSULATION RANGE IS 2.03-3.05[.080-.120] DIA.
- △ PREPRODUCTION - FASR REQ

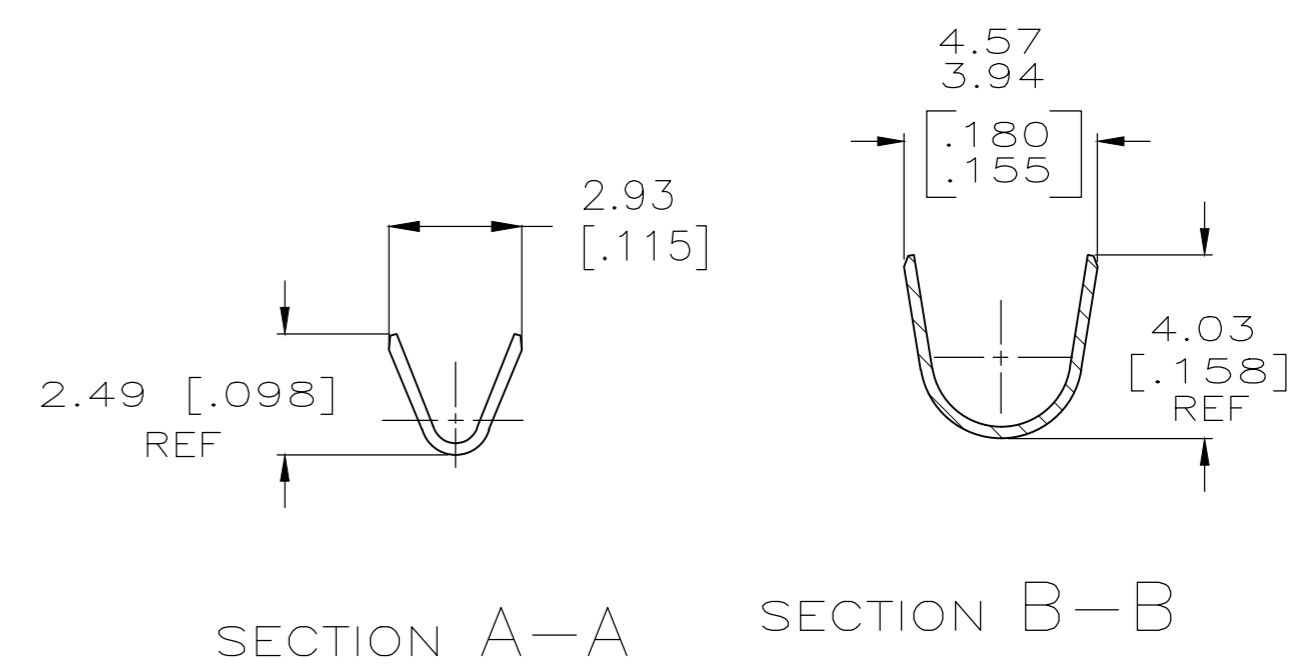
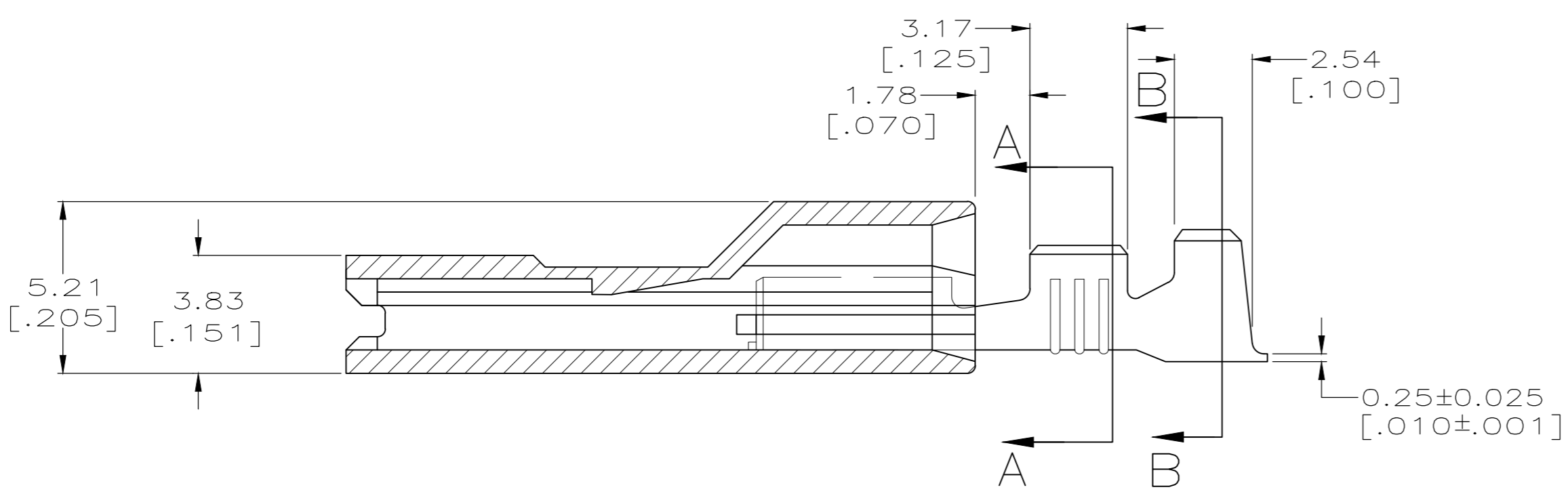

OBSOLETE	0.002032 [.000080] MIN TIN	521436-2
	-	△ 521436-1
TERMINAL FINISH		PART NO.

THIS DRAWING IS A CONTROLLED DOCUMENT.		DWN	JR RUTH	22OCT01	 TE Connectivity
DIMENSIONS: mm [INCHES]		CHK	J HUMMEL	22OCT01	
TOLERANCES UNLESS OTHERWISE SPECIFIED:		APVD	J HUMMEL	22OCT01	
0 PLC ± - 1 PLC ± - 2 PLC ± 0.25 [.010] 3 PLC ± - 4 PLC ± - ANGLES ± -		PRODUCT SPEC	108-1285		
MATERIAL		APPLICATION SPEC	114-2124		NAME
TERMINAL - BRASS		FINISH	-		ASSEMBLY, RECEPTACLE, ULTRA-POD, 2.79 [.110] SERIES
HSG - 6/6 NYLON, V2		TERMINAL - SEE TABLE	-		SIZE
		HOUSING - NATURAL	-		CAGE CODE
			-		DRAWING NO
			-		RESTRICTED TO
			-		SCALE
			-		SHEET
			-		REV
			-		G1