

PART NUMBER DATA									
CIRCUITS	A IN	mm	B IN	mm	C IN	mm	D IN	mm	
2	1.58	40.2	.375	9.52	1.125	28.58	.83	21.1	
3	1.96	49.7	.750	19.05	1.500	38.10	1.21	30.7	
4	2.33	59.2	1.125	28.58	1.875	47.63	1.58	40.2	
5	2.71	68.7	1.500	38.10	2.250	57.15	1.96	49.7	
6	3.08	78.3	1.875	47.63	2.625	66.68	2.33	59.2	
7	3.46	87.8	2.250	57.15	3.000	76.20	2.71	68.8	
8	3.83	97.3	2.625	66.68	3.375	85.73	3.08	78.3	
9	4.21	106.8	3.000	76.20	3.750	95.25	3.46	87.8	
10	4.58	116.4	3.375	85.73	4.125	104.78	3.83	97.3	
11	4.96	125.9	3.750	95.25	4.500	114.30	4.21	106.9	
12	5.33	135.4	4.125	104.78	4.875	123.83	4.58	116.4	
13	5.71	144.9	4.500	114.30	5.250	133.35	4.96	125.9	
14	6.08	154.5	4.875	123.83	5.625	142.88	5.33	135.4	
15	6.46	164.0	5.250	133.35	6.000	152.40	5.71	145.0	
16	6.83	173.5	5.625	142.88	6.375	161.93	6.08	154.5	
17	7.21	183.0	6.000	152.40	6.750	171.45	6.46	164.0	
18	7.58	192.6	6.375	161.93	7.125	180.98	6.83	173.5	
19	7.96	202.1	6.750	171.45	7.500	190.50	7.21	183.1	
20	8.33	211.6	7.125	180.98	7.875	200.03	7.58	192.6	
21	8.71	221.1	7.500	190.50	8.250	209.55	7.96	202.1	
22	9.08	230.7	7.875	200.03	8.625	219.08	8.33	211.6	
23	9.46	240.2	8.250	209.55	9.000	228.60	8.71	221.2	
24	9.83	249.7	8.625	219.08	9.375	238.13	9.08	230.7	
25	10.21	259.2	9.000	228.60	9.750	247.65	9.46	240.2	
26	10.58	268.8	9.375	238.13	10.125	257.18	9.83	249.7	

PART NUMBER LEGEND

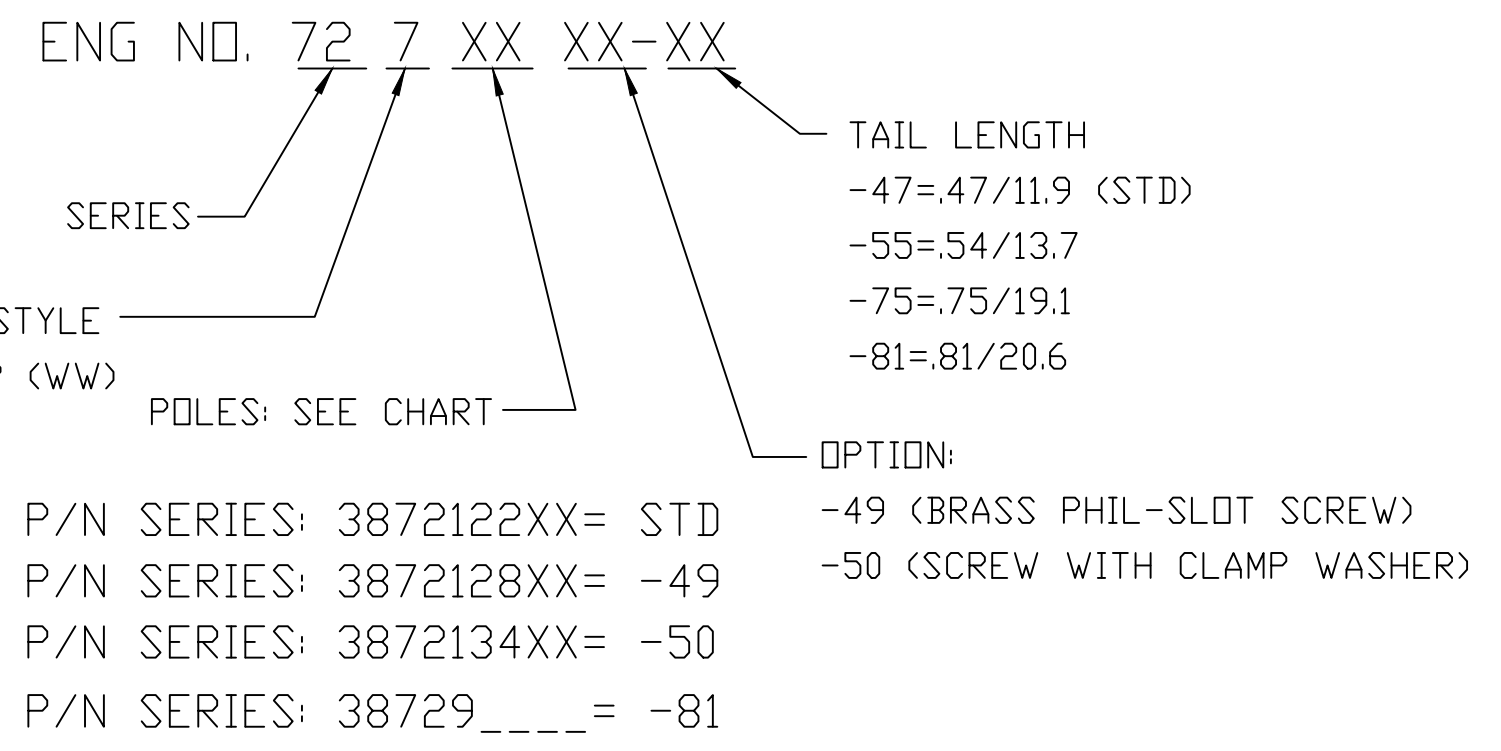

- NOTES:
- MATERIAL: SEE TABLE
  - ASSEMBLY MUST MEET BEAU WORKMANSHIP STANDARD ES-19900-059
  - PRODUCT SPECIFICATION: PS-38710-001
  - SEE SAP BOM FOR COMPONENT PART NUMBERS
  - "XX" REFERS TO THE QUANTITY OF CIRCUITS

REF. THIS DRAWING SUPERSEDES E-78721-003 REV-B

ITEM	QTY	DESCRIPTION	MATERIAL NO.	ENGINEERING NO.
6	XX	#6-32 PH/SLOTTED SCREW (OPTION -50)	380010099	2504-9201-C220
5	XX	#6-32 PH/SLOTTED SCREW (OPTION -49)	380010058	1804-9101-A120
4	XX	#6-32 PH/SLOTTED SCREW (STD)	380010092	2504-9101-C220
3	2	MOUNTING PLATE	380021308	7204-7201-A120
2	XX	TERMINAL	380021279	7204-3411-A260
1	1	BARRIER TERMINAL STRIP	38728_	7200-XX02-V000

RELEASED  
EC NO: ICG2015-0118  
DRWN: RSTONE 2014/07/18  
CHKD: BARDEN 2014/07/23  
APPR: JFMURPHY 2014/08/02

DESCRIPTION  
A

QUALITY SYMBOL  
▽=0  
▽C=0

GENERAL TOLERANCES (UNLESS SPECIFIED)

	mm	INCH
4 PLACES	±---	±---
3 PLACES	±---	±.005
2 PLACES	±0.13	±.01
1 PLACE	±0.3	±---

ANGULAR ±---°

DRAFT WHERE APPLICABLE MUST REMAIN WITHIN DIMENSIONS

DIMENSION STYLE IN/MM

SCALE ---

DESIGN UNITS INCH

THIRD ANGLE PROJECTION

DRAWN BY RSTONE DATE 2014/07/18

CHECKED BY DATE

APPROVED BY JFMURPHY DATE 2014/08/02

MATERIAL NO. SEE PART LEGEND

DOCUMENT NO. E-38721-010

SHEET NO. 1 OF 1

THIS DRAWING CONTAINS INFORMATION THAT IS PROPRIETARY TO MOLEX INCORPORATED AND SHOULD NOT BE USED WITHOUT WRITTEN PERMISSION

ISO VIEW  
4 CIRCUIT SHOWN

PART NUMBER DATA

CIRCUITS	A IN		B IN		C IN		D IN	
	mm	mm	mm	mm	mm	mm	mm	
2	1.58	40.2	.375	9.52	1.125	28.58	.83	21.1
3	1.96	49.7	.750	19.05	1.500	38.10	1.21	30.7
4	2.33	59.2	1.125	28.58	1.875	47.63	1.58	40.2
5	2.71	68.7	1.500	38.10	2.250	57.15	1.96	49.7
6	3.08	78.3	1.875	47.63	2.625	66.68	2.33	59.2
7	3.46	87.8	2.250	57.15	3.000	76.20	2.71	68.8
8	3.83	97.3	2.625	66.68	3.375	85.73	3.08	78.3
9	4.21	106.8	3.000	76.20	3.750	95.25	3.46	87.8
10	4.58	116.4	3.375	85.73	4.125	104.78	3.83	97.3
11	4.96	125.9	3.750	95.25	4.500	114.30	4.21	106.9
12	5.33	135.4	4.125	104.78	4.875	123.83	4.58	116.4
13	5.71	144.9	4.500	114.30	5.250	133.35	4.96	125.9
14	6.08	154.5	4.875	123.83	5.625	142.88	5.33	135.4
15	6.46	164.0	5.250	133.35	6.000	152.40	5.71	145.0
16	6.83	173.5	5.625	142.88	6.375	161.93	6.08	154.5
17	7.21	183.0	6.000	152.40	6.750	171.45	6.46	164.0
18	7.58	192.6	6.375	161.93	7.125	180.98	6.83	173.5
19	7.96	202.1	6.750	171.45	7.500	190.50	7.21	183.1
20	8.33	211.6	7.125	180.98	7.875	200.03	7.58	192.6
21	8.71	221.1	7.500	190.50	8.250	209.55	7.96	202.1
22	9.08	230.7	7.875	200.03	8.625	219.08	8.33	211.6
23	9.46	240.2	8.250	209.55	9.000	228.60	8.71	221.2
24	9.83	249.7	8.625	219.08	9.375	238.13	9.08	230.7
25	10.21	259.2	9.000	228.60	9.750	247.65	9.46	240.2
26	10.58	268.8	9.375	238.13	10.125	257.18	9.83	249.7

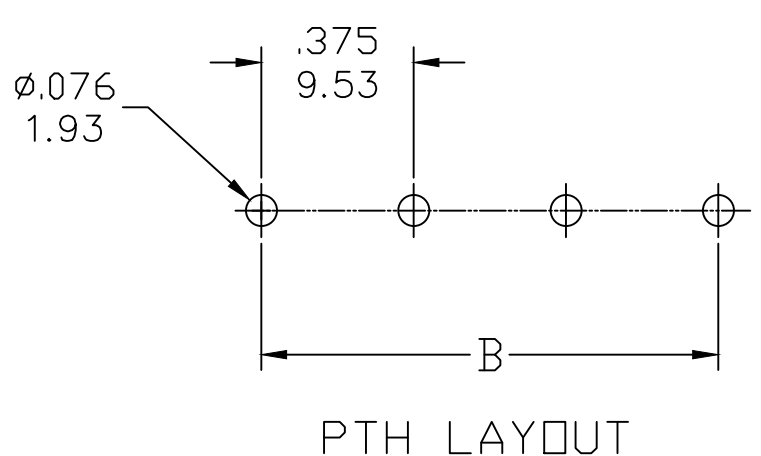
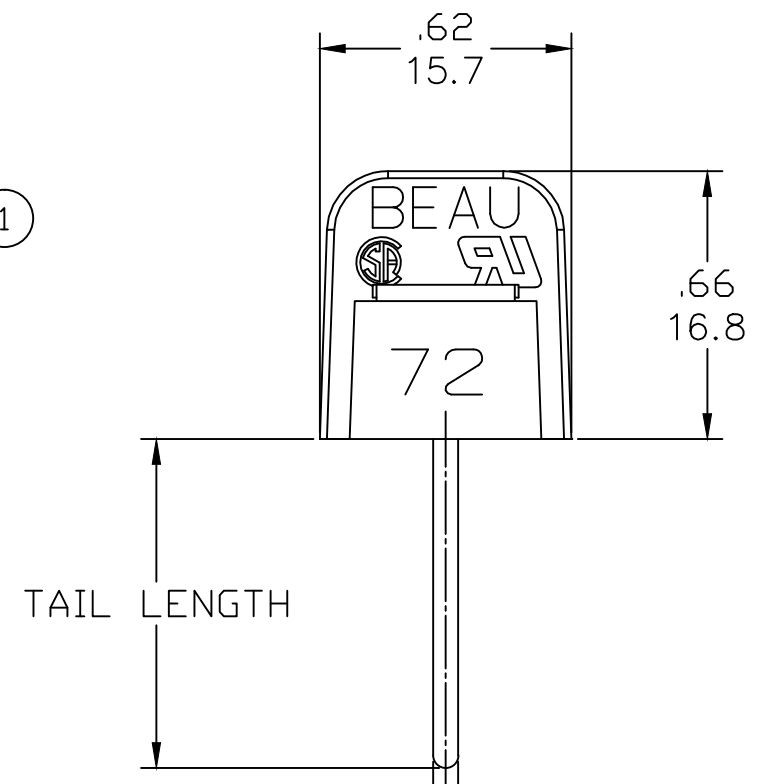
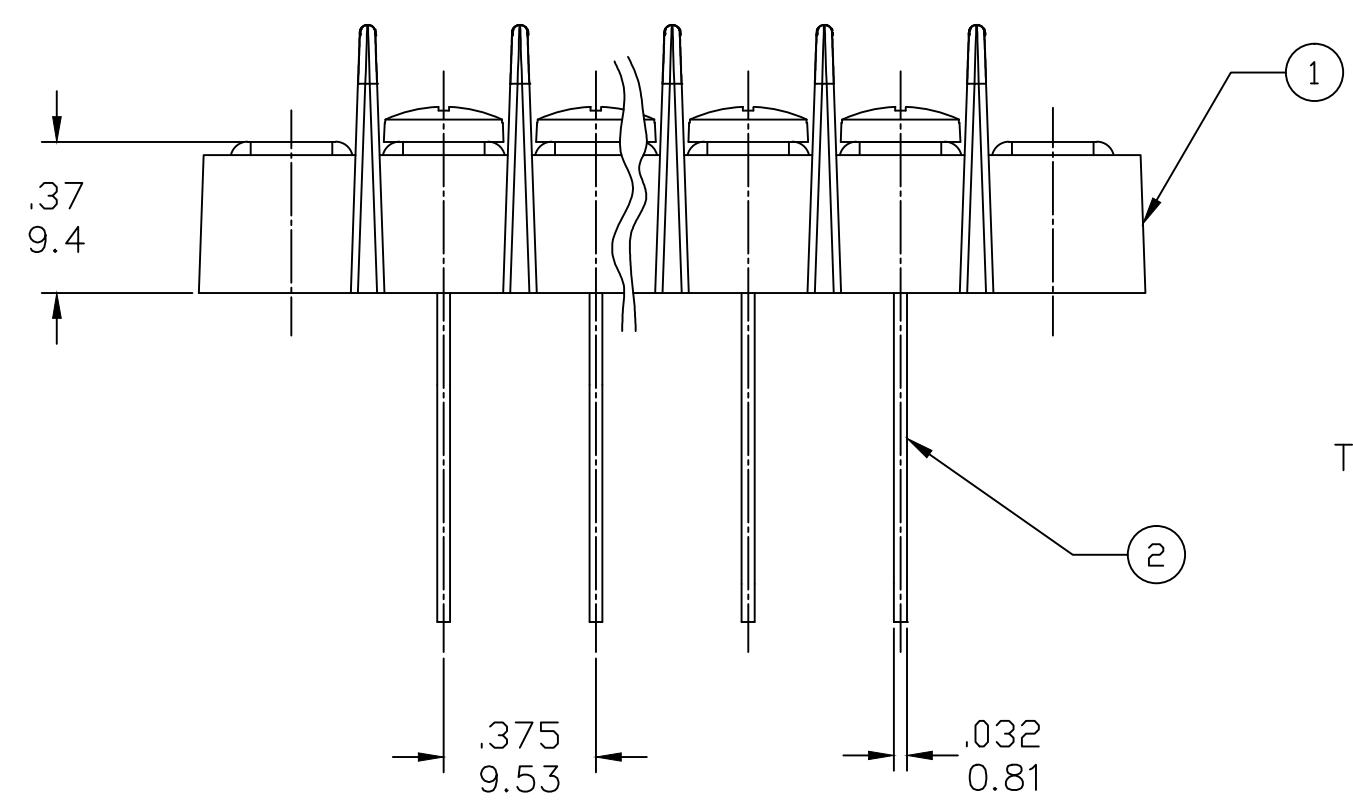
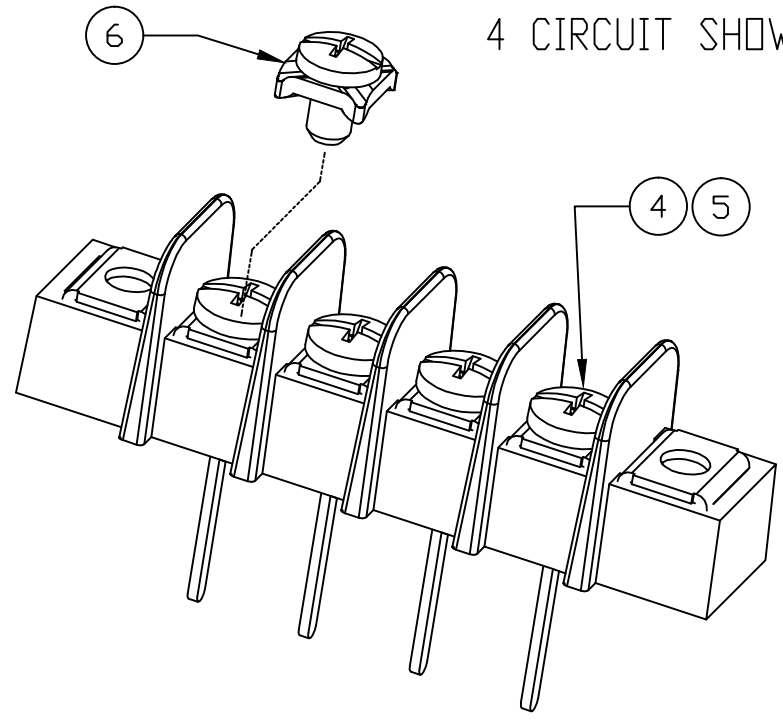
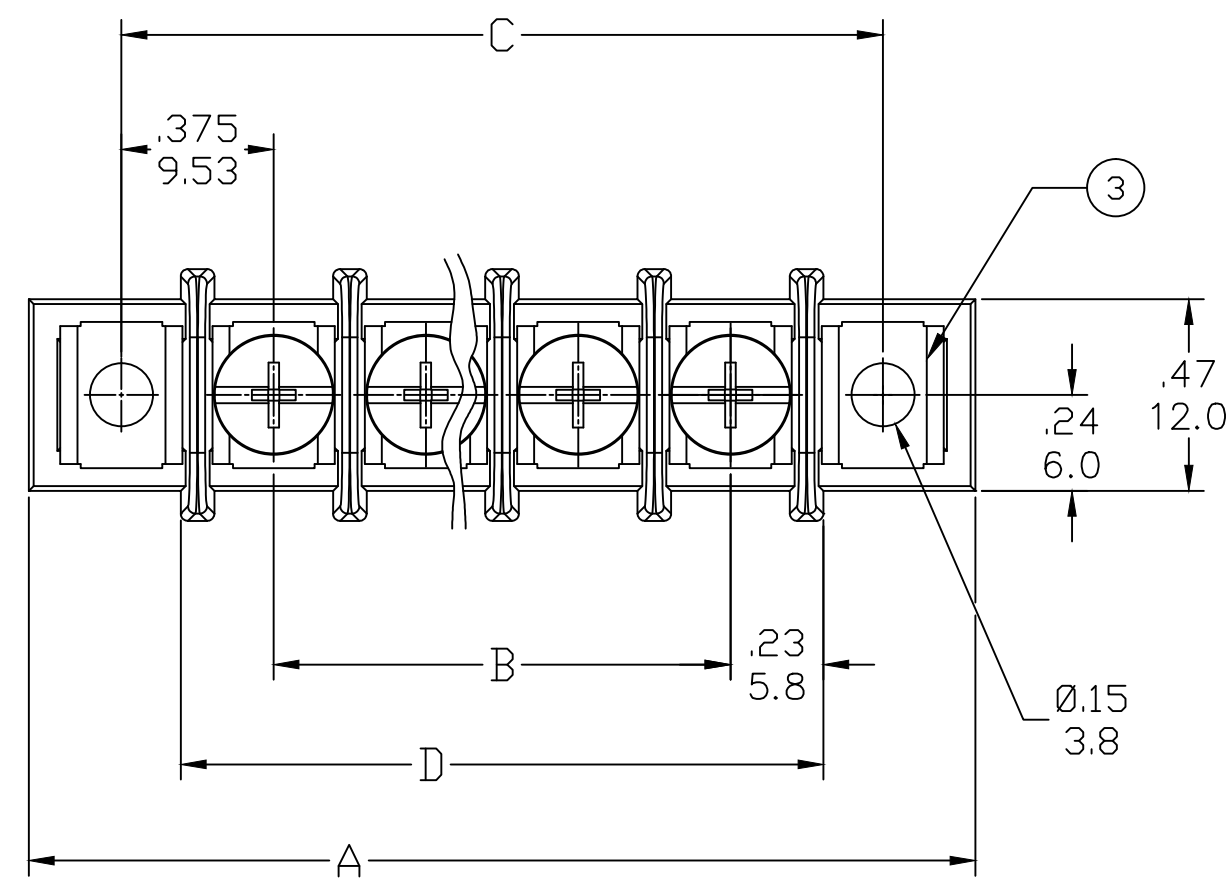

PART NUMBER LEGEND

ENG NO. 72 7 XX XX-XX

SERIES: 72, 7, XX, XX-XX  
 TAIL LENGTH:  
 -47=.47/11.9 (STD)  
 -55=.54/13.7  
 -75=.75/19.1  
 -81=.81/20.6  
 OPTION:  
 -49 (BRASS PHIL-SLOT SCREW)  
 -50 (SCREW WITH CLAMP WASHER)  
 SAP P/N SERIES: 3872122XX= STD  
 SAP P/N SERIES: 3872128XX= -49  
 SAP P/N SERIES: 3872134XX= -50  
 SAP P/N SERIES: 38729\_\_\_ = -81

- NOTES:
1. MATERIAL: SEE TABLE
  2. FINISHES: SEE TABLE
  3. PRODUCT SPECIFICATION: PS-38710-001
  4. "XX" REFERS TO THE QUANTITY OF CIRCUITS
  5. DIMS SHOWN ARE FOR REFERENCE ONLY

REF. THIS DRAWING SUPERSEDES SD-78721-003 REV-B

ITEM	QTY	DESCRIPTION	MATERIAL	FINISH
6	XX	#6-32 PH/SLOTTED SCREW (OPTION -50)	STEEL	ZN, CLEAR CHROMATE
5	XX	#6-32 PH/SLOTTED SCREW (OPTION -49)	BRASS	NICKEL PLATE
4	XX	#6-32 PH/SLOTTED SCREW (STD)	STEEL	ZN, CLEAR CHROMATE
3	2	MOUNTING PLATE	BRASS	NICKEL PLATE
2	XX	TERMINAL	BRASS	TIN PLATE
1	1	BARRIER TERMINAL STRIP	PBT	BLACK

RELEASED	EC NO: ICG2015-0118	DRWN: RSTONE 2014/07/17	CHKD: BARDEN 2014/07/23	APPR: JFMURPHY 2014/08/02	DESCRIPTION
QUALITY SYMBOL	▽=0	▽=0			

GENERAL TOLERANCES (UNLESS SPECIFIED)		DIMENSION STYLE IN/MM		SCALE	DESIGN UNITS	THIRD ANGLE PROJECTION	
PLACES	TOLERANCE	IN	MM	---	INCH		
4 PLACES	±---	±---	±---			DRAWN BY: RSTONE DATE: 2014/07/17	
3 PLACES	±---	±.005				CHECKED BY: BARDEN DATE: ---	
2 PLACES	±0.13	±.01				APPROVED BY: JFMURPHY DATE: 2014/08/02	
1 PLACE	±0.3	±---				MATERIAL NO. SEE PART LEGEND	
ANGULAR ±---°				DRAFT WHERE APPLICABLE MUST REMAIN WITHIN DIMENSIONS		DOCUMENT NO. SD-38721-010	
SIZE C				THIS DRAWING CONTAINS INFORMATION THAT IS PROPRIETARY TO MOLEX INCORPORATED AND SHOULD NOT BE USED WITHOUT WRITTEN PERMISSION			
						SHEET NO. 1 OF 1	