

PART NUMBER	REVISION	DESCRIPTION	FEED TYPE
2266003-1	D	FINE CRIMP HEIGHT ADJUST	MECHANICAL
2266003-2	E	FINE CRIMP HEIGHT ADJUST	PNEUMATIC
7-2266003-1	D	MECHANICAL AND CRIMP TOOLING KIT	MECHANICAL
7-2266003-2	E	PNEUMATIC AND CRIMP TOOLING KIT	PNEUMATIC
7-2266003-7	B	CRIMP TOOLING KIT	-

ATLANTIC VERSION TERMINATOR INTERFACE ADAPTER

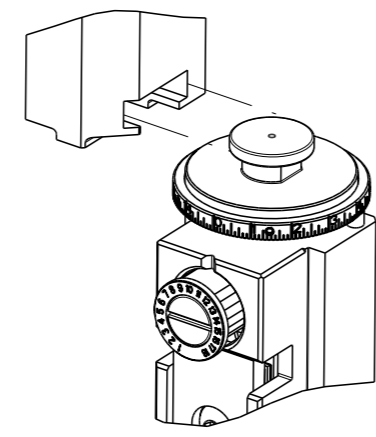

APPLICATOR DATA		
CRIMP	SIZE	TYPE
WIRE	2.45 mm [.096]	F
INSUL	3.20 mm [.126]	O

APPLICATOR INSTRUCTIONS 408-35042

TERMINAL DATA: FCI TERMINAL		FCI CRIMP SPECIFICATION	
TERMINAL NAME: 2.8mm APEX TERMINAL FEMALE			
WIRE STRIP LENGTH		INSULATION DIAMETER RANGE	
4.80-5.60 mm [.189-.220 IN]		Ø2.10-2.80 mm [.083-.110 IN]	
TERMINAL APPLICATION SPECIFICATION	C15005-CUST Rev 5		
TERMINALS APPLIED			
TE TERMINAL	FCI TERMINAL	TE TERMINAL	CHRYSLER/FORD TERMINAL
1572825-1	54001400(40)	1572825-7	4687767-29
1572825-2	54001402	1572825-8	4707172-14
1572825-3	54001403(44)	1572825-9	4667819-14
1572825-4	JPT141129	1-1572825-0	F8VB-14474AA
1572825-5	JPT141129G(1)	1-1572825-1	54001431
1572825-6	JPT141166AU(6)		

WIRE SIZE	CRIMP HEIGHT mm [INCH]	CRIMP HEIGHT REFERENCE SETTING
14 AWG OR 2.50mm ²	1.70+/-0.05 [.067+/-0.002]	8.7
16 AWG OR 1.50mm ²	1.50+/-0.05 [.059+/-0.002]	10.7

- 1. RECOMMENDED SPARE PARTS
- 2. REFER TO SUPPLIED INSTRUCTION SHEET FOR CLEANING, LUBRICATION AND STORAGE OF APPLICATOR.
- 3. APPLY PART NUMBER 2-23419-6 LOCTITE TO THREADS OF ITEM 242.
- 4. CRIMP HEIGHT REFERENCE SETTING WAS THE SETTING USED WHEN THE APPLICATOR WAS QUALIFIED AT THE FACTORY. ADJUSTMENT MAY BE NECESSARY WHEN RUNNING APPLICATOR IN THE FIELD.
- 5. TERMINAL LUBRICANT IS RECOMMENDED.
- 6. UNLESS SPECIFIED OTHERWISE TORQUE VALUES SHALL BE USED PER DOCUMENT, 101-35000.

***WARNING**
 ON INSTALLATION, SET WIRE DISC TO CRIMP HEIGHT REFERENCE SETTING FOR LARGEST WIRE SIZE. CRIMP HEIGHT REFERENCE SETTINGS GREATER THAN THE VALUE SHOWN MAY CAUSE DAMAGE TO THE CRIMP TOOLING, REFER TO THE INSTRUCTION SHEET FOR PROPER SETUP AND ADJUSTMENTS.

ATLANTIC VERSION
 Shown on sheets 1 of 4 & 2 of 4
 (Pacific version shown on sheets 3 of 4 & 4 of 4)

LOC	DIST	REVISIONS					
A	66	#	LY#	DESCRIPTION	DATE	OWN	APVD
		C		ECR-17-015016	11OCT2017	JAH	JDG
		D		ECR-18-007331	15MAY2018	MZ	JDG
		D1		ECR-18-012906	17AUG2018	FL	CT
		E		ECR-20-016145	12NOV2020	JWC	TE

-	1	-	1	-	2119641-1	FEED CAM, AIR FEED	248
-	1	1	1	1	2119082-8	CAM, SNAIL, INSULATION ADJUSTMENT	244
-	1	1	1	1	2079764-1	WASHER, WAVE SPRING, CREST-TO-CREST	243
-	1	1	1	1	2119083-1	RETAINER, INSULATION DIAL	242
-	1	1	1	1	7-18023-7	SCR, SKT HD CAP M3 X 4.0	241
-	-	1	-	1	2119580-1	MECHANICAL FEED ASSEMBLY	239
-	1	-	1	-	2844940-1	AIR FEED MODULE	238
-	REF	REF	REF	REF	994970-2	COUNTER, MAGNETIC	164
-	1	1	1	1	2119955-1	ASSY, LUBRICATOR, SIDE FEED	113
-	1	1	1	1	2844908-1	SCREW, LOCKING	99
-	1	1	1	1	2844907-1	POST, LOCKING	98
-	1	1	1	1	455888-5	SPACER, CRIMPER	82
-	1	1	1	1	5-547505-2	SPRING, COMPRESSION	77
-	1	1	1	1	854769-4	HOLDER, INS	74
-	1	1	1	1	1803607-3	DOCUMENTATION PACKAGE	71
-	1	1	1	1	2119740-1	TAG, IDENTIFICATION	67
-	2	2	2	2	2168078-1	SCREW, DRIVE, RH, RoHS, 2 x .188	66
-	1	1	1	1	2168083-2	SCR, SKT HD CAP, RoHS, M4 X 8.0	60
-	1	1	1	1	5-18022-5	SCR, HEX HD CAP, M4 X 6.0	59
-	1	1	1	1	21028-2	PIN, SLOTTED SPRING .062 X .250	58
-	1	1	1	1	1338683-8	FEED PAWL	56
-	4	4	4	4	2168083-3	SCR, SKT HD CAP, RoHS, M4 X 12.0	54
-	2	2	2	2	1-2168083-0	SCR, SKT HD CAP, RoHS, M4 X 10	53
-	1	1	1	1	5018030-1	NUT, HEX, REG, RoHS, M3	52
-	1	1	1	1	811242-5	BUMPER, HOLD DOWN	51
-	1	1	1	1	690753-2	SPACER, TONKER	50
-	1	2	1	2	18023-9	SCR, SKT HD CAP M4 X 6.0	49
-	-	1	-	1	2119652-1	FEED CAM, PRE FEED	48
-	-	1	-	1	2119653-1	FEED CAM, POST FEED	47
-	1	1	1	1	1803583-9	APPLICATOR BASIC ASSEMBLY, SF	46
-	1	1	1	1	1803515-1	RAM ASSEMBLY, SF ATLANTIC	44
-	1	1	1	1	1803602-1	SCR, BHSC, RoHS (M8 X 25)	41
-	1	1	1	1	1752356-3	SUPPORT, TERMINAL	34
-	2	2	2	2	2079383-5	SCR, BHSC, RoHS (M4 X 20)	33
-	2	2	2	2	3-2844962-0	SPACER, CYLINDRICAL, STRIP GUIDE	30
-	1	1	1	1	2844992-1	ASSEMBLY, STRIP GUIDE	29
-	1	1	1	1	455888-3	SPACER, CRIMPER	28
-	1	1	1	1	1320928-2	STRIP GUIDE	24
-	1	1	1	1	2168083-2	SCR, SKT HD CAP, RoHS, M4 X 8.0	21
-	2	2	2	2	1-18028-2	WASHER, FLAT, REG M4	20
-	1	1	1	1	2119533-1	STRIPPER, SIDE FEED	19
-	1	1	1	1	2119806-1	INSERT, SHEAR	13
-	1	1	1	1	3-22280-3	SPRING, COMPRESSION	12
-	1	1	1	1	1-356885-4	STOP, SHEAR	11
-	1	1	1	1	2119805-1	SHEAR HOLDER, FRONT	10
-	1	1	1	1	1803095-1	FLOATING SHEAR, FRONT	9
-	1	2	2	1	1803056-4	ANVIL, COMBINATION	8
-	-	-	-	-	-	-	7
-	-	-	-	-	-	-	6
-	1	1	1	1	2119780-9	DEPRESSOR, SHEAR	5
-	1	1	1	1	238011-4	BLOCK, CRIMPER SPACER	4
-	1	2	2	1	3-1803019-2	CRIMPER, INSULATION O	3
-	1	1	1	1	455888-9	SPACER, CRIMPER	2
-	1	2	2	1	3-568176-3	CRIMPER, WIRE	1
-	77	-72	-71	-2	-1	PART NO	ITEM NO

DIMENSIONS:		TOLERANCES UNLESS OTHERWISE SPECIFIED:		OWN	CHK	APVD	NAME
mm	0 PLC ±	1 PLC ±	2 PLC ±	26 JUL 2013	J. STAKEM	26 JUL 2013	J. ELBIN
	3 PLC ±	4 PLC ±	ANGLES ±		G. BAILEY		
MATERIAL	FINISH	WEIGHT					

Customer Accessible Production Drawing	SCALE 1:2	SHEET 1 OF 4	REV E
--	-----------	--------------	-------

LOC	DIST	REVISIONS			
A	66	REV	DATE	OWN	APVD
-	-	SEE SHEET 1	-	-	-

FEED TYPE MECHANICAL

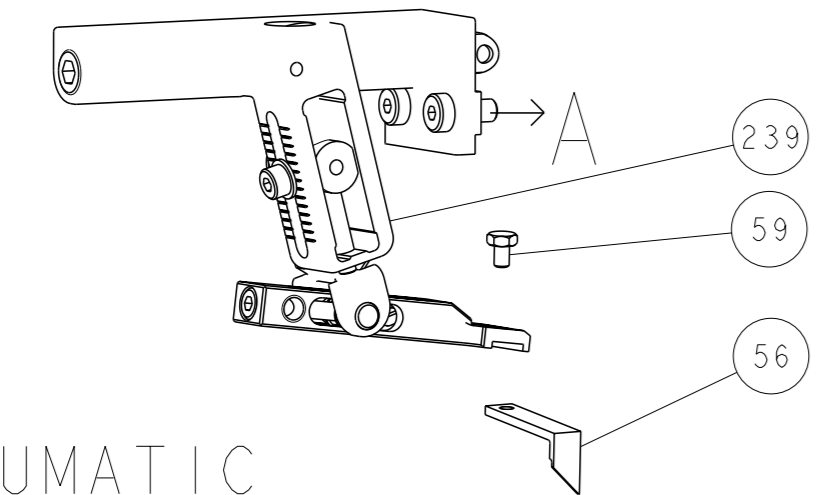

PNEUMATIC

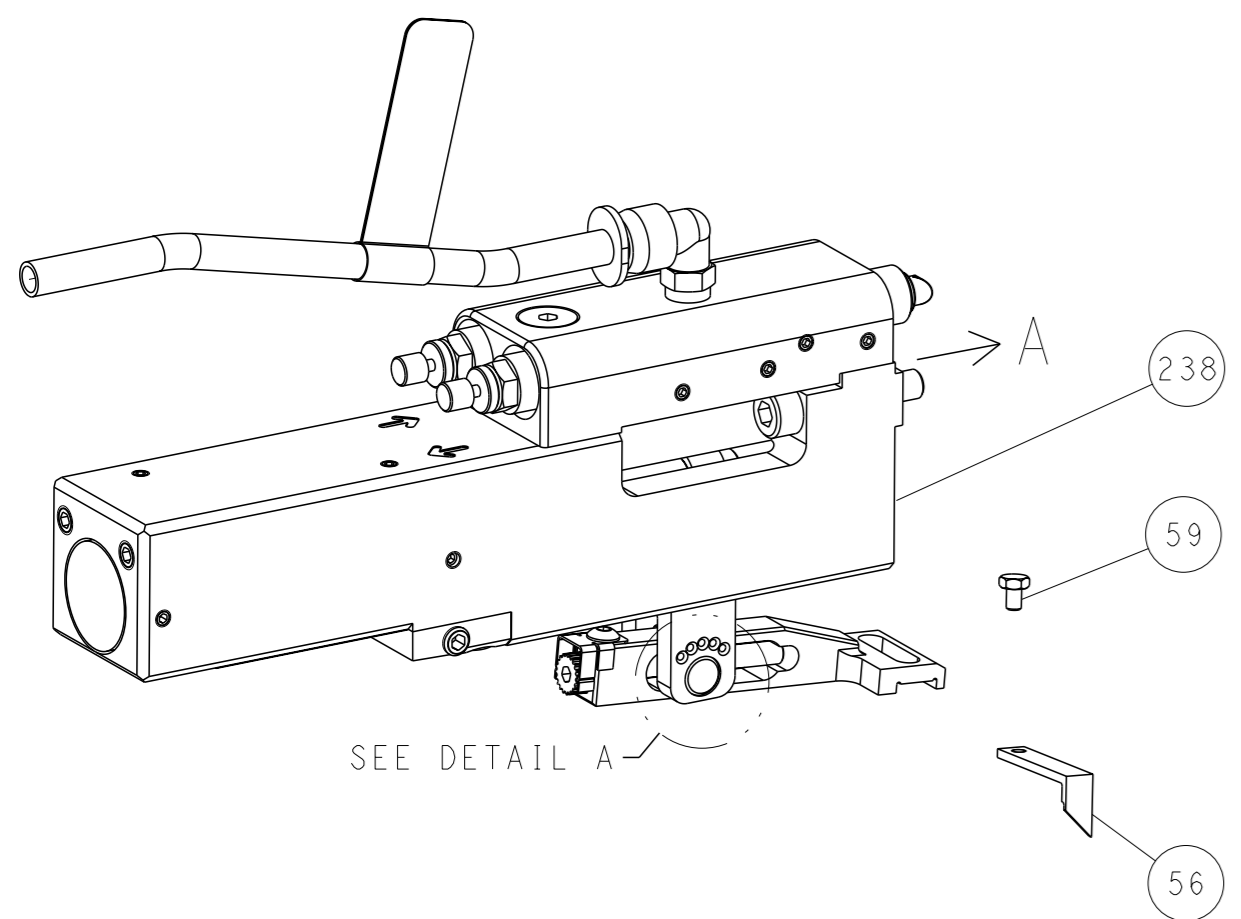

FEED SPRING SETTING POSITION (SHOWN FROM REAR SIDE)

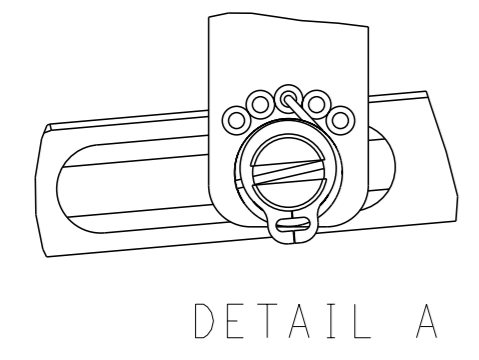

DETAIL A

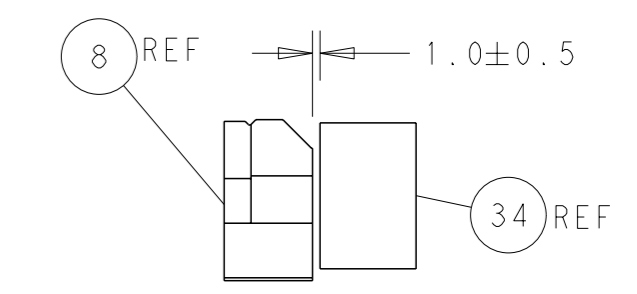
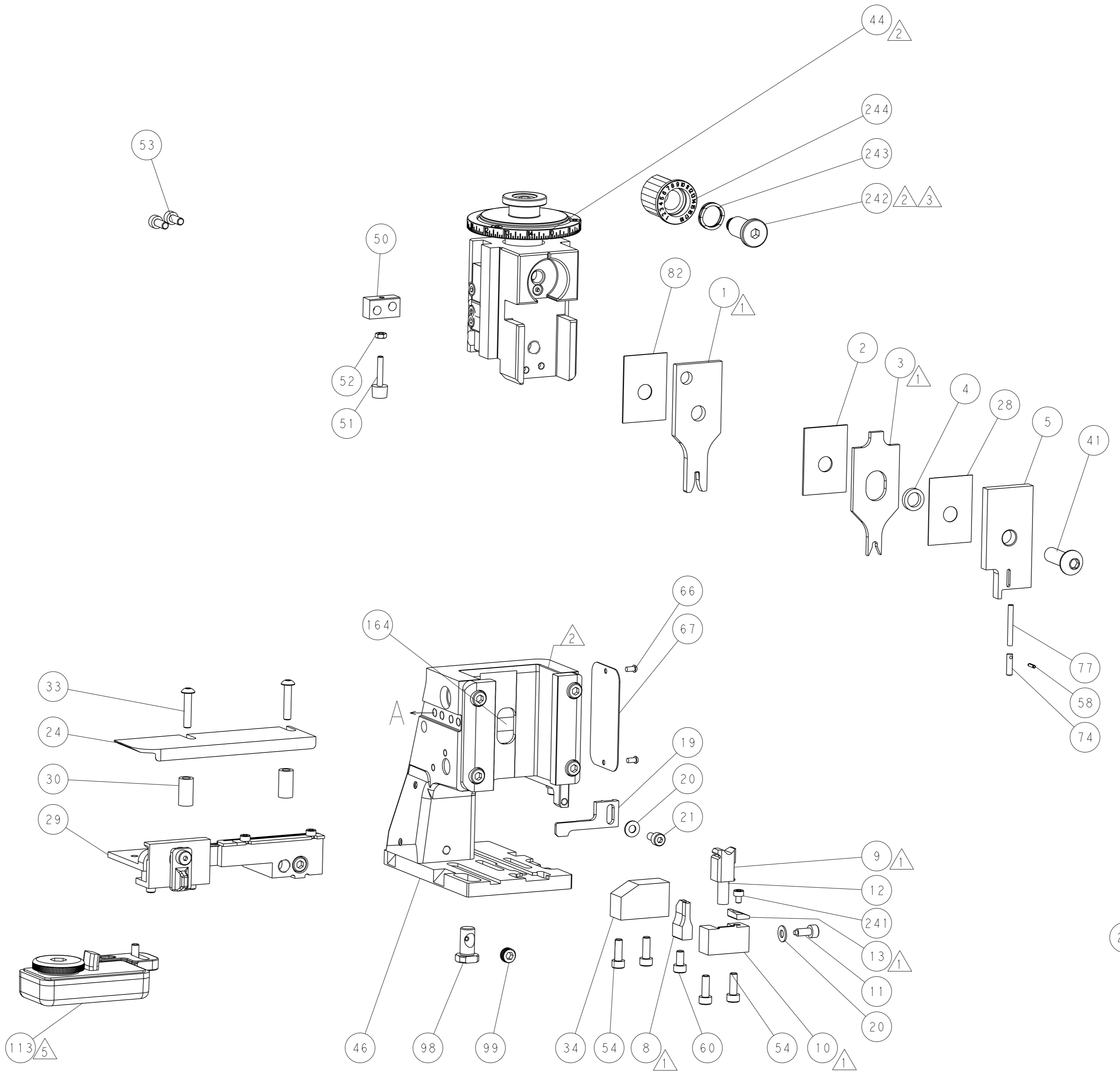

TERMINAL SUPPORT LOCATION

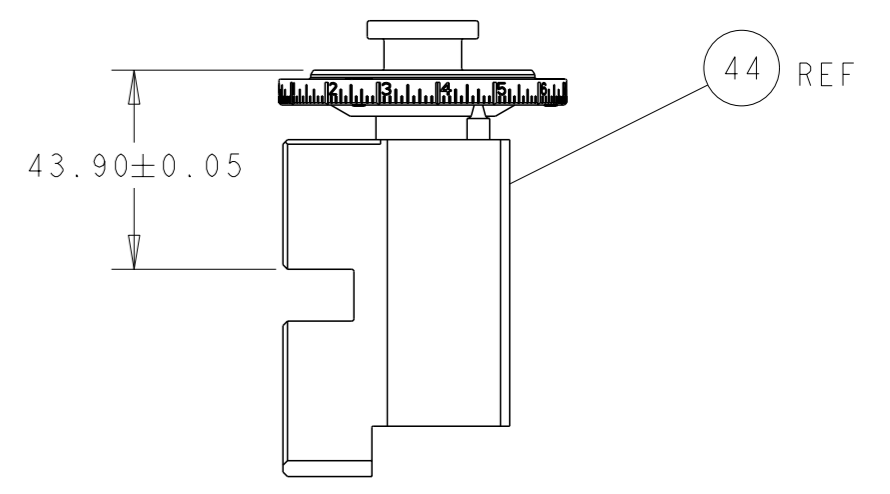

RAM SET-UP

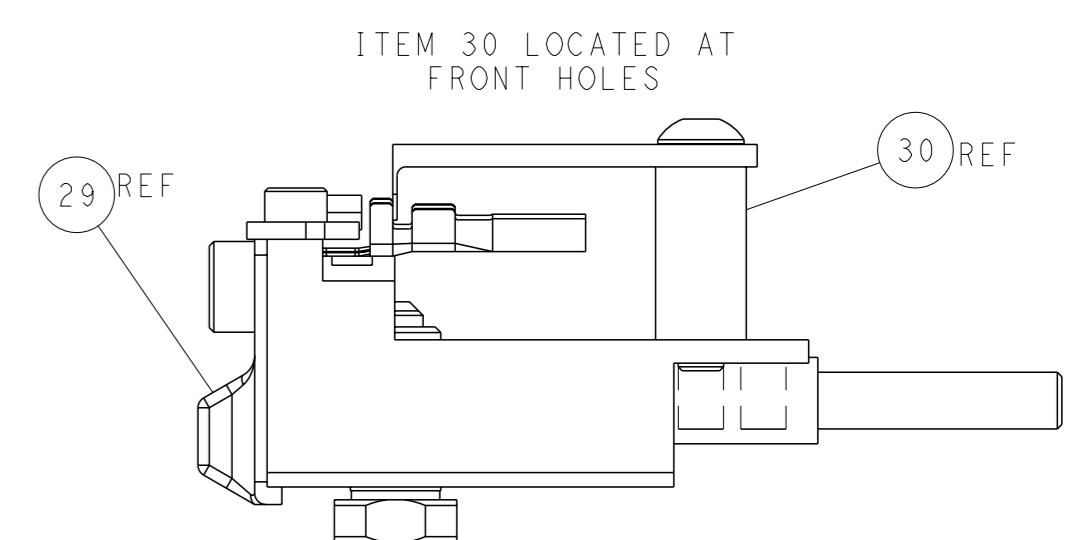

FEED TRACK POSITION GUIDE BY INSULATION BARREL

CAM POSITIONS

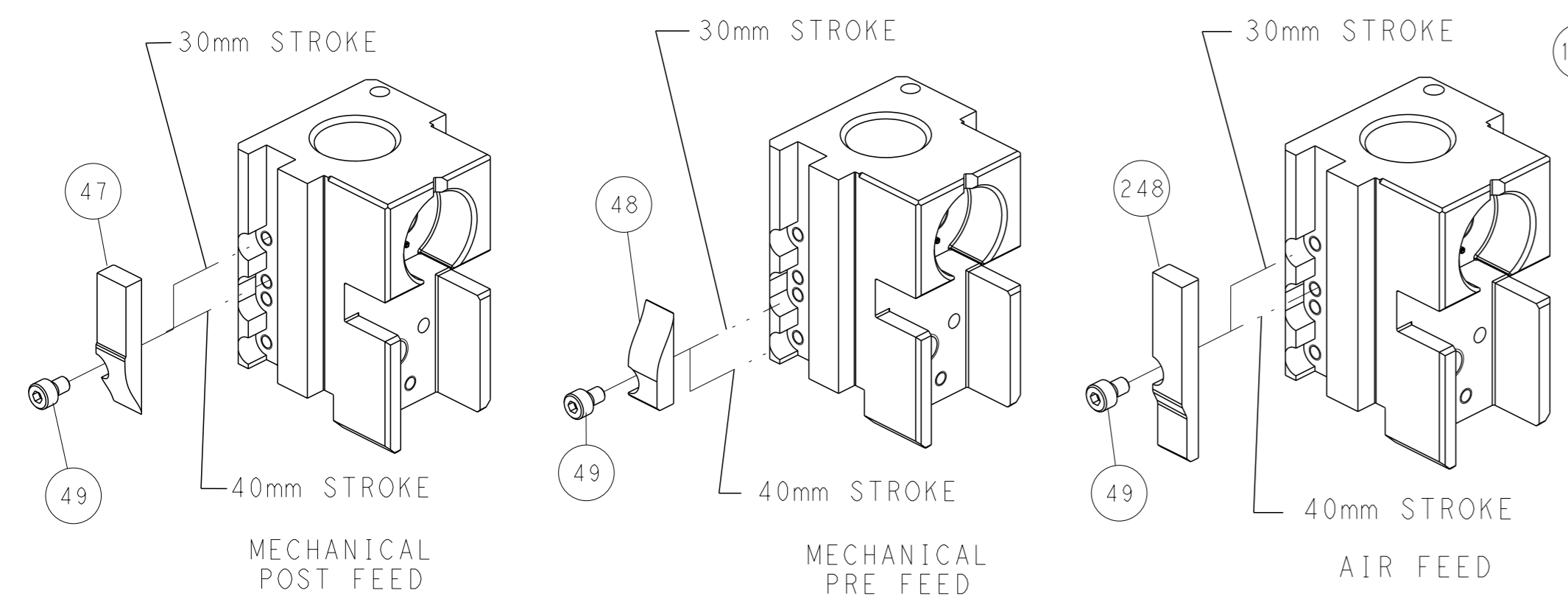

ATLANTIC VERSION
 Shown on sheets 1 of 4 & 2 of 4
 (Pacific version shown on sheets 3 of 4 & 4 of 4)

DIMENSIONS: mm 		TOLERANCES UNLESS OTHERWISE SPECIFIED: 0 PLC ± 1 PLC ± 2 PLC ± 3 PLC ± 4 PLC ± ANGLES ±		OWN: R. STAKEM 26 JUL 2013 CHK: G. BAILEY 26 JUL 2013 APVD: J. ELBIN 26 JUL 2013 PRODUCT SPEC: APPLICATION SPEC: WEIGHT: - MATERIAL: -		NAME: Ocean Side Feed Applicator SIZE: A1 CAGE CODE: 00779 DRAWING NO: C=2266003 SCALE: 1:2 SHEET: 2 of 4 REV: E		TE Connectivity Harrisburg, PA 17105-3608 RESTRICTED TO: -	
--------------------	--	---	--	--	--	--	--	--	--

PART NUMBER	REVISION	DESCRIPTION	FEED TYPE
2-2266003-1	D	FINE CRIMP HEIGHT ADJUST	MECHANICAL
2-2266003-2	E	FINE CRIMP HEIGHT ADJUST	PNEUMATIC
7-2266003-7	B	CRIMP TOOLING KIT	-

PACIFIC VERSION TERMINATOR
INTERFACE ADAPTER

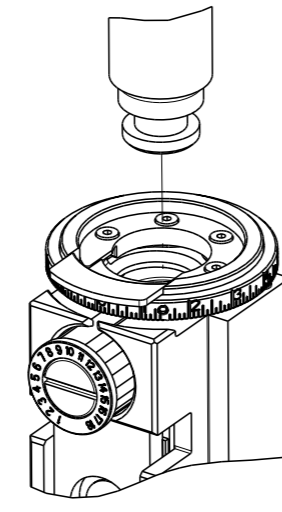

APPLICATOR DATA		
CRIMP	SIZE	TYPE
WIRE	2.45 mm [.096]	F
INSUL	3.20 mm [.126]	O

APPLICATOR INSTRUCTIONS
408-35042

TERMINAL DATA: FCI TERMINAL		FCI CRIMP SPECIFICATION	
TERMINAL NAME: 2.8mm APEX TERMINAL FEMALE			
WIRE STRIP LENGTH 4.80-5.60 mm [.189-.220 IN]		INSULATION DIAMETER RANGE Ø2.10-2.80 mm [.083-.110 IN]	
TERMINAL APPLICATION SPECIFICATION C15005-CUST Rev 5			
TERMINALS APPLIED			
TE TERMINAL	FCI TERMINAL	TE TERMINAL	CHRYSLER/FORD TERMINAL
1572825-1	540014001(40)	1572825-7	4687767-29
1572825-2	54001402	1572825-8	4707172-14
1572825-3	54001403(44)	1572825-9	4667819-14
1572825-4	JPT141129	1-1572825-0	F8VB-14474AA
1572825-5	JPT141129G(1)	1-1572825-1	54001431
1572825-6	JPT141166AU(G)		

WIRE SIZE	CRIMP HEIGHT mm [INCH]	CRIMP HEIGHT REFERENCE SETTING
14 AWG OR 2.50mm2	1.70+/-0.05 [.067+/-0.002]	8.7
16 AWG OR 1.50mm2	1.50+/-0.05 [.059+/-0.002]	10.7

- RECOMMENDED SPARE PARTS
 - REFER TO SUPPLIED INSTRUCTION SHEET FOR CLEANING, LUBRICATION AND STORAGE OF APPLICATOR.
 - APPLY PART NUMBER 2-23419-6 LOCTITE TO THREADS OF ITEM 242.
 - CRIMP HEIGHT REFERENCE SETTING WAS THE SETTING USED WHEN THE APPLICATOR WAS QUALIFIED AT THE FACTORY. ADJUSTMENT MAY BE NECESSARY WHEN RUNNING APPLICATOR IN THE FIELD.
 - TERMINAL LUBRICANT IS RECOMMENDED.
6. UNLESS SPECIFIED OTHERWISE TORQUE VALUES SHALL BE USED PER DOCUMENT, 101-35000.

***WARNING**
ON INSTALLATION, SET WIRE DISC TO CRIMP HEIGHT REFERENCE SETTING FOR LARGEST WIRE SIZE. CRIMP HEIGHT REFERENCE SETTINGS GREATER THAN THE VALUE SHOWN MAY CAUSE DAMAGE TO THE CRIMP TOOLING, REFER TO THE INSTRUCTION SHEET FOR PROPER SETUP AND ADJUSTMENTS.

PACIFIC VERSION
Shown on sheets 3 of 4 & 4 of 4
(Atlantic version shown on sheets 1 of 4 & 2 of 4)

LOC	DIST	REVISIONS			
A	66	REV	DATE	BY	APPV
-	-	SEE SHEET 1	-	-	-

-	1	1	2119082-8	CAM, SNAIL, INSULATION ADJUSTMENT	244
-	1	1	2079764-1	WASHER, WAVE SPRING, CREST-TO-CREST	243
-	1	1	2119083-1	RETAINER, INSULATION DIAL	242
-	1	1	7-18023-7	SCR, SKT HD CAP M3 X 4.0	241
-	-	1	2119580-1	MECHANICAL FEED ASSEMBLY	239
-	1	-	2844940-1	AIR FEED MODULE	238
-	REF	REF	994970-2	COUNTER, MAGNETIC	164
-	1	-	2119641-2	FEED CAM, AIR FEED	151
-	1	1	2168083-8	SCR, SKT HD CAP, RoHS, M4 X 16	144
-	4	4	2168083-9	SCR, SKT HD CAP, RoHS, M4 X 20	143
-	-	1	2119653-2	FEED CAM, POST FEED	142
-	1	1	1-1803583-0	APPLICATOR BASIC ASSEMBLY, SF	141
-	1	1	1803516-1	RAM ASSEMBLY, SF PACIFIC	140
-	1	1	2119955-1	ASSY, LUBRICATOR, SIDE FEED	113
-	1	1	2844908-1	SCREW, LOCKING	99
-	1	1	2844907-1	POST, LOCKING	98
-	1	1	455888-5	SPACER, CRIMPER	82
-	1	1	5-547505-2	SPRING, COMPRESSION	77
-	1	1	854769-4	HOLDER, INS	74
-	1	1	1803607-3	DOCUMENTATION PACKAGE	71
-	1	1	2119740-1	TAG, IDENTIFICATION	67
-	2	2	2168078-1	SCREW, DRIVE, RH, RoHS, 2 x .188	66
-	1	1	5-18022-5	SCR, HEX HD CAP, M4 X 6.0	59
-	1	1	21028-2	PIN, SLOTTED SPRING .062 X .250	58
-	1	1	1338683-8	FEED PAWL	56
-	2	2	1-2168083-0	SCR, SKT HD CAP, RoHS, M4 X 10	53
-	1	1	5018030-1	NUT, HEX, REG, RoHS, M3	52
-	1	1	811242-5	BUMPER, HOLD DOWN	51
-	1	1	690753-2	SPACER, TONKER	50
-	1	2	18023-9	SCR, SKT HD CAP M4 X 6.0	49
-	-	1	2119652-1	FEED CAM, PRE FEED	48
-	1	1	1803602-1	SCR, BHSC, RoHS (M8 X 25)	41
-	1	1	1752356-3	SUPPORT, TERMINAL	34
-	2	2	2079383-5	SCR, BHSC, RoHS (M4 X 20)	33
-	2	2	3-2844962-0	SPACER, CYLINDRICAL, STRIP GUIDE	30
-	1	1	2844992-1	ASSEMBLY, STRIP GUIDE	29
-	1	1	455888-3	SPACER, CRIMPER	28
-	1	1	1320928-2	STRIP GUIDE	24
-	1	1	2168083-2	SCR, SKT HD CAP, RoHS, M4 X 8.0	21
-	2	2	1-18028-2	WASHER, FLAT, REG M4	20
-	1	1	2119533-1	STRIPPER, SIDE FEED	19
-	1	1	2119806-1	INSERT, SHEAR	13
-	1	1	3-22280-3	SPRING, COMPRESSION	12
-	1	1	1-356885-4	STOP, SHEAR	11
-	1	1	2119805-1	SHEAR HOLDER, FRONT	10
-	1	1	1803095-1	FLOATING SHEAR, FRONT	9
-	1	1	1803056-4	ANVIL, COMBINATION	8
-	-	-	-	-	7
-	-	-	-	-	6
-	1	1	2119780-9	DEPRESSOR, SHEAR	5
-	1	1	238011-4	BLOCK, CRIMPER SPACER	4
-	1	1	3-1803019-2	CRIMPER, INSULATION O	3
-	1	1	455888-9	SPACER, CRIMPER	2
-	1	1	3-568176-3	CRIMPER, WIRE	1
-	77	22	21	PART NO	ITEM NO

DIMENSIONS:		TOLERANCES UNLESS OTHERWISE SPECIFIED:		OWN: H. STAKEM 26 JUL 2013	NAME: TE Connectivity Harrisburg, PA 17105-3608
mm		0 PLC ±		CHK: G. BAILEY 26 JUL 2013	
APPROVALS:		FINISH: *		APPROVALS:	PRODUCT SPEC:
MATERIAL:		FINISH:		APPLICATOR SPEC:	SIZE: A1
WEIGHT:		SCALE: 1:2		Customer Accessible Production Drawing	SHEET 3 OF 4

LOC		DIST		REVISIONS			
A	66	P	LYR	DESCRIPTION	DATE	OWN	APVD
		-		SEE SHEET 1			

FEED TYPE MECHANICAL

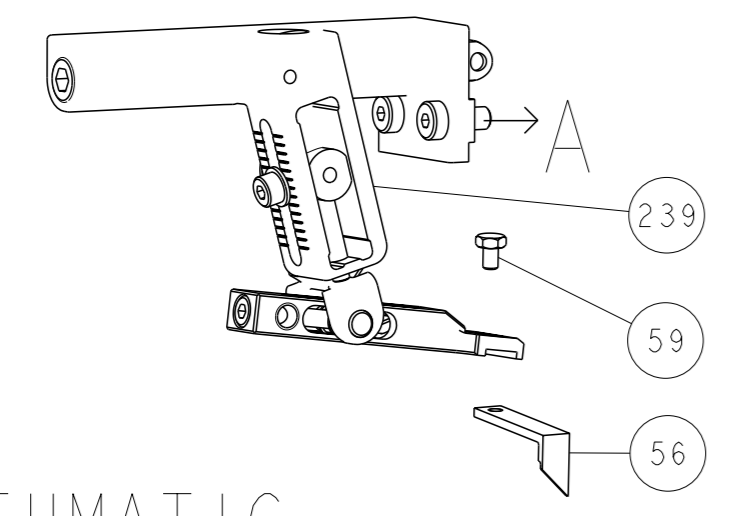

PNEUMATIC

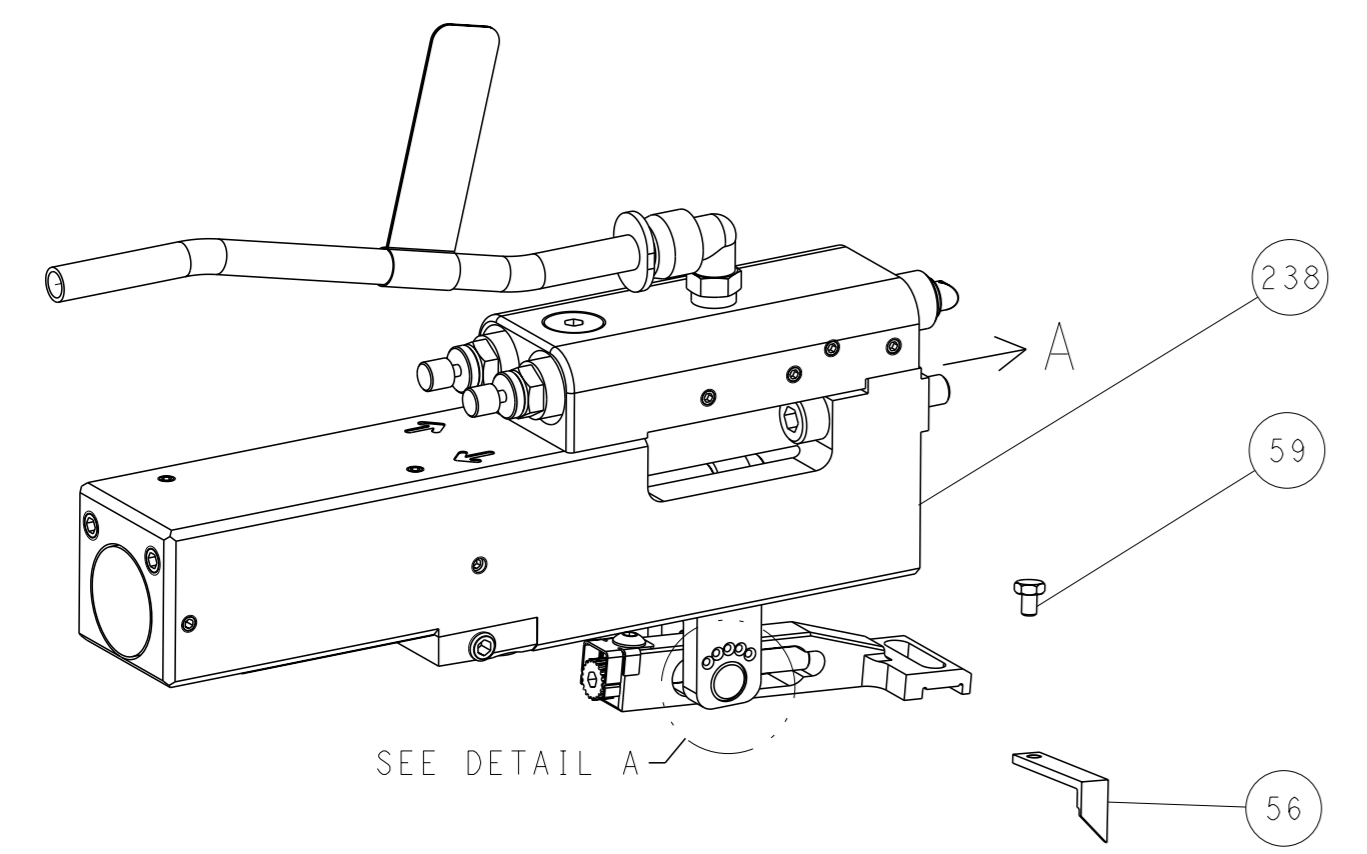

FEED SPRING SETTING POSITION (SHOWN FROM REAR SIDE)

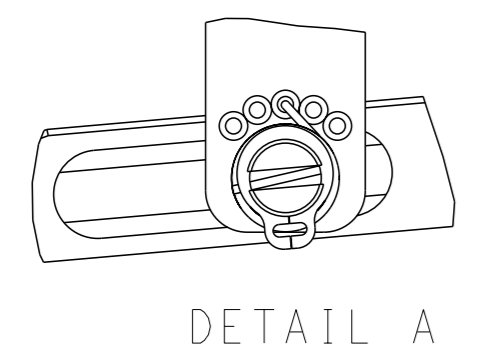

CAM POSITIONS

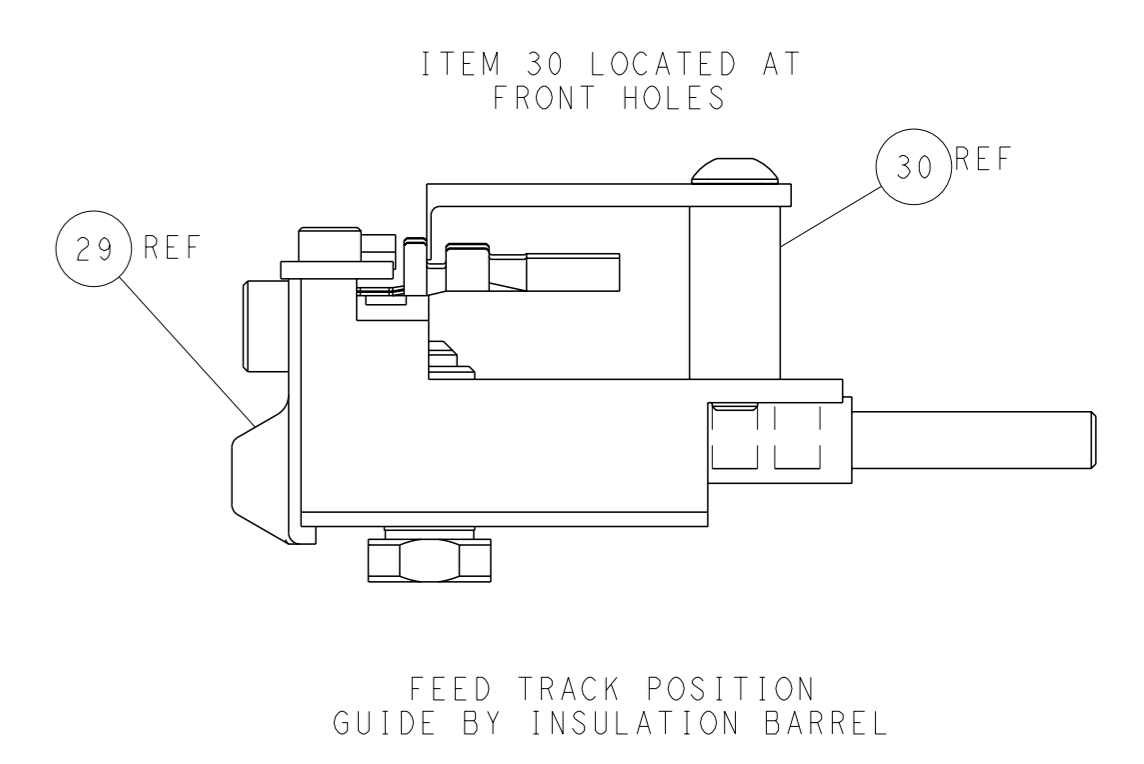
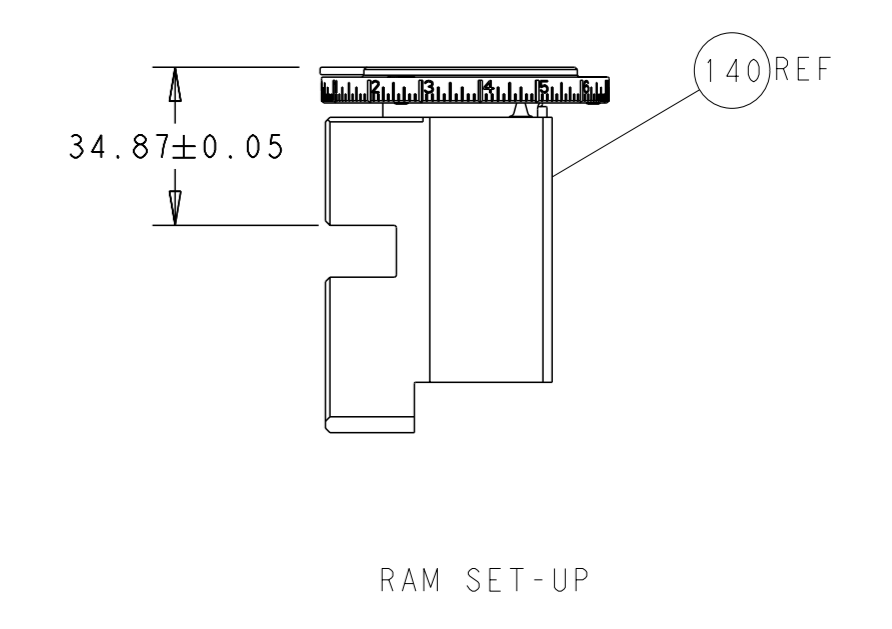
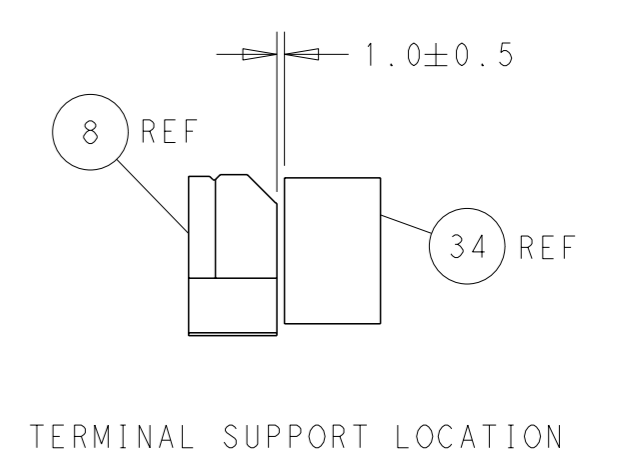
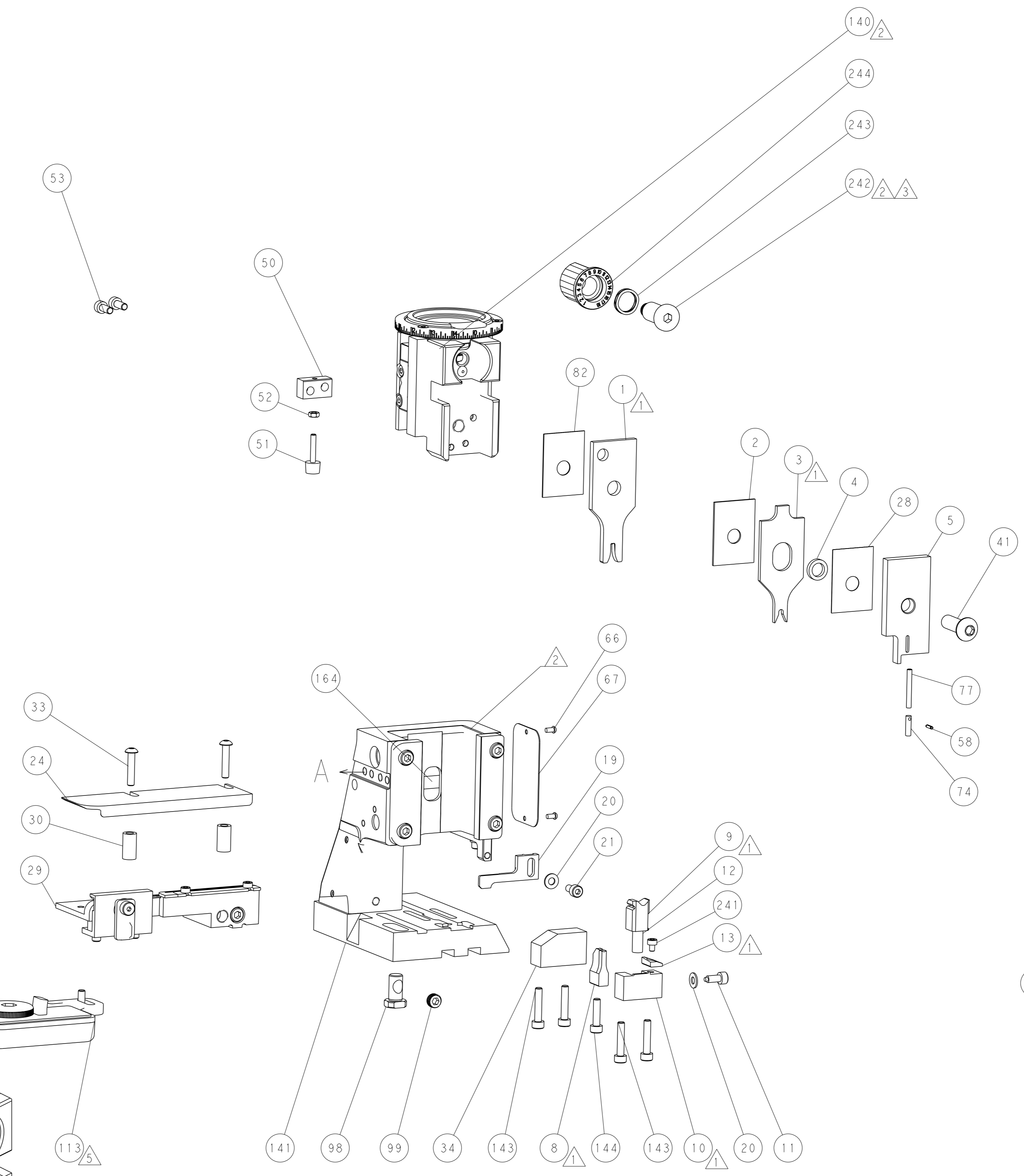
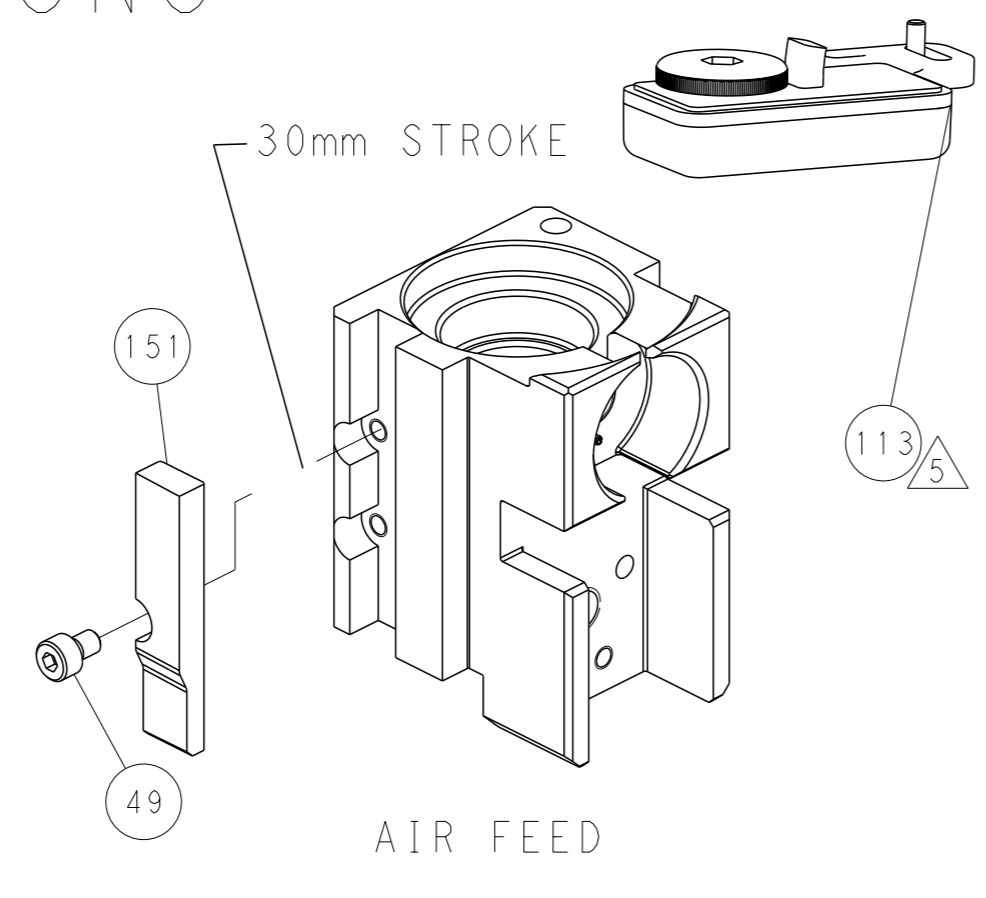
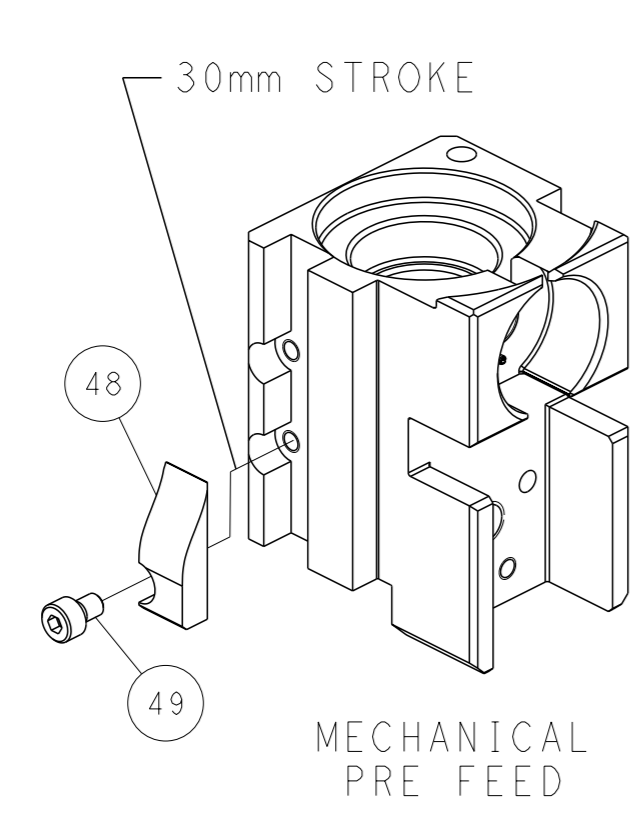
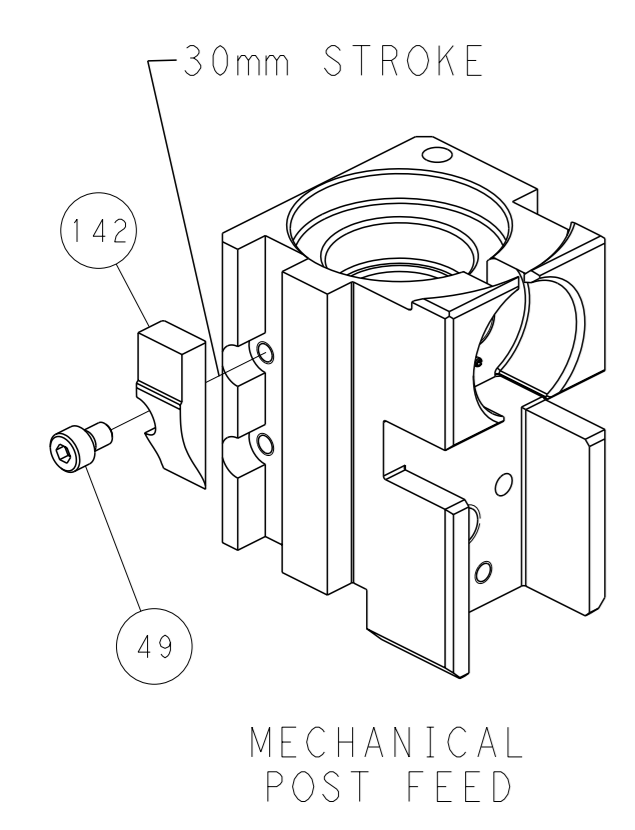

PACIFIC VERSION
 Shown on sheets 3 of 4 & 4 of 4
 (Atlantic version shown on sheets 1 of 4 & 2 of 4)

<small>THIS DRAWING IS UNPUBLISHED. RELEASED FOR PUBLICATION. IT IS SUBJECT TO CHANGE AND THE USER SHALL BE RESPONSIBLE FOR VERIFYING DIMENSIONS AND TOLERANCES BEFORE USE. CONTACT THE SUPPLIER FOR THE LATEST REVISION.</small>		OWN: H. STAKEM CHK: G. BAILEY APVD: T. ELBIN DATE: 26 JUL 2013 PRODUCT SPEC: - APPLICATION SPEC: - WEIGHT: - MATERIAL: -	NAME: Ocean Side Feed Applicator SIZE: A1 CAGE CODE: 00779 DRAWING NO: C=2266003 SCALE: 1:2 SHEET: 4 of 4 REV: E	TE Connectivity Harrisburg, PA 17105-3608
---	--	---	--	--