

PART NUMBER	REVISION	DESCRIPTION	FEED TYPE
2151516-1	E	FINE CRIMP HEIGHT ADJUST	MECHANICAL
2151516-2	E	FINE CRIMP HEIGHT ADJUST	PNEUMATIC
7-2151516-1	E	MECHANICAL AND CRIMP TOOLING KIT	MECHANICAL
7-2151516-2	E	PNEUMATIC AND CRIMP TOOLING KIT	PNEUMATIC
7-2151516-7	A	CRIMP TOOLING KIT	-

ATLANTIC VERSION TERMINATOR INTERFACE ADAPTER

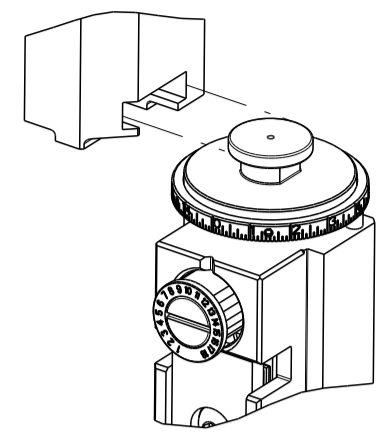

APPLICATOR DATA		
CRIMP	SIZE	TYPE
WIRE	1.40 mm (.055)	F
INSUL	-	-

APPLICATOR INSTRUCTIONS 408-35042

TERMINAL DATA: TE TERMINAL		TE CRIMP SPECIFICATION	
TERMINAL NAME: SOCKET CONTACT FOR IMM DIA PIN			
WIRE STRIP LENGTH		INSULATION DIAMETER RANGE	
3.5-4.5 mm (.138-.177 IN)		∅	
TERMINAL APPLICATION SPECIFICATION	(A)114-18972	-	-
	(B)114-15132	-	-
TERMINALS APPLIED ³			
TE TERMINAL	TE TERMINAL	TE TERMINAL	TE TERMINAL
(A) 1564881-1	(A) 1-1564881-1	(A) 1564882-1	(A) 1-1564882-1
(B) 1801828-1	(B) 9-1801828-1	(B) 1801829-1	(B) 9-1801829-1

WIRE SIZE	CRIMP HEIGHT mm [INCH]	CRIMP HEIGHT REFERENCE SETTING
0.50mm2	0.86 +/- 0.03 [0.034 +/- .001]	6.4
0.35mm2	0.78 +/- 0.03 [0.031 +/- .001]	7.2

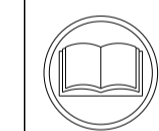

- ¹ RECOMMENDED SPARE PARTS
 - ² REFER TO SUPPLIED INSTRUCTION SHEET FOR CLEANING, LUBRICATION AND STORAGE OF APPLICATOR.
 - ³ TERMINAL LUBRICANT IS RECOMMENDED.
 - ⁴ CRIMP HEIGHT REFERENCE SETTING WAS THE SETTING USED WHEN THE APPLICATOR WAS QUALIFIED AT THE FACTORY. ADJUSTMENT MAY BE NECESSARY WHEN RUNNING APPLICATOR IN THE FIELD.
5. UNLESS SPECIFIED OTHERWISE TORQUE VALUES SHALL BE USED PER DOCUMENT, 101-35000.

***WARNING**
ON INSTALLATION, SET WIRE DISC TO CRIMP HEIGHT REFERENCE SETTING FOR LARGEST WIRE SIZE. CRIMP HEIGHT REFERENCE SETTINGS GREATER THAN THE VALUE SHOWN MAY CAUSE DAMAGE TO THE CRIMP TOOLING. REFER TO THE INSTRUCTION SHEET FOR PROPER SETUP AND ADJUSTMENTS.

ATLANTIC VERSION
Shown on sheets 1 of 4 & 2 of 4
(Pacific version shown on sheets 3 of 4 & 4 of 4)

LOC	DIST	REVISIONS					
A	66	P	LTN	DESCRIPTION	DATE	OWN	APVD
		C		ECR-17-003139	13MAR2017	TB	TE
		C1		ECR-18-009966	29JUN2018	YY	GB
		D		ECR-18-015830	05OCT2018	TB	CT
		E		ECR-23-169878	20MAR2023	JWC	TE

-	1	-	1	-	2119641-1	FEED CAM, AIR FEED	248	
-	1	1	1	1	7-18023-7	SCR, SKT HD CAP M3 X 4.0	241	
-	-	1	-	1	2119580-1	MECHANICAL FEED ASSEMBLY	239	
-	1	-	1	-	2844940-1	AIR FEED MODULE	238	
-	REF	REF	REF	REF	994970-2	COUNTER, MAGNETIC	164	
-	1	1	1	1	1-18028-2	WASHER, FLAT, REG M4	119	
-	1	1	1	1	2119955-1	ASSY, LUBRICATOR, SIDE FEED	113	
-	1	1	1	1	2844908-1	SCREW, LOCKING	99	
-	1	1	1	1	2844907-1	POST, LOCKING	98	
-	1	1	1	1	455888-5	SPACER, CRIMPER	82	
-	2	2	2	2	2168083-1	SCR, SKT HD CAP, RoHS, M3 X 8.0	79	
-	1	1	1	1	1633782-3	FENCE	78	
-	1	1	1	1	5-547505-2	SPRING, COMPRESSION	77	
-	1	1	1	1	854769-4	HOLDER, INS	74	
-	1	1	1	1	1803607-3	DOCUMENTATION PACKAGE	71	
-	1	1	1	1	2119740-1	TAG, IDENTIFICATION	67	
-	2	2	2	2	2168078-1	SCREW, DRIVE, RH, RoHS, 2 x .188	66	
-	1	1	1	1	2168083-2	SCR, SKT HD CAP, RoHS, M4 X 8.0	60	
-	1	1	1	1	5-18022-5	SCR, HEX HD CAP, M4 X 6.0	59	
-	1	1	1	1	21028-2	PIN, SLOTTED SPRING .062 X .250	58	
-	1	1	1	1	1338685-1	PAWL, FEED	56	
-	4	4	4	4	2168083-3	SCR, SKT HD CAP, RoHS, M4 X 12.0	54	
-	2	2	2	2	2168083-8	SCR, SKT HD CAP, RoHS, M4 X 16	53	
-	1	1	1	1	5018030-1	NUT, HEX, REG, RoHS, M3	52	
-	1	1	1	1	811242-5	BUMPER, HOLD DOWN	51	
-	1	1	1	1	690753-2	SPACER, TONKER	50	
-	1	2	1	2	18023-9	SCR, SKT HD CAP M4 X 6.0	49	
-	-	1	-	1	2119652-1	FEED CAM, PRE FEED	48	
-	-	1	-	1	2119653-1	FEED CAM, POST FEED	47	
-	1	1	1	1	1803583-9	APPLICATOR BASIC ASSEMBLY, SF	46	
-	1	1	1	1	1803515-1	RAM ASSEMBLY, SF ATLANTIC	44	
-	1	1	1	1	1803602-1	SCR, BHSC, RoHS (M8 X 25)	41	
-	1	1	1	1	1-1752356-9	SUPPORT, TERMINAL	34	
-	2	2	2	2	2079383-5	SCR, BHSC, RoHS (M4 X 20)	33	
-	2	2	2	2	2-2844962-3	SPACER, CYLINDRICAL, STRIP GUIDE	30	
-	1	1	1	1	2844992-1	ASSEMBLY, STRIP GUIDE	29	
-	1	1	1	1	1-455888-0	SPACER, CRIMPER	28	
-	1	1	1	1	1320928-2	STRIP GUIDE	24	
-	1	1	1	1	2168083-2	SCR, SKT HD CAP, RoHS, M4 X 8.0	21	
-	1	1	1	1	1-18028-2	WASHER, FLAT, REG M4	20	
-	1	1	1	1	2119533-1	STRIPPER, SIDE FEED	19	
-	1	1	1	1	2119806-1	INSERT, SHEAR	13	
-	1	1	1	1	3-22280-3	SPRING, COMPRESSION	12	
-	1	1	1	1	1-356885-4	STOP, SHEAR	11	
-	1	1	1	1	2119805-1	SHEAR HOLDER, FRONT	10	
-	1	1	1	1	1803095-1	FLOATING SHEAR, FRONT	9	
-	1	2	2	1	1	6-1633139-9	ANVIL, COMBINATION	8
-	1	1	1	1	1-240641-4	SPACER	7	
-	-	-	-	-	-	-	6	
-	1	1	1	1	2119780-9	DEPRESSOR, SHEAR	5	
-	-	-	-	-	-	-	4	
-	-	-	-	-	-	-	3	
-	-	-	-	-	-	-	2	
-	1	2	2	1	1	1803125-6	CRIMPER, WIRE	1

ITEM NO	PART NO	DESCRIPTION
-77	-72	-71
-2	-1	

OWN	Y. YIN	01APR2013
CHK	G. BAILEY	01APR2013
APVD	J. GUO	01APR2013
NAME	Ocean Side Feed Applicator	
SIZE	CAGE CODE	DRAWING NO
A1	00779	2151516
CUSTOMER ACCESSIBLE PRODUCTION DRAWING		
SCALE	1:2	SHEET 1 OF 4
REV	E	

REVISONS		DATE	OWN	APVD
LOC	DIST			
A	66			
P	LYN			
DESCRIPTION				
SEE SHEET 1				

FEED TYPE MECHANICAL

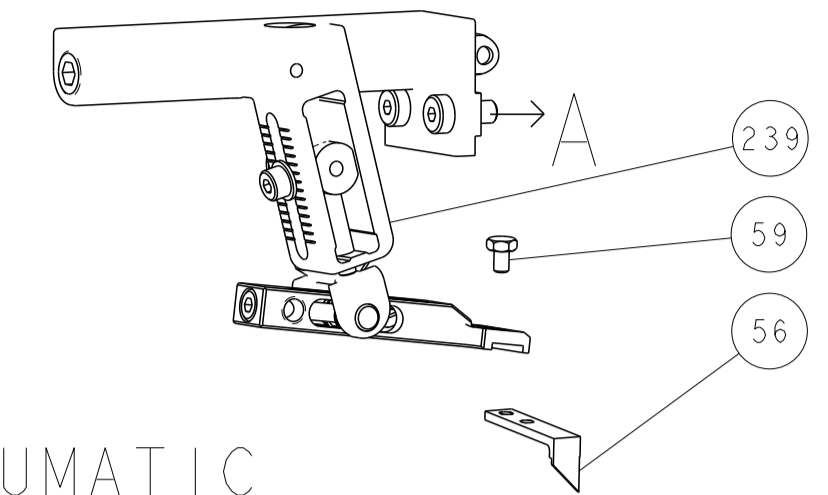

PNEUMATIC

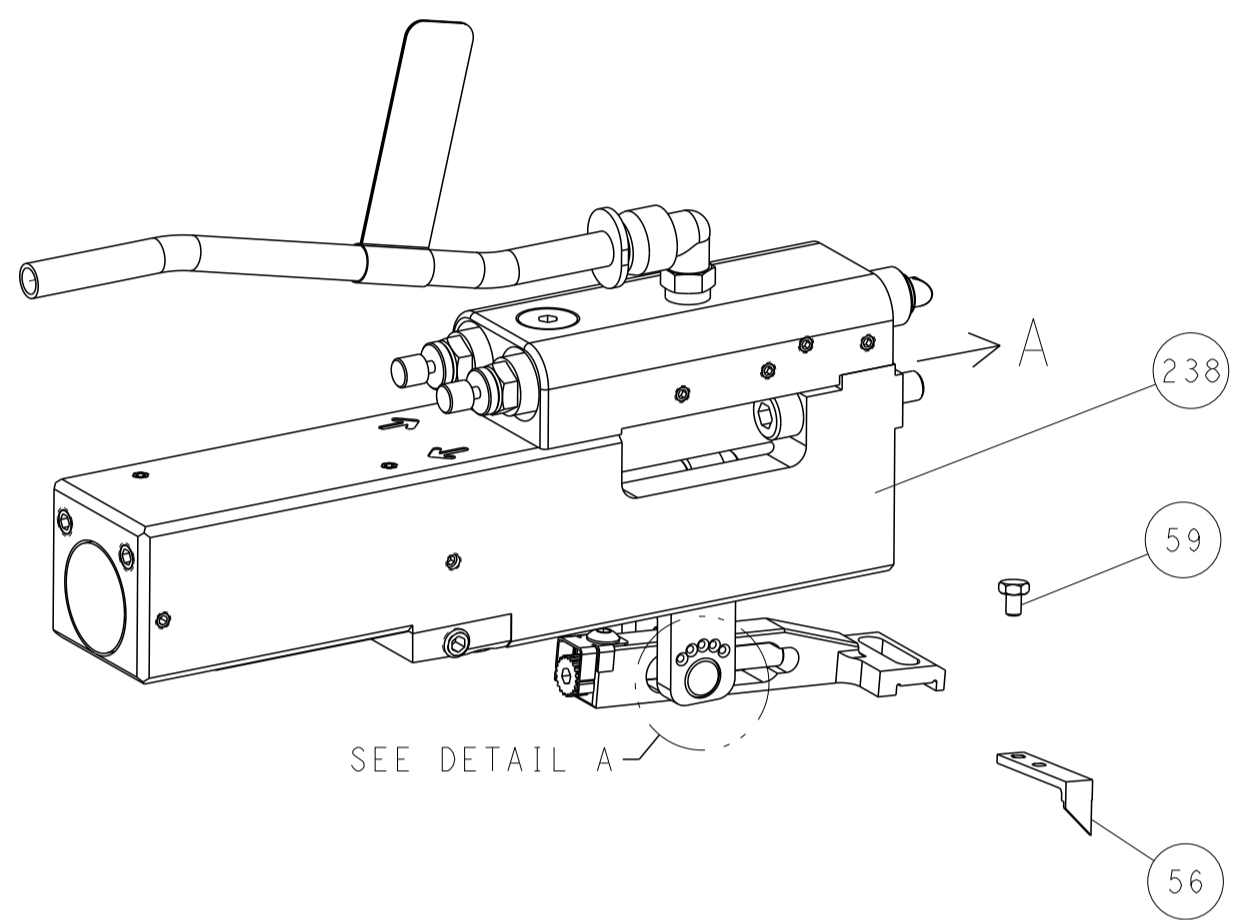

FEED SPRING SETTING POSITION (SHOWN FROM REAR SIDE)



DETAIL A

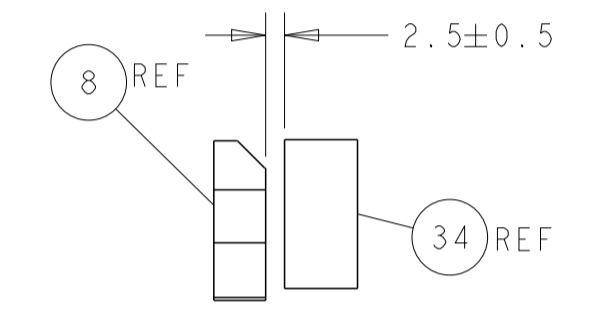
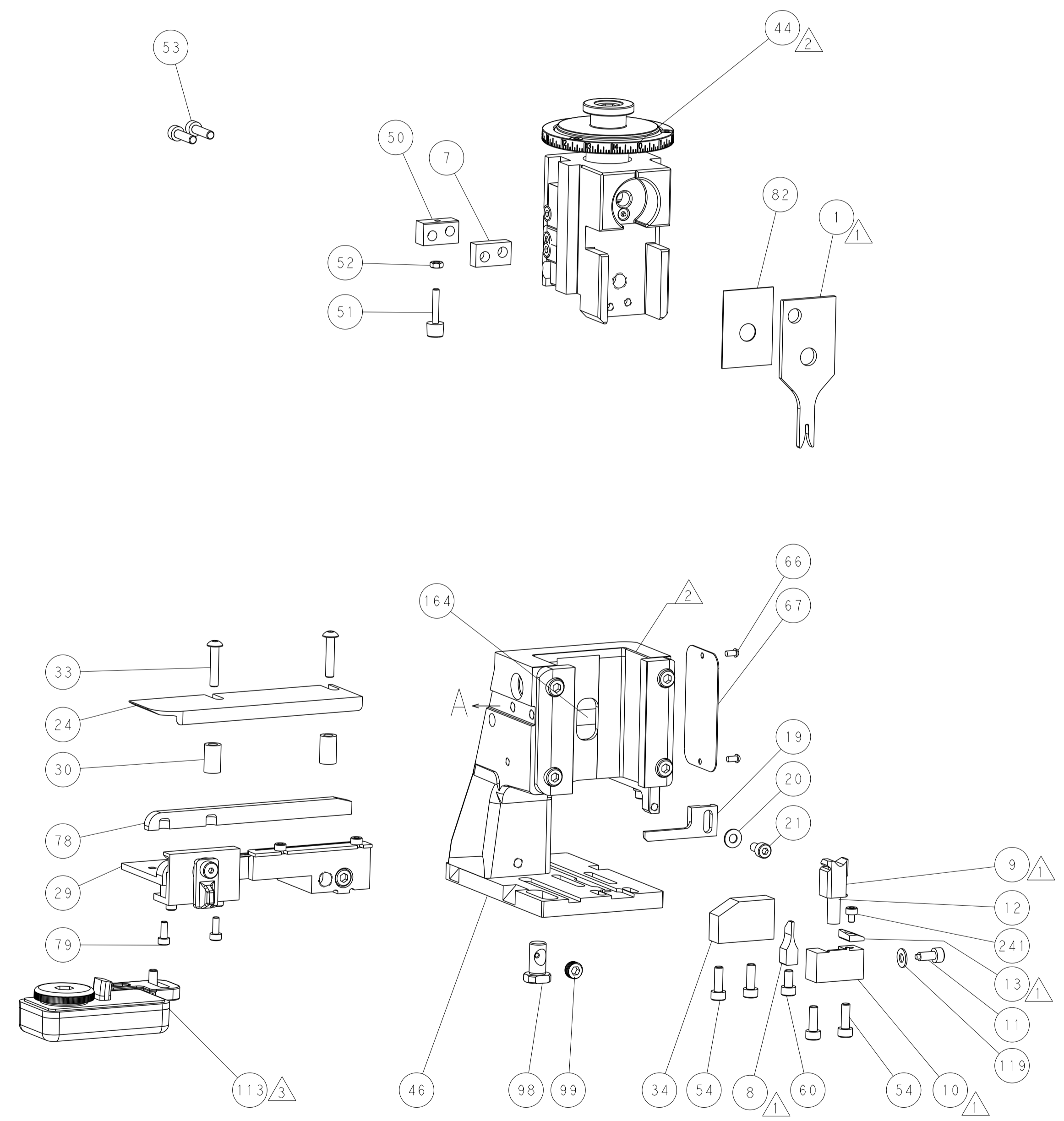

TERMINAL SUPPORT LOCATION

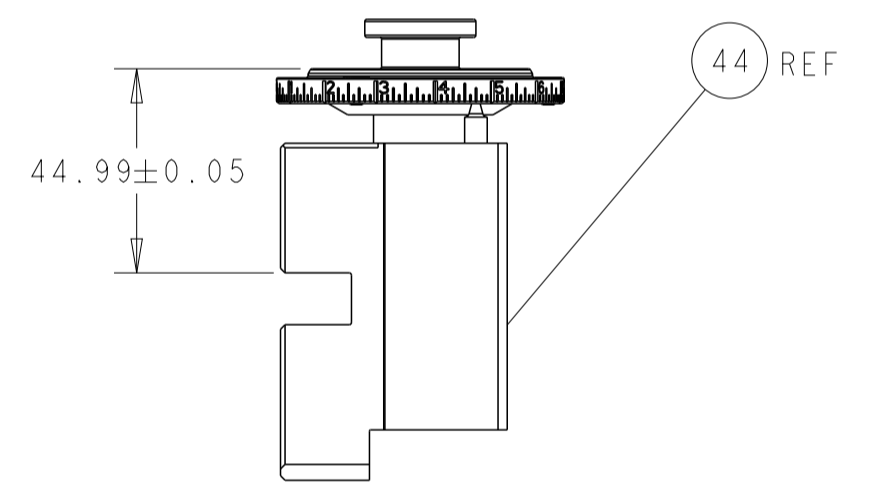

RAM SET-UP

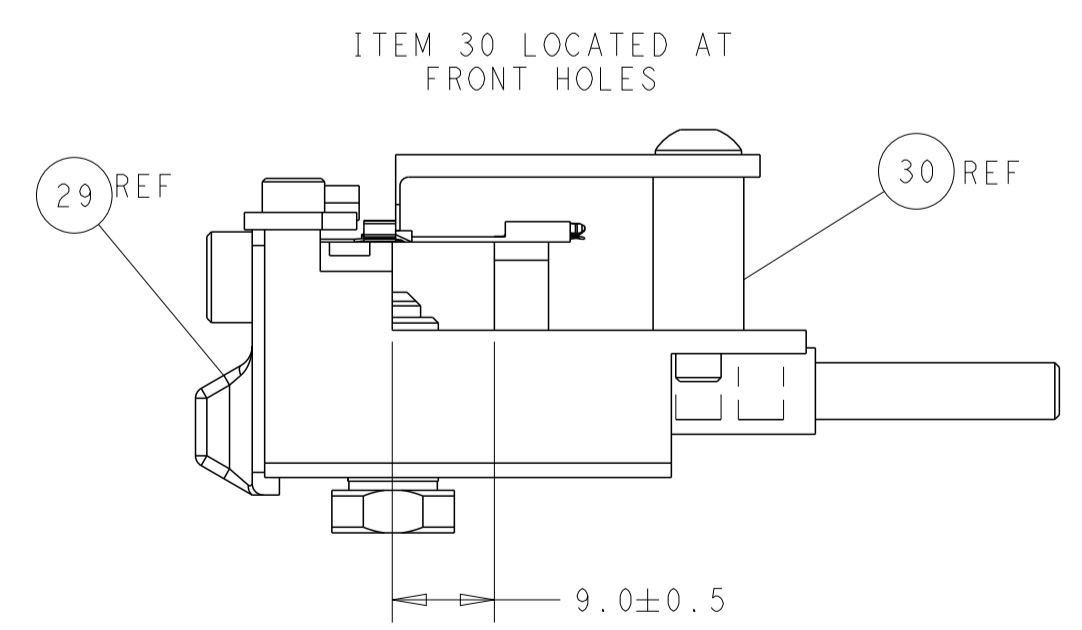

FEED TRACK POSITION GUIDE BY WIRE BARREL

CAM POSITIONS

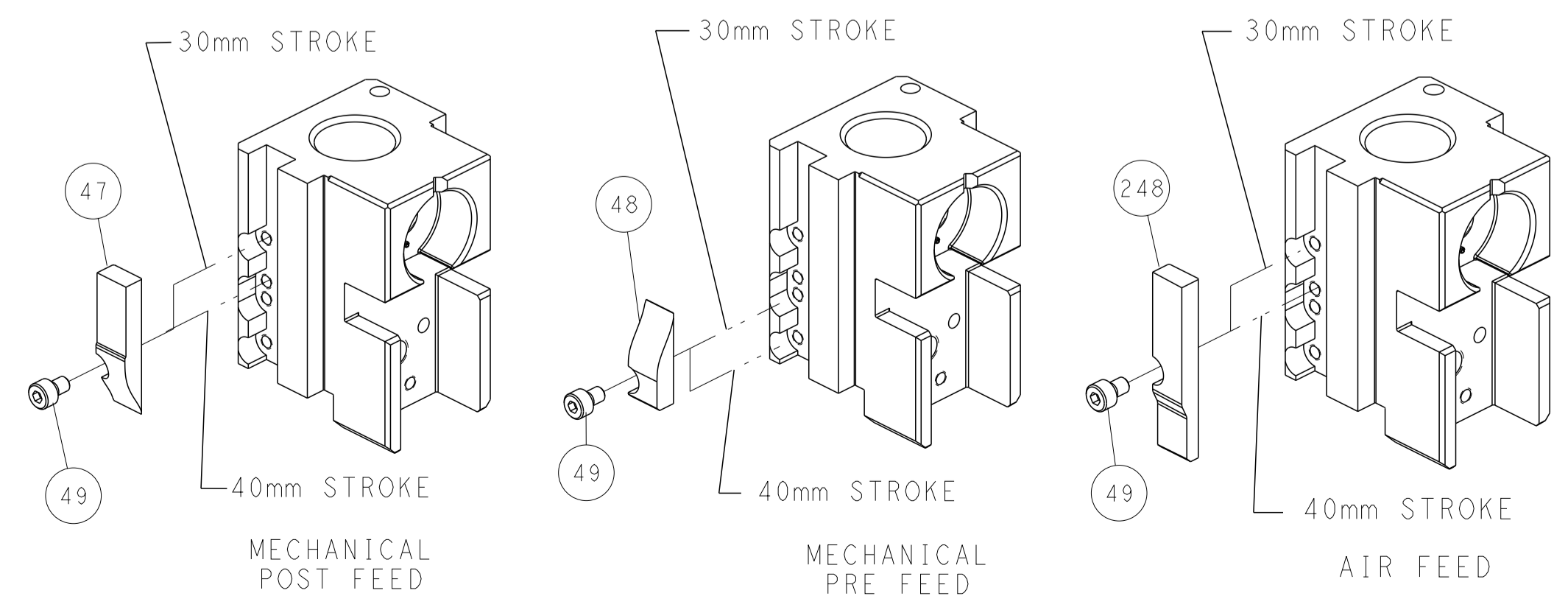

ATLANTIC VERSION
 Shown on sheets 1 of 4 & 2 of 4
 (Pacific version shown on sheets 3 of 4 & 4 of 4)

DIMENSIONS: mm 		TOLERANCES UNLESS OTHERWISE SPECIFIED: 0 PLC ± 1 PLC ± 2 PLC ± 3 PLC ± 4 PLC ± ANGLES ± FINISH		DWN Y. YIN 01APR2013 CHK G. BAILEY 01APR2013 APVD H. GUO 01APR2013 NAME Ocean Side Feed Applicator SIZE CAGE CODE DRAWING NO RESTRICTED TO A1 00779 C=2151516 CUSTOMER ACCESSIBLE PRODUCTION DRAWING SCALE 1:2 SHEET 2 OF 4 REV E	
MATERIAL:		WEIGHT:		DATE:	

PART NUMBER	REVISION	DESCRIPTION	FEED TYPE
2-2151516-1	E	FINE CRIMP HEIGHT ADJUST	MECHANICAL
2-2151516-2	E	FINE CRIMP HEIGHT ADJUST	PNEUMATIC
7-2151516-7	A	CRIMP TOOLING KIT	-

PACIFIC VERSION TERMINATOR
INTERFACE ADAPTER



APPLICATOR DATA		
CRIMP	SIZE	TYPE
WIRE	1.40 mm [.055]	F
INSUL	-	-
APPLICATOR INSTRUCTIONS 408-35042		

TERMINAL DATA: TE TERMINAL		TE CRIMP SPECIFICATION	
TERMINAL NAME: SOCKET CONTACT FOR IMM DIA PIN			
WIRE STRIP LENGTH 3.5-4.5 mm [1.38-.177 IN]		INSULATION DIAMETER RANGE Ø -	
TERMINAL APPLICATION SPECIFICATION	(A) 114-18972	-	-
	(B) 114-15132	-	-
TERMINALS APPLIED			
TE TERMINAL	TE TERMINAL	TE TERMINAL	TE TERMINAL
(A) 1564881-1	(A) 1-1564881-1	(A) 1564882-1	(A) 1-1564882-1
(B) 1801828-1	(B) 9-1801828-1	(B) 1801829-1	(B) 9-1801829-1

WIRE SIZE	CRIMP HEIGHT mm [INCH]	CRIMP HEIGHT REFERENCE SETTING
0.50mm2	0.86 +/- 0.03 [0.034 +/- .001]	6.4
0.35mm2	0.78 +/- 0.03 [0.031 +/- .001]	7.2

- ⚠ RECOMMENDED SPARE PARTS
- ⚠ REFER TO SUPPLIED INSTRUCTION SHEET FOR CLEANING, LUBRICATION AND STORAGE OF APPLICATOR.
- ⚠ TERMINAL LUBRICANT IS RECOMMENDED.
- ⚠ CRIMP HEIGHT REFERENCE SETTING WAS THE SETTING USED WHEN THE APPLICATOR WAS QUALIFIED AT THE FACTORY. ADJUSTMENT MAY BE NECESSARY WHEN RUNNING APPLICATOR IN THE FIELD.
- 5. UNLESS SPECIFIED OTHERWISE TORQUE VALUES SHALL BE USED PER DOCUMENT, 101-35000.

***WARNING**
ON INSTALLATION, SET WIRE DISC TO CRIMP HEIGHT REFERENCE SETTING FOR LARGEST WIRE SIZE. CRIMP HEIGHT REFERENCE SETTINGS GREATER THAN THE VALUE SHOWN MAY CAUSE DAMAGE TO THE CRIMP TOOLING. REFER TO THE INSTRUCTION SHEET FOR PROPER SETUP AND ADJUSTMENTS.

PACIFIC VERSION
Shown on sheets 3 of 4 & 4 of 4
(Atlantic version shown on sheets 1 of 4 & 2 of 4)

LOC	DIST	REVISIONS					
A	66	P	LTN	DESCRIPTION	DATE	DWN	APVD
		-	-	SEE SHEET 1	-	-	-

-	1	1	7-18023-7	SCR, SKT HD CAP M3 X 4.0	241
-	-	1	2119580-1	MECHANICAL FEED ASSEMBLY	239
-	1	-	2844940-1	AIR FEED MODULE	238
-	REF	REF	994970-2	COUNTER, MAGNETIC	164
-	1	-	2119641-2	FEED CAM, AIR FEED	151
-	1	1	2168083-8	SCR, SKT HD CAP, RoHS, M4 X 16	144
-	4	4	2168083-9	SCR, SKT HD CAP, RoHS, M4 X 20	143
-	-	1	2119653-2	FEED CAM, POST FEED	142
-	1	1	1-1803583-0	APPLICATOR BASIC ASSEMBLY, SF	141
-	1	1	1803516-1	RAM ASSEMBLY, SF PACIFIC	140
-	1	1	1-18028-2	WASHER, FLAT, REG M4	119
-	1	1	2119955-1	ASSY, LUBRICATOR, SIDE FEED	113
-	1	1	2844908-1	SCREW, LOCKING	99
-	1	1	2844907-1	POST, LOCKING	98
-	1	1	455888-5	SPACER, CRIMPER	82
-	2	2	2168083-1	SCR, SKT HD CAP, RoHS, M3 X 8.0	79
-	1	1	1633782-3	FENCE	78
-	1	1	5-547505-2	SPRING, COMPRESSION	77
-	1	1	854769-4	HOLDER, INS	74
-	1	1	1803607-3	DOCUMENTATION PACKAGE	71
-	1	1	2119740-1	TAG, IDENTIFICATION	67
-	2	2	2168078-1	SCREW, DRIVE, RH, RoHS, 2 x .188	66
-	1	1	5-18022-5	SCR, HEX HD CAP, M4 X 6.0	59
-	1	1	21028-2	PIN, SLOTTED SPRING .062 X .250	58
-	1	1	1338685-1	PAWL, FEED	56
-	2	2	2168083-8	SCR, SKT HD CAP, RoHS, M4 X 16	53
-	1	1	5018030-1	NUT, HEX, REG, RoHS, M3	52
-	1	1	811242-5	BUMPER, HOLD DOWN	51
-	1	1	690753-2	SPACER, TONKER	50
-	1	2	18023-9	SCR, SKT HD CAP M4 X 6.0	49
-	-	1	2119652-1	FEED CAM, PRE FEED	48
-	1	1	1803602-1	SCR, BHSC, RoHS (M8 X 25)	41
-	1	1	1-1752356-9	SUPPORT, TERMINAL	34
-	2	2	2079383-5	SCR, BHSC, RoHS (M4 X 20)	33
-	2	2	2-2844962-3	SPACER, CYLINDRICAL, STRIP GUIDE	30
-	1	1	2844992-1	ASSEMBLY, STRIP GUIDE	29
-	1	1	1-455888-0	SPACER, CRIMPER	28
-	1	1	1320928-2	STRIP GUIDE	24
-	1	1	2168083-2	SCR, SKT HD CAP, RoHS, M4 X 8.0	21
-	1	1	1-18028-2	WASHER, FLAT, REG M4	20
-	1	1	2119533-1	STRIPPER, SIDE FEED	19
-	1	1	2119806-1	INSERT, SHEAR	13
-	1	1	3-22280-3	SPRING, COMPRESSION	12
-	1	1	1-356885-4	STOP, SHEAR	11
-	1	1	2119805-1	SHEAR HOLDER, FRONT	10
-	1	1	1803095-1	FLOATING SHEAR, FRONT	9
-	1	1	6-1633139-9	ANVIL, COMBINATION	8
-	1	1	1-240641-4	SPACER	7
-	-	-	-	-	6
-	1	1	2119780-9	DEPRESSOR, SHEAR	5
-	-	-	-	-	4
-	-	-	-	-	3
-	-	-	-	-	2
-	1	1	1803125-6	CRIMPER, WIRE	1

DIMENSIONS:		TOLERANCES UNLESS OTHERWISE SPECIFIED:		DWG Y. YIN 01APR2013		TE Connectivity Harrisburg, PA 17105-3608	
mm		0 PLC ±		CHK G. BAILEY 01APR2013		NAME Ocean Side Feed Applicator	
1 PLC ±		2 PLC ±		APVD J. GUO 01APR2013		SIZE A1	
3 PLC ±		4 PLC ±		PRODUCT SPEC		CAGE CODE 00779	
5 PLC ±		ANGLES ±		APPLICATION SPEC		DRAWING NO 2151516	
FINISH		FINISH		WEIGHT		SCALE 1:2	
MATERIAL		MATERIAL		CUSTOMER ACCESSIBLE PRODUCTION DRAWING		SHEET 3 OF 4	

LOC	DIST	REVISIONS					
A	66	P	LTN	DESCRIPTION	DATE	DWN	APVD
		-		SEE SHEET 1			

FEED TYPE MECHANICAL

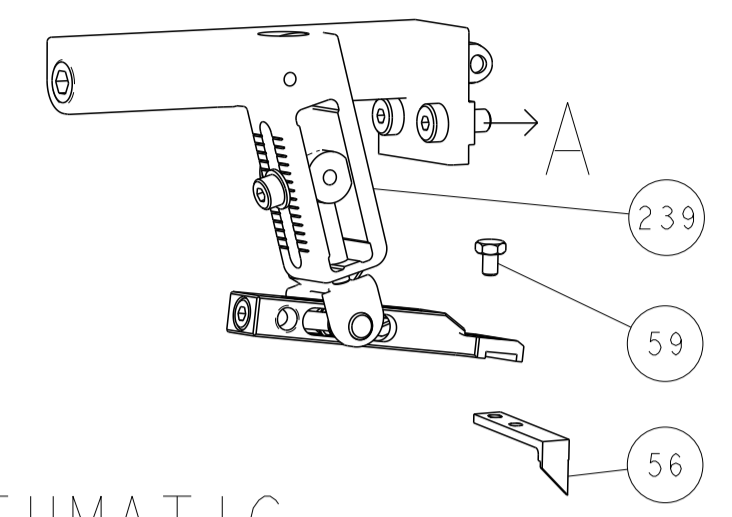

PNEUMATIC

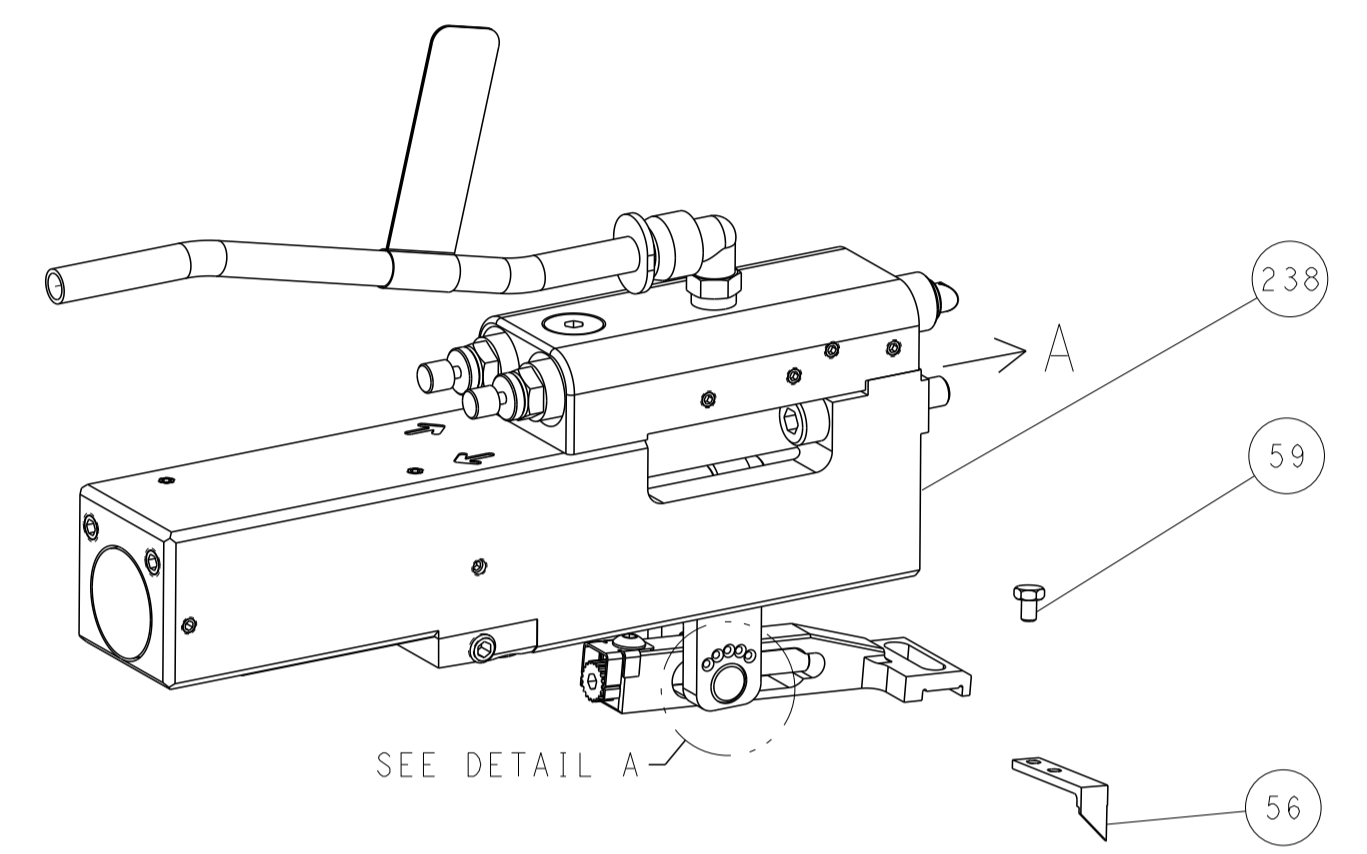

FEED SPRING SETTING POSITION (SHOWN FROM REAR SIDE)



DETAIL A

CAM POSITIONS

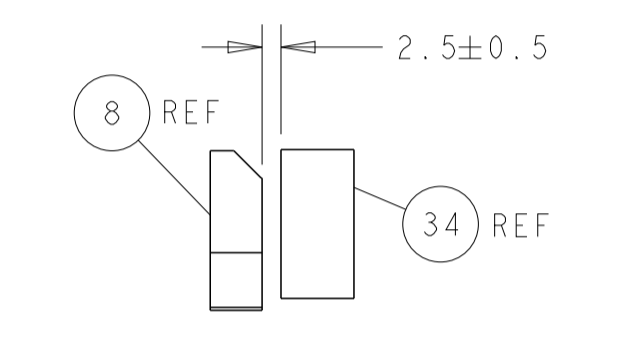
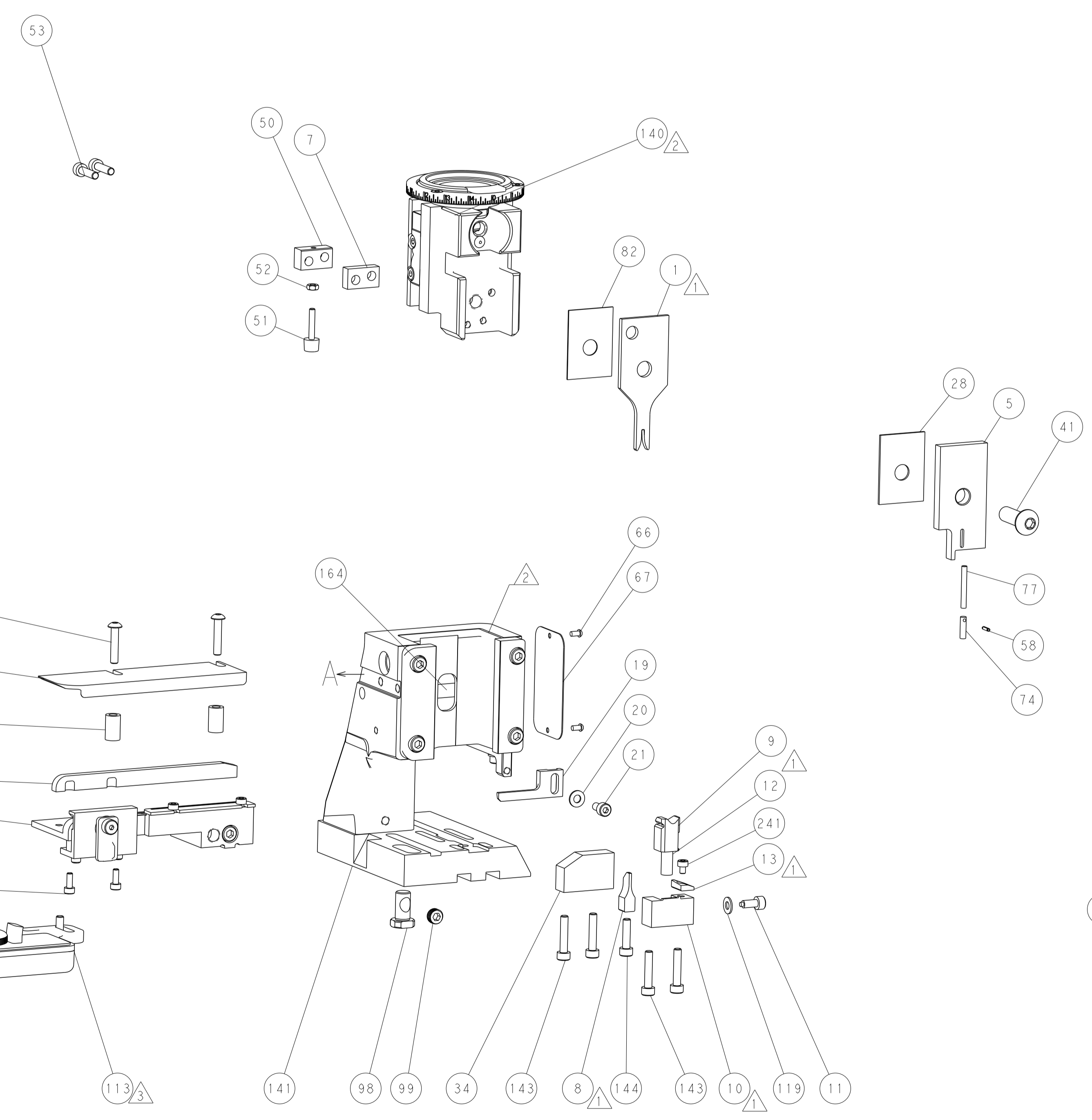
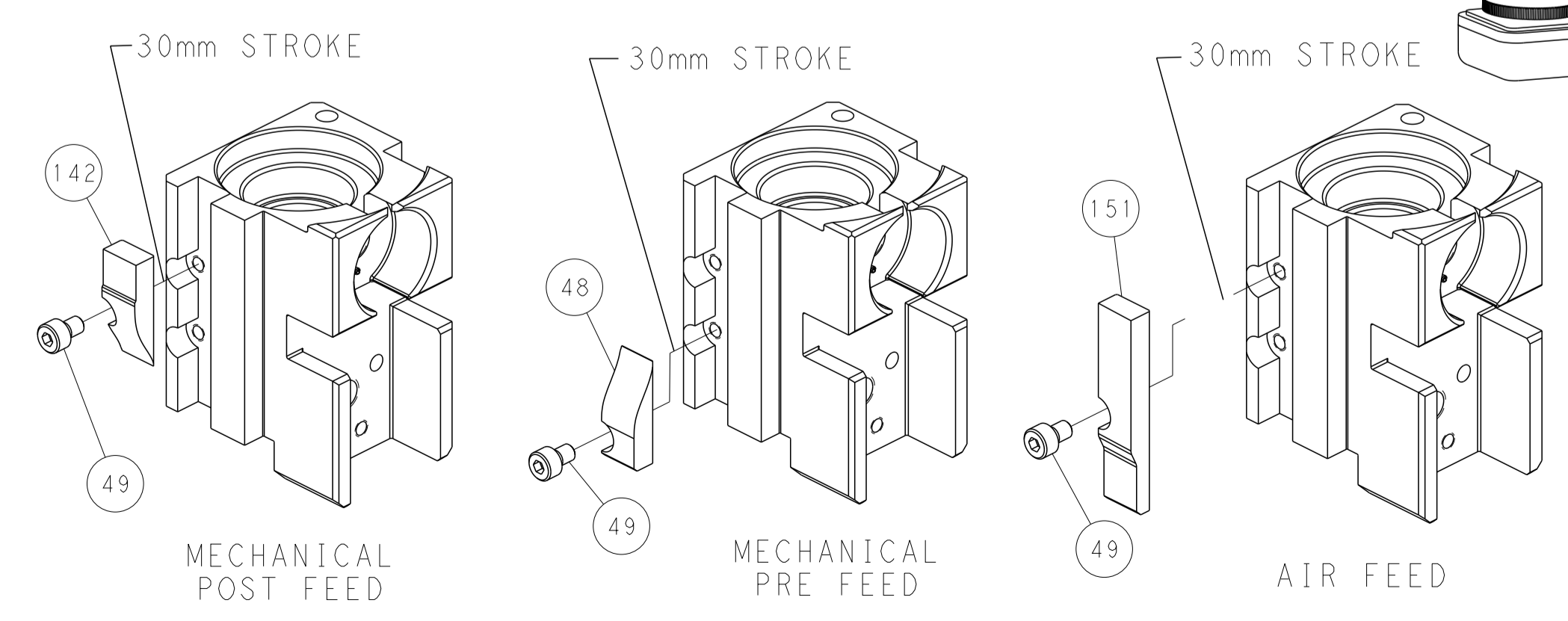

TERMINAL SUPPORT LOCATION

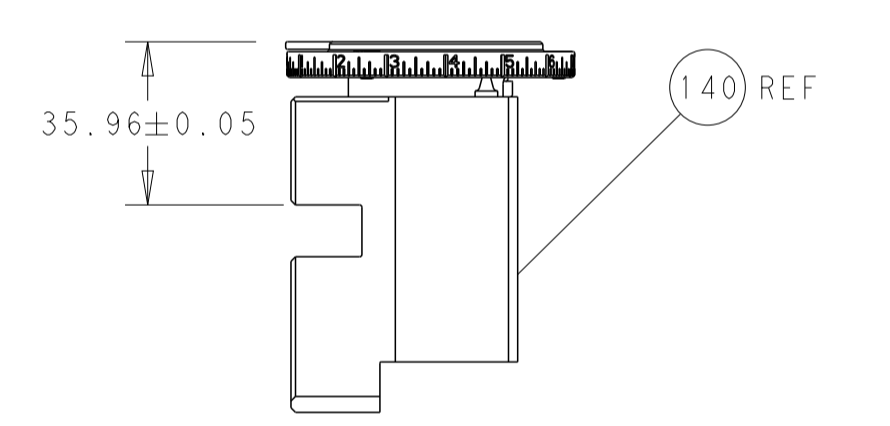

RAM SET-UP

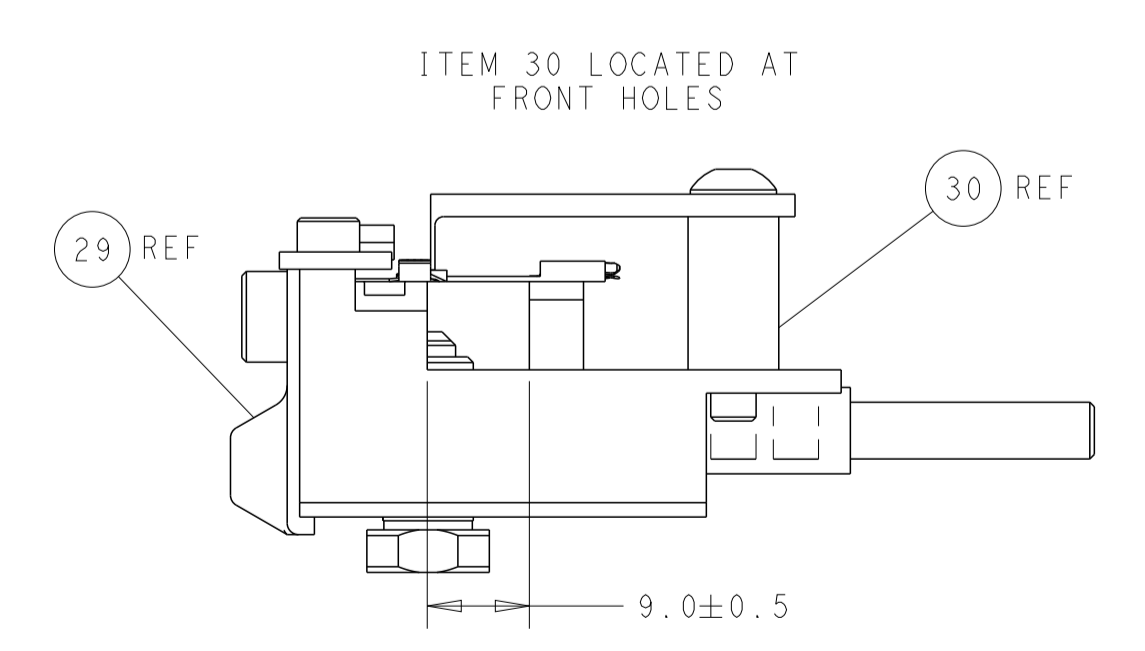

FEED TRACK POSITION GUIDE BY WIRE BARREL

PACIFIC VERSION
 Shown on sheets 3 of 4 & 4 of 4
 (Atlantic version shown on sheets 1 of 4 & 2 of 4)

<small>THIS DRAWING IS UNPUBLISHED. RELEASED FOR PUBLICATION. ALL RIGHTS RESERVED. THIS DRAWING IS THE PROPERTY OF TYCO ELECTRONICS CORPORATION. IT IS TO BE USED ONLY FOR THE PURPOSES AND IN THE QUANTITIES SPECIFIED IN THE ORDER. IT IS TO BE RETURNED TO TYCO ELECTRONICS CORPORATION UPON COMPLETION OF THE PROJECT.</small>		DWN: Y. YIN 01APR2013 CHK: G. BAILEY 01APR2013 APVD: H. GUO 01APR2013	NAME: TE Connectivity Harrisburg, PA 17105-3608
DIMENSIONS: mm TOLERANCES UNLESS OTHERWISE SPECIFIED: 0 PLC ± 1 PLC ± 2 PLC ± 3 PLC ± 4 PLC ± ANGLES FINISH ±	PRODUCT SPEC: - APPLICATION SPEC: - MATERIAL: - FINISH: -	SIZE: A1 CAGE CODE: 00779 DRAWING NO: 2151516 SCALE: 1:2 SHEET: 4 OF 4 REV: E	RESTRICTED TO: -