

TMC2300-MOTOR-EVAL Hardware Manual

Document Revision V1.0 • 2020-APR-23

The TMC2300-MOTOR-EVAL allows evaluation of the TMC2300-LA stepper motor driver in combination with a small built-in permanent magnet stepper motor and powered by just a single Li-Ion cell.

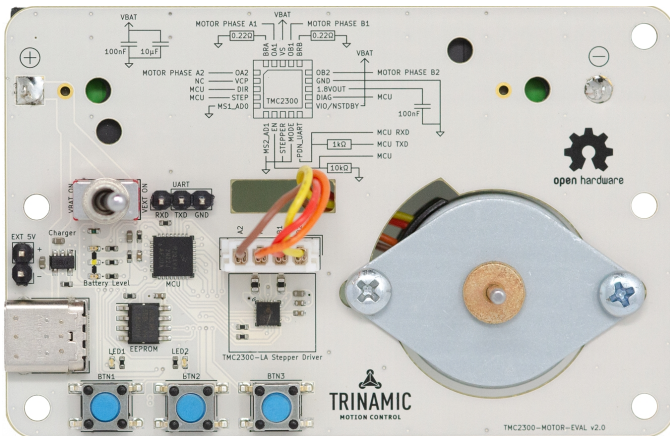

Features

- **2-phase** stepper motor up to 1.2A coil current (2A peak)
- Battery powered with onboard Li-Ion cell, max. external supply 4.5V
- Li-Ion cell charger via USB-C
- **UART** for access to TMCL-IDE, configuration, control, and programming
- **StealthChop2™** silent motor operation
- **Stall detection** StallGuard4™ in StealthChop mode
- **CoolStep™** smart current control

Applications

- IoT & Handheld devices
- Battery operated equipment
- Printers, POS
- Miniature 3D Printers
- Toys
- Office and home automation
- CCTV, Security
- HVAC
- Mobile medical devices

Simplified Block Diagram

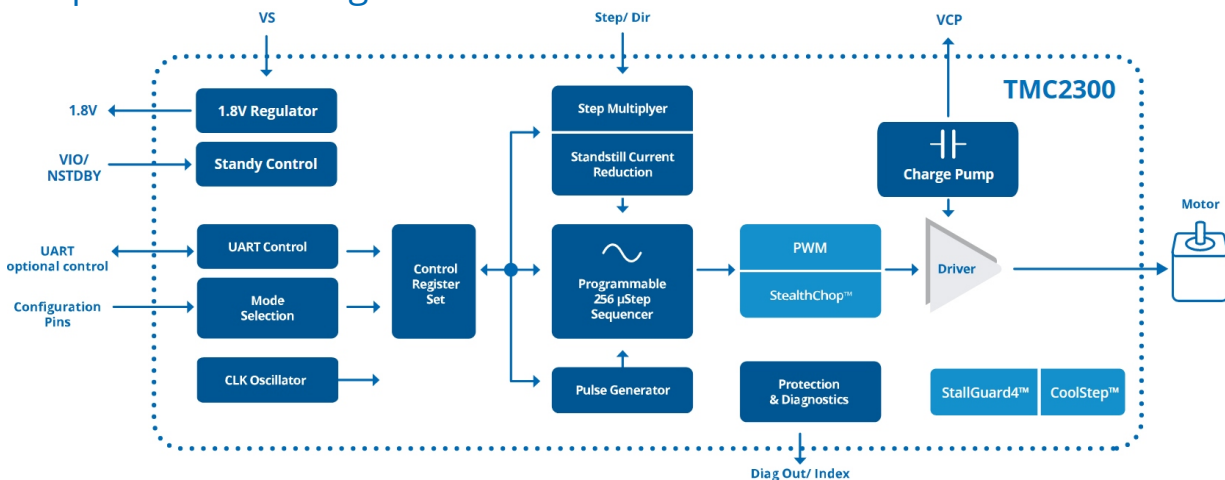

Contents

1 Getting Started	3
1.1 First Start-Up	4
2 Firmware & TMCL Information	5
3 Hardware Information	6
3.1 Onboard Connectors	6
3.2 Onboard Switches and Buttons	7
3.3 Onboard LEDs	7
3.4 Battery Holder	8
3.5 Schematic Drawings	9
4 Revision History	11
4.1 Document Revision	11



1 Getting Started

You need

- Your TMC2300-MOTOR-EVAL.
- Own stepper motor with 4-pin ST-PH connector or use the integrated motor ([Goot Motor PM25S-048-413](#))
- Li-Ion battery of type 18650 , **not included in the kit**
- USB-C cable (just for charging the battery)
- USB-2-UART cable (3.3V TTL) to connect to on-board UART (RX/TX) header
- Latest [TMCL-IDE V3.x](#)

Precautions

- Do not mix up connections or short-circuit pins.
- Avoid bundling I/O wires with motor wires.
- Do not exceed the maximum rated supply voltage! Especially when using an external 5V supply at the +5V external supply header.
- **Do not use other battery types than Li-Ion with the board!**
- **Do only use Li-Ion batteries with integrated protection!**
- The Li-Ion cell should be properly charged.
- Do not connect or disconnect the motor while powered!
- **START WITH POWER SUPPLY OFF!**

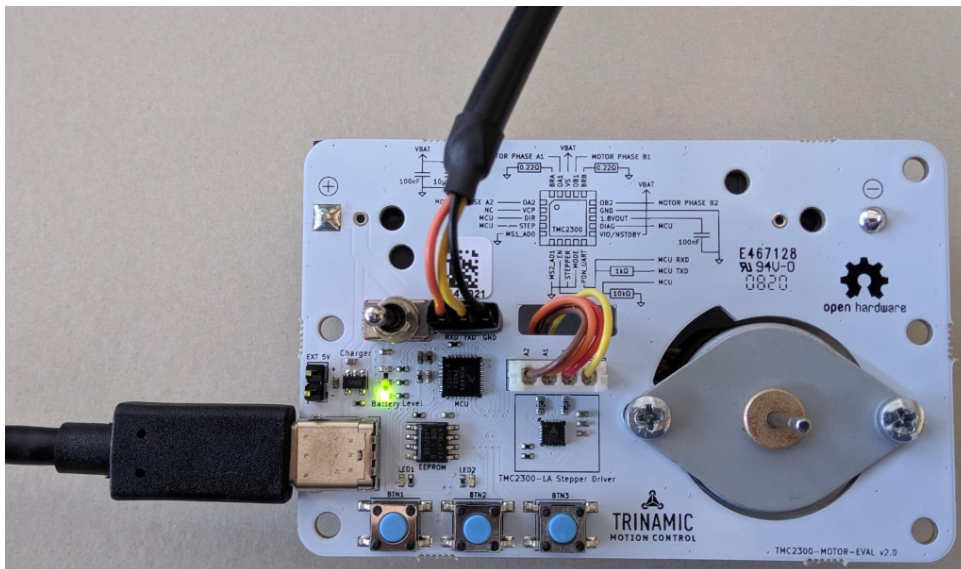

Figure 1: TMC2300-MOTOR-EVAL setup with USB-C and UART interface connected



1.1 First Start-Up

1. First of all, you will need a PC with Windows (at least Windows 7) and the TMCL-IDE 3.x installed on it. If you do not have the TMCL-IDE installed on your PC then please download it from the TMCL-IDE product page of [Trinamic's website](#) and install it on your PC.
2. Please also ensure that your TMC2300-MOTOR-EVAL is properly connected and the power supply is properly selected. Please see the TMC2300-MOTOR-EVAL hardware manual for instructions on how to do this. **Do not connect or disconnect a motor to or from the module while the module is powered!**
3. Then, please start up the TMCL-IDE. After that you can connect your TMC2300-MOTOR-EVAL via the USB-2-UART interface and switch on the power supply (while the TMCL-IDE is running on your PC).
4. When the TMC2300-MOTOR-EVAL is connected properly it will be recognized by the TMCL-IDE in the connected devices tree so that it can be used. Verify that the TMC2300-MOTOR-EVAL is using the latest firmware version. The firmware version is shown in the connected device tree behind the module's name. Check the module page on the [Trinamic website](#) for new firmware versions.

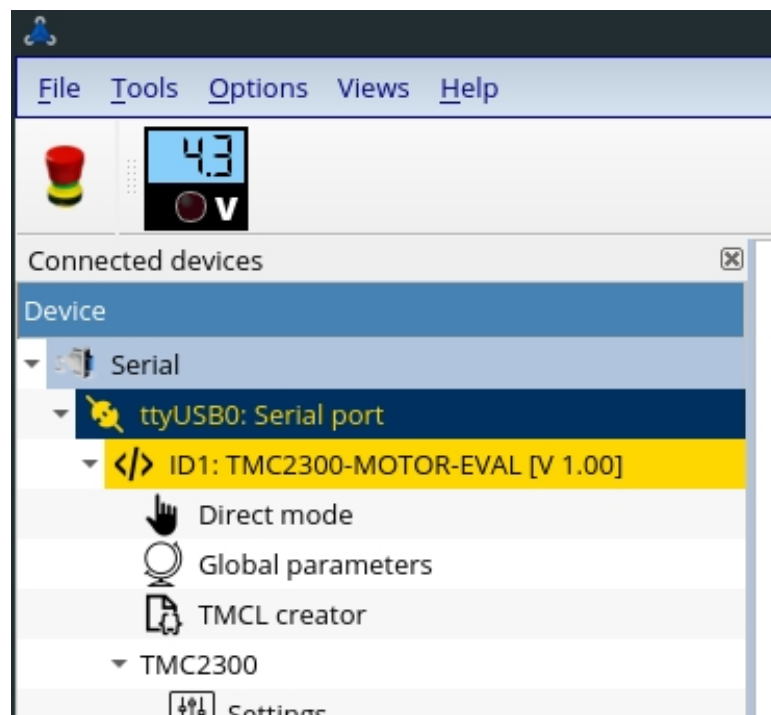

Figure 2: Firmware Version

5. The TMCL-IDE needs room to show all important information and to provide a good overview. Therefore, arrange the main window related to your needs. We recommend using full screen.



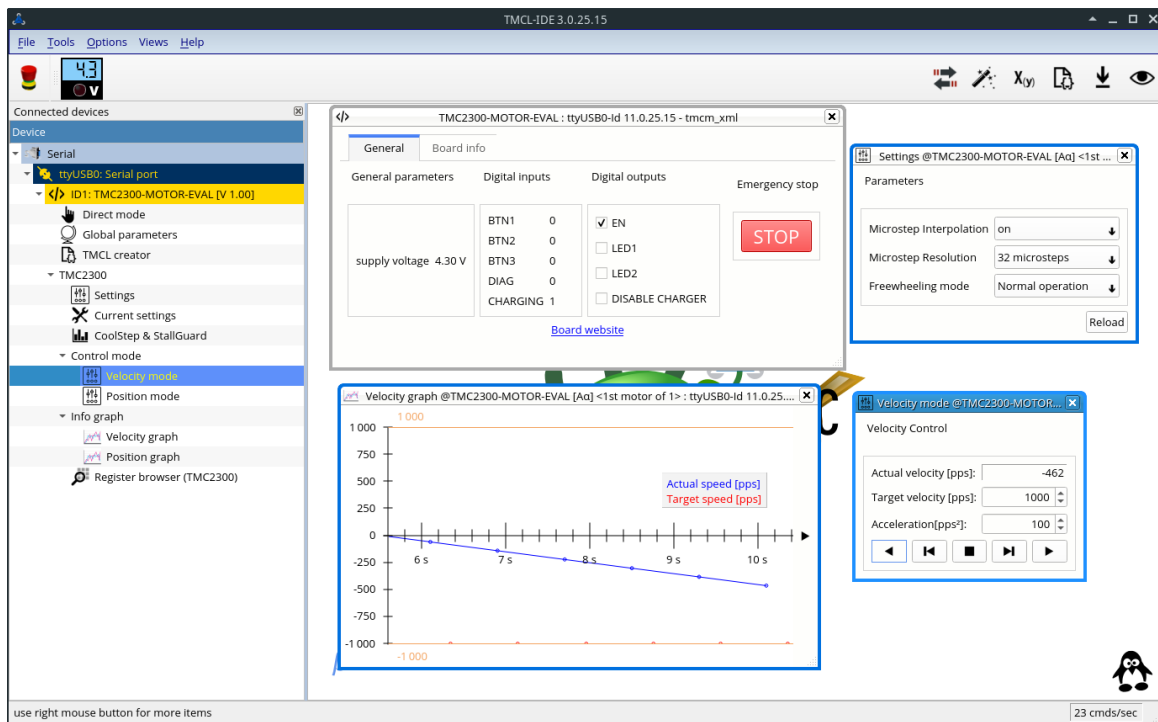

Figure 3: TMCL-IDE full view

2 Firmware & TMCL Information

The TMC2300-MOTOR-EVAL uses a TMCL-based firmware stack for communication.

TMCL scripts can be executed from the TMCL-IDE or can be stored on the on-board EEPROM and used in autostart mode.

More information on TMCL and its commands is available in the TMC2300-MOTOR-EVAL TMCL firmware manual available on the [TRINAMIC Evaluation Kit Homepage](http://www.trinamic.com)



3 Hardware Information

All design files for our evaluation boards are available for free. We offer the original ECAD files, Gerber data, the BOM, and PDF copies. For the TMC2300-MOTOR-EVAL the CAD files are available in KiCAD format. Please check schematics for Jumper settings and input/output connector description.

The files can be downloaded from the evaluation boards' website directly at our homepage: [TRINAMIC Eval Kit homepage](#).

Note If files are missing on the website or something is wrong please send us a note.

3.1 Onboard Connectors

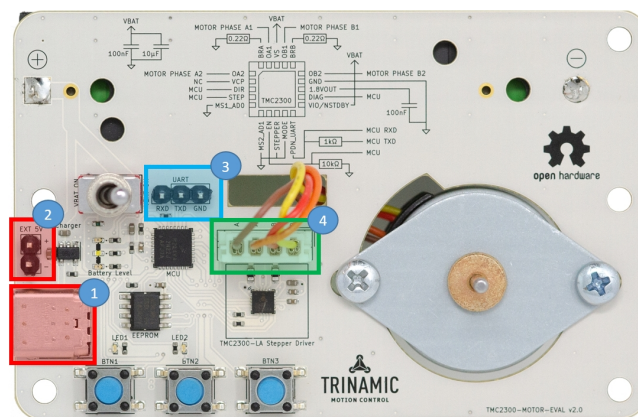

Figure 4: Top side connectors

The following connectors are available on the TMC2300-MOTOR-EVAL.

1. **Battery charger connector:** This is a USB-C connector. Connect a 5V charger to it to allow charging
2. **External supply header:** This is an additional supply option. An external stabilized supply with absolute max. level of 5V can be connected here. This supply is not used for charging. This supply directly connects to the driver and MCU (the MCU is a 5V-compatible MCU).
3. **UART communication header:** This is a standard 2.54mm pitch header with direct connection to the MCU. It is required for serial communication with the TMCL-IDE on a PC. Connect a USB-2-UART converter to it. When using a 5V external supply a 5V-capable USB-2-UART converter is suggested. Most 3.3V type USB-2-UART converters work as well when using the Li-Ion cell for supply.
4. **Stepper motor connector:** This is a 4-pin JST PH series connector and connects the TMC2300-LA motor driver outputs to the motor phases. By default the onboard permanent magnet stepper motor is connected. An own external motor can be connected as well. **Plug/unplug the motor only when the module is not powered!**

All connectors have a pin 1 mark and signal labels at each pin.



3.2 Onboard Switches and Buttons

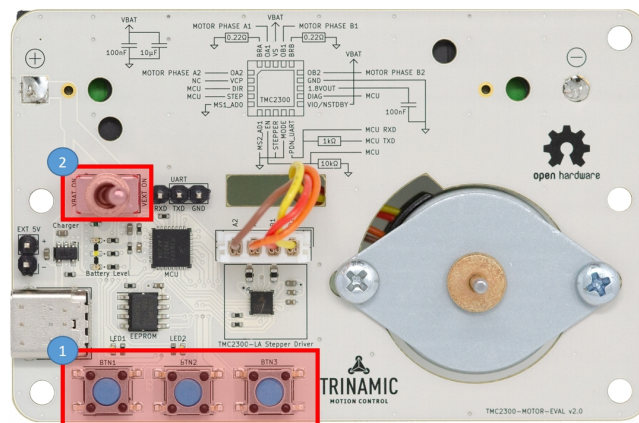

Figure 5: Top side Switches and Buttons

1. **Push Buttons:** Three standard push buttons are available for use with own TMCL scripts to react on user interaction, e.g., direction change or speed change. The function depends on the user's TMCL script. The corresponding IOs are described in the firmware manuals.
2. **Power Switch:** This is a 2-way switch to switch the module on/off and select the power supply source.
 - When the position is on VEXT_ON as shown in the picture the external supply from the 2-pin header is chosen. If no supply is connected to EXT_5V the TMC2300-MOTOR-EVAL is not powered. In this position the charger and charging circuit are also active when USB-C is connected. The Li-Ion cell will be charged but the LED indicators for the battery level / charge status are not active.
 - When the position is on VBAT_ON the onboard battery supply is chosen as supply. Motor supply and digital supply are derived from the onboard Li-Ion cell.

3.3 Onboard LEDs

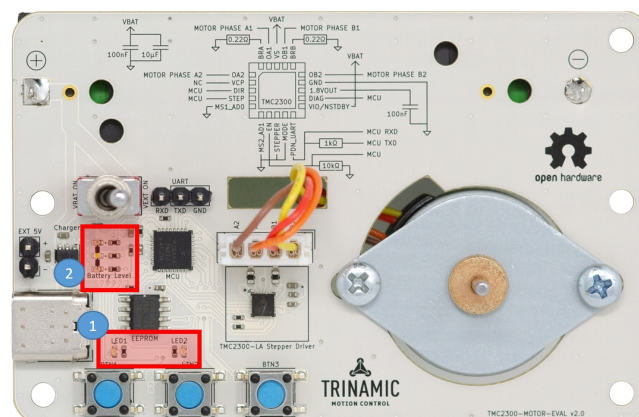

Figure 6: Top side LEDs



1. **User LEDs:** There are 2 LEDs (blue color) available for use with own TMCL scripts to react on user interaction or indicate certain conditions. The corresponding IOs are described in the firmware manuals.
2. **Charge Level / Status LEDs:** There are 3 LEDs of different color to indicate the charger state when a 5V USB-C charger is connected and the Li-Ion cell's charge level when no USB-C is connected. When charging the green LED is blinking. When not charging the green LEDs are permanently on and are roughly indicating the charge level: green = good, yellow = middle, red = need to charge.

3.4 Battery Holder

The battery holder is assembled on the bottom side. A 18650 type/size battery fits into. A 2A fuse is used to limit the maximum current draw from the battery.

Note

Please check polarity of the battery before insertion! The proper polarity is indicated on the bottom side silkscreen and inside the battery cage itself.

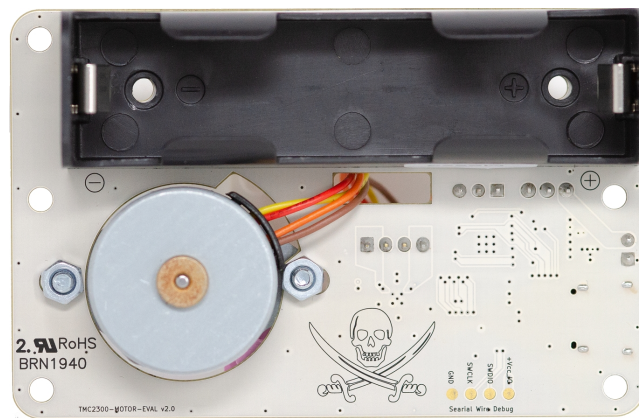

Figure 7: Battery holder on bottom side



Figure 8: Example Li-Ion battery of type/size 18650, a type with integrated protection is highly recommended



3.5 Schematic Drawings

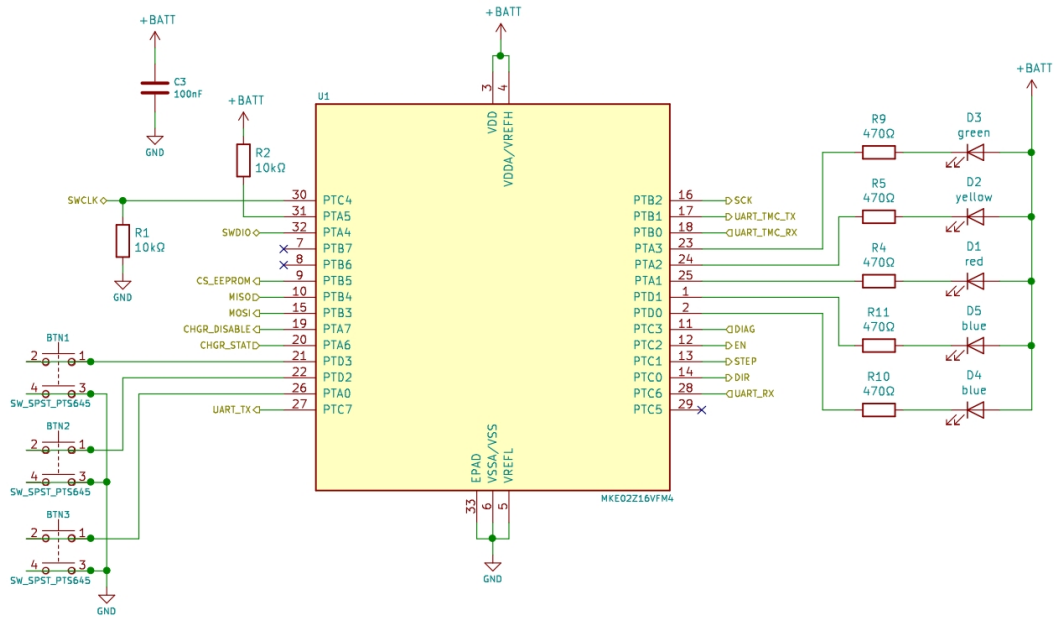

Figure 9: MCU circuit and connections

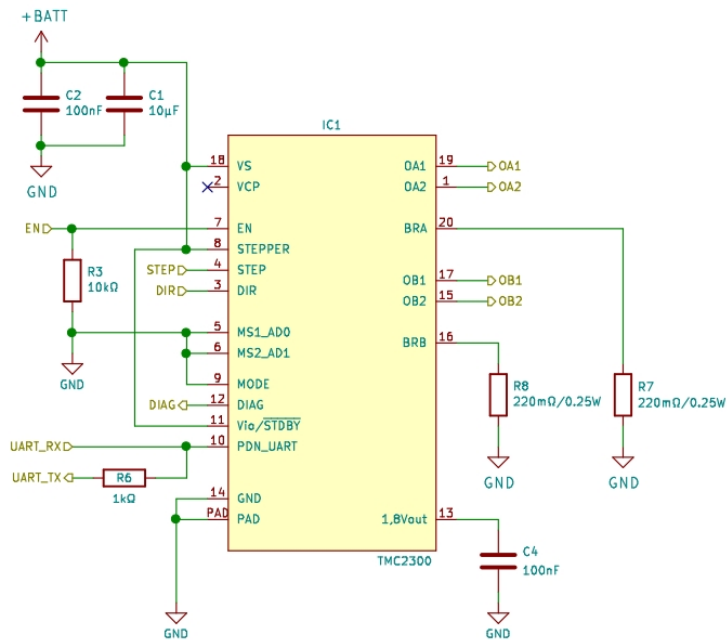

Figure 10: TMC2300-LA motor driver circuit



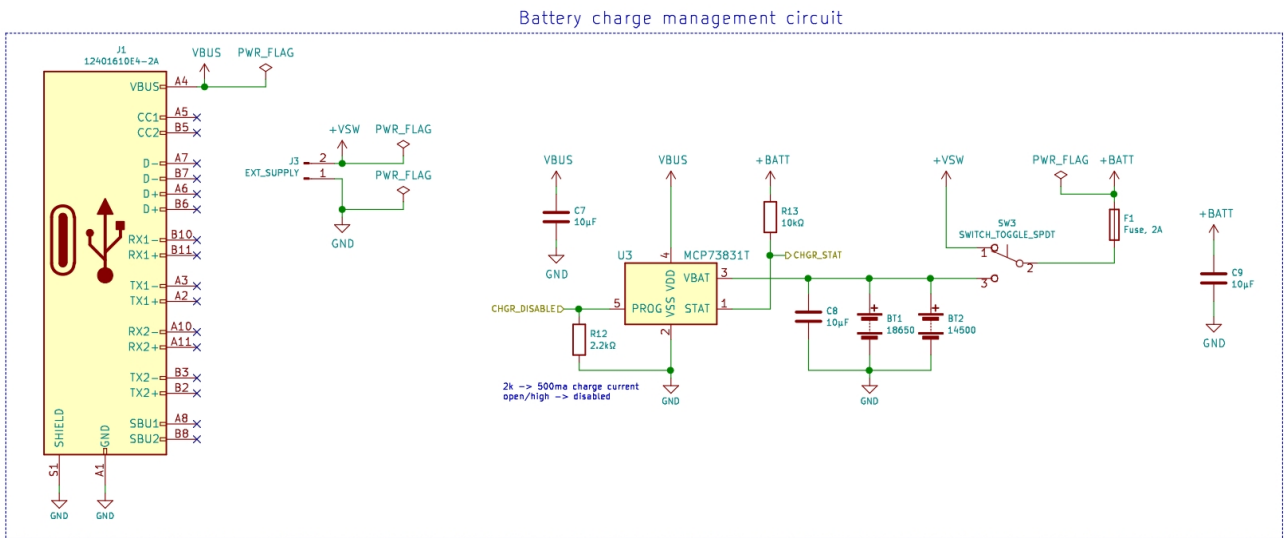

Figure 11: Battery charger circuit

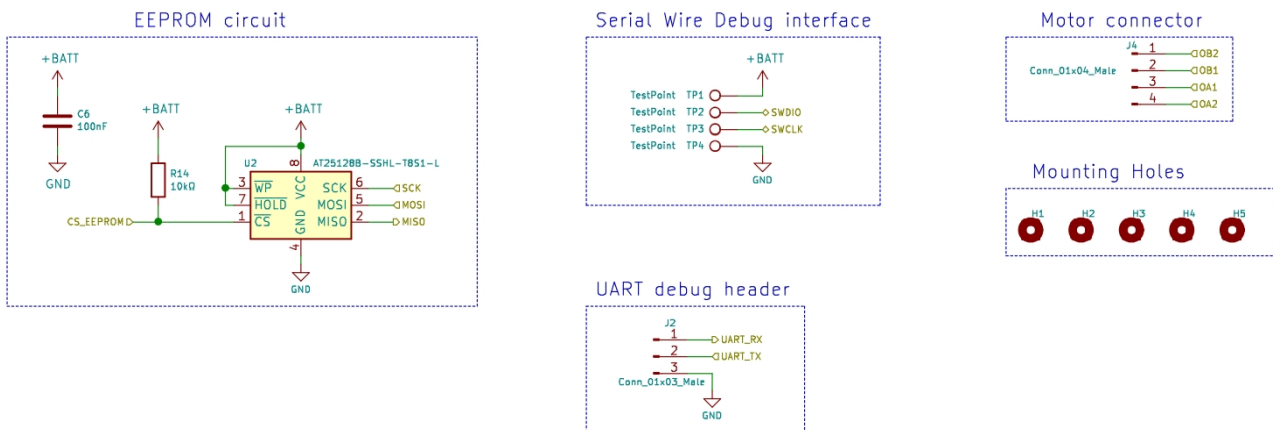

Figure 12: Miscellaneous



4 Revision History

4.1 Document Revision

Version	Date	Author	Description
1.0	2020-04-23	SK/SW	Initial release.

Table 1: Document Revision

