

LOC	DIST	REVISIONS			
P	LTR	DESCRIPTION	DATE	DWN	APVD
AP	-	D5	REV. BY ECO-18-010173	27JUNE2018	HC WLS
		D6	REVISED PER ECR-20-009164	22JULY2020	MK DH

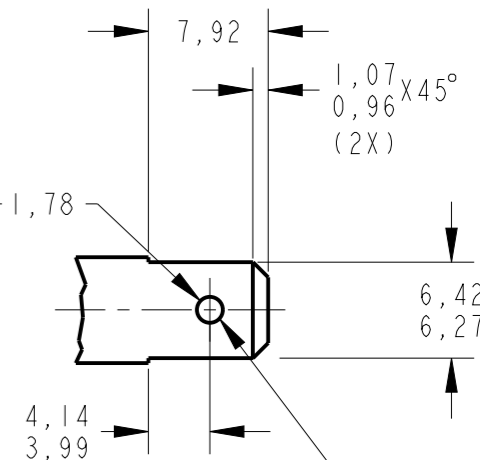
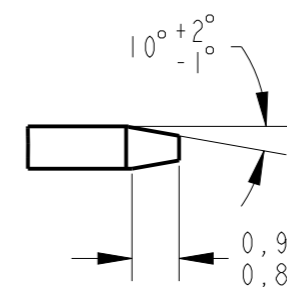
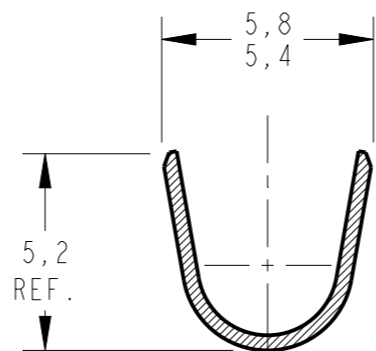
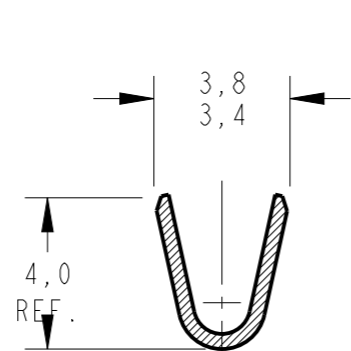
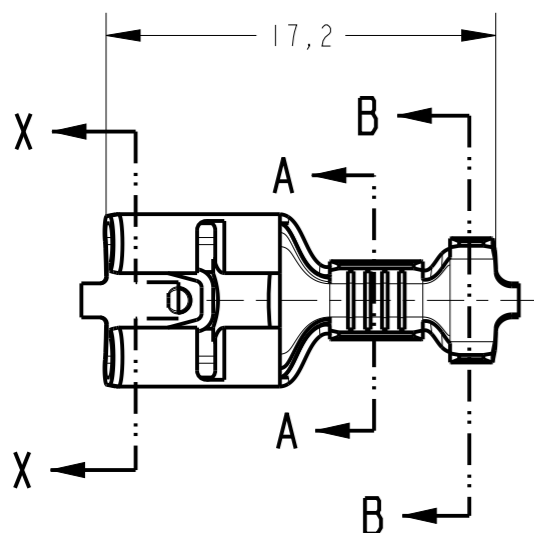

CHANFER 0,1MAX. PERMITTED

TEST TAB
 BR-6-058-1
 MATERIAL: AÇO RÁPIDO

SEE DETAIL Y

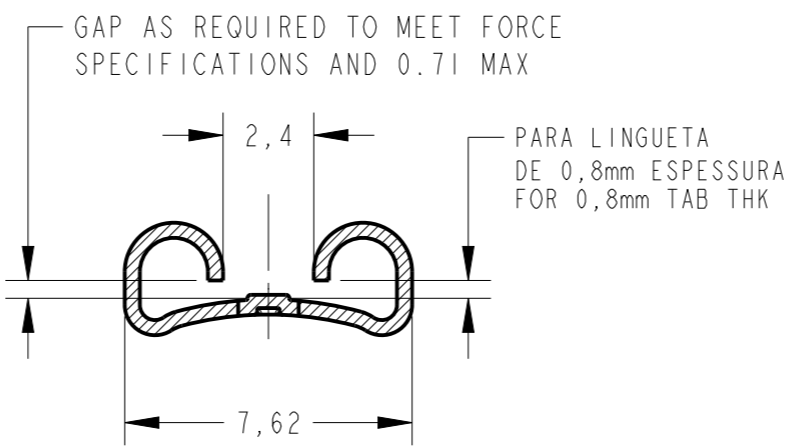
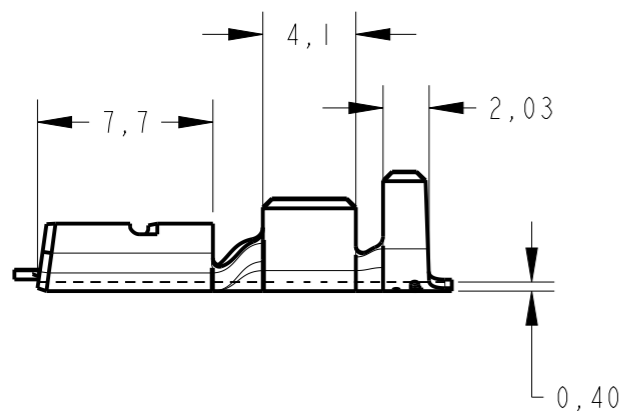
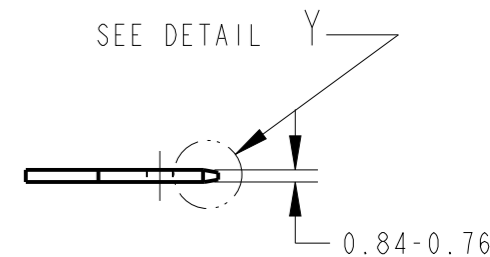

SECTION X-X SCALE 5:1

0.84-0.76	ESTANHADO / TIN PLATED	LATÃO / BRASS	444335 -4
0.84-0.76	—	LATÃO / BRASS	444335 -3
0.84-0.76	ESTANHADO / TIN PLATED	LATÃO / BRASS	444335 -2
0.84-0.76	—	LATÃO / BRASS	444335 -1
MATING TAB THK.	FINISH	MATERIAL	PART NUMBER

INS. RANGE	WIRE RANGE
∅ 3,0-4,3mm	1,0-2,5mm ²

THIS DRAWING IS A CONTROLLED DOCUMENT.

DIMENSIONS: mm

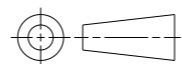

TOLERANCES UNLESS OTHERWISE SPECIFIED:
 0 PLC ±0,3
 1 PLC ±
 2 PLC ±
 3 PLC ±
 4 PLC ±
 ANGLES ±1°

MATERIAL - FINISH -

DWN NCLAPRESA 12JUL2012
 CHK JRGOLDSCHMIDT 12JUL2012
 APVD DAOLIVEIRA 12JUL2012

PRODUCT SPEC 108-37034
 APPLICATION SPEC -

WEIGHT -

STE TE Connectivity

NAME: **TERMINAL FASTON 6,35 RECEPT**

SIZE	CAGE CODE	DRAWING NO	RESTRICTED TO
A3	00779	444335	-

Customer Drawing SCALE 3:1 SHEET 1 OF 1 REV D6

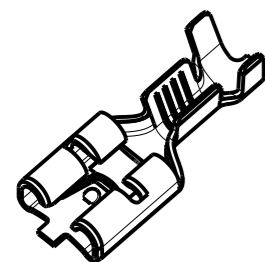

PERSPECTIVE VIEW SCALE 2:1

PART NUMBER	1° INSERÇÃO MÁX. (N)	1° EXTRAÇÃO MÍN. (N)	10° EXTRAÇÃO MÍN. (N)
444335 -1	40	50	20
444335 -2	40	50	20
444335 -3	40	70	20
444335 -4	40	70	20