

Main Product Characteristics

$V_{(BR)DSS}$	20V	-20V
$R_{DS(ON)}$	300m Ω	600m Ω
I_D	800mA	-400mA

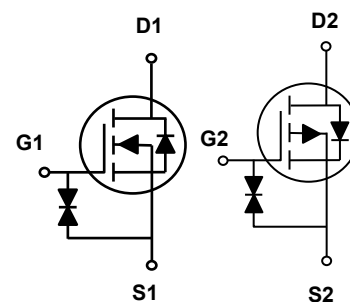

SOT-563



Schematic Diagram

Features and Benefits

- Advanced MOSFET process technology
- Ideal for notebook, load switch, networking and hand-held devices
- Low on-resistance with low gate charge
- Fast switching and reverse body recovery



Description

The SSF7120 utilizes the latest techniques to achieve high cell density and low on-resistance. These features make this device extremely efficient and reliable for use in high efficiency switch mode power supply and a wide variety of other applications.

Absolute Maximum Ratings ($T_C=25^\circ\text{C}$ unless otherwise specified)

Parameter	Symbol	Value		Unit
Drain-Source Voltage	V_{DS}	20	-20	V
Gate-Source Voltage ⁴	V_{GS}	± 12	± 12	V
Drain Current – Continuous ($T_C=25^\circ\text{C}$)	I_D	800	-400	mA
Drain Current – Continuous ($T_C=100^\circ\text{C}$)		510	-250	mA
Drain Current – Pulsed ¹	I_{DM}	3.2	-1.6	A
Power Dissipation ($T_C=25^\circ\text{C}$)	P_D	312		mW
Power Dissipation – Derate above 25°C	P_D	2.5		mW/ $^\circ\text{C}$
Storage Temperature Range	T_{STG}	-55 to +150		$^\circ\text{C}$
Operating Junction Temperature Range	T_J	-55 to +150		$^\circ\text{C}$

Thermal Characteristics

Parameter	Symbol	Typ.	Max.	Unit
Thermal Resistance Junction to Ambient	$R_{\theta JA}$	---	400	$^\circ\text{C}/\text{W}$

N-Channel Electrical Characteristics (T_J=25°C unless otherwise specified)

Parameter	Symbol	Conditions	Min.	Typ.	Max.	Unit
Off Characteristics						
Drain-Source Breakdown Voltage	BV _{DSS}	V _{GS} =0V, I _D =250μA	20	---	---	V
BV _{DSS} Temperature Coefficient	ΔBV _{DSS} /ΔT _J	Reference to 25°C, I _D =1mA	---	-0.01	---	V/°C
Drain-Source Leakage Current	I _{DSS}	V _{DS} =20V, V _{GS} =0V, T _J =25°C	---	---	1	μA
		V _{DS} =16V, V _{GS} =0V, T _J =125°C	---	---	10	μA
Gate-Source Leakage Current	I _{GSS}	V _{GS} =±8V, V _{DS} =0V	---	---	±20	μA
On Characteristics						
Static Drain-Source On-Resistance	R _{DS(ON)}	V _{GS} =4.5V, I _D =0.5A	---	200	300	mΩ
		V _{GS} =2.5V, I _D =0.4A	---	235	400	
		V _{GS} =1.8V, I _D =0.2A	---	295	550	
		V _{GS} =1.5V, I _D =0.1A	---	365	800	
		V _{GS} =1.2V, I _D =0.1A	---	600	-	
Gate Threshold Voltage	V _{GS(th)}	V _{GS} =V _{DS} , I _D =250μA	0.3	0.6	1.0	V
V _{GS(th)} Temperature Coefficient	ΔV _{GS(th)}		---	3	---	mV/°C
Dynamic and Switching Characteristics						
Total Gate Charge ^{2, 3}	Q _g	V _{DS} =10V, V _{GS} =4.5V, I _D =0.5A	---	1	2	nC
Gate-Source Charge ^{2, 3}	Q _{gs}		---	0.26	0.5	
Gate-Drain Charge ^{2, 3}	Q _{gd}		---	0.2	0.4	
Turn-On Delay Time ^{2, 3}	T _{d(on)}	V _{DD} =10V, V _{GS} =4.5V, R _G =10Ω, I _D =0.5A	---	5	10	nS
Rise Time ^{2, 3}	T _r		---	3.5	7	
Turn-Off Delay Time ^{2, 3}	T _{d(off)}		---	14	28	
Fall Time ^{2, 3}	T _f		---	6	12	
Input Capacitance	C _{iss}	V _{DS} =10V, V _{GS} =0V, F=1MHz	---	38.2	75	pF
Output Capacitance	C _{oss}		---	14.4	28	
Reverse Transfer Capacitance	C _{rss}		---	6	12	
Drain-Source Diode Characteristics and Maximum Ratings						
Continuous Source Current	I _S	V _G =V _D =0V, Force Current	---	---	0.8	A
Pulsed Source Current	I _{SM}		---	---	1.6	A
Diode Forward Voltage	V _{SD}	V _{GS} =0V, I _S =-0.2A, T _J =25°C	---	---	1	V

P-Channel Electrical Characteristics (T_J=25°C unless otherwise specified)

Parameter	Symbol	Conditions	Min.	Typ.	Max.	Unit
Off Characteristics						
Drain-Source Breakdown Voltage	BV _{DSS}	V _{GS} =0V, I _D =-250μA	-20	---	---	V
BV _{DSS} Temperature Coefficient	ΔBV _{DSS} /ΔT _J	Reference to 25°C, I _D =-1mA	---	-0.01	---	V/°C
Drain-Source Leakage Current	I _{DSS}	V _{DS} =-20V, V _{GS} =0V, T _J =25°C	---	---	-1	μA
		V _{DS} =-16V, V _{GS} =0V, T _J =125°C	---	---	-10	μA
Gate-Source Leakage Current	I _{GSS}	V _{GS} =±8V, V _{DS} =0V	---	---	±20	μA
On Characteristics						
Static Drain-Source On-Resistance	R _{DS(ON)}	V _{GS} =-4.5V, I _D =-0.3A	---	440	600	mΩ
		V _{GS} =-2.5V, I _D =-0.2A	---	610	850	
		V _{GS} =-1.8V, I _D =-0.1A	---	810	1200	
		V _{GS} =-1.5V, I _D =-0.1A	---	1020	1600	
		V _{GS} =-1.2V, I _D =-0.1A	---	1800	---	
Gate Threshold Voltage	V _{GS(th)}	V _{GS} =V _{DS} , I _D =-250μA	-0.3	-0.6	-1.0	V
V _{GS(th)} Temperature Coefficient	ΔV _{GS(th)}		---	3	---	mV/°C
Dynamic and Switching Characteristics						
Total Gate Charge ^{2, 3}	Q _g	V _{DS} =-10V, V _{GS} =-4.5V, I _D =-0.2A	---	1	2	nC
Gate-Source Charge ^{2, 3}	Q _{gs}		---	0.28	0.5	
Gate-Drain Charge ^{2, 3}	Q _{gd}		---	0.18	0.4	
Turn-On Delay Time ^{2, 3}	T _{d(on)}	V _{DD} =-10V, V _{GS} =-4.5V, R _G =10Ω I _D =-0.2A	---	8	16	nS
Rise Time ^{2, 3}	T _r		---	5.2	10	
Turn-Off Delay Time ^{2, 3}	T _{d(off)}		---	30	60	
Fall Time ^{2, 3}	T _f		---	18	36	
Input Capacitance	C _{iss}	V _{DS} =-10V, V _{GS} =0V, F=1MHz	---	40	78	pF
Output Capacitance	C _{oss}		---	15	30	
Reverse Transfer Capacitance	C _{rss}		---	6.5	13	
Drain-Source Diode Characteristics and Maximum Ratings						
Continuous Source Current	I _S	V _G =V _D =0V, Force Current	---	---	-0.4	A
Pulsed Source Current	I _{SM}		---	---	-0.8	A
Diode Forward Voltage	V _{SD}	V _{GS} =0V, I _S =-0.2A, T _J =25°C	---	---	-1	V

Notes:

1. Repetitive Rating: Pulsed width limited by maximum junction temperature.
2. The data tested by pulsed, pulse width ≤ 300μs, duty cycle ≤ 2%.
3. Essentially independent of operating temperature.
4. HTGB Reliability conditions follow up I_{GSS} spec.

N-Channel Typical Electrical and Thermal Characteristic Curves

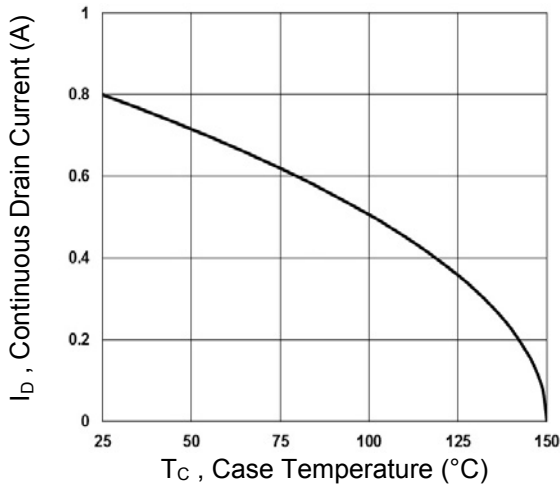

Fig.1 Continuous Drain Current vs. T_c

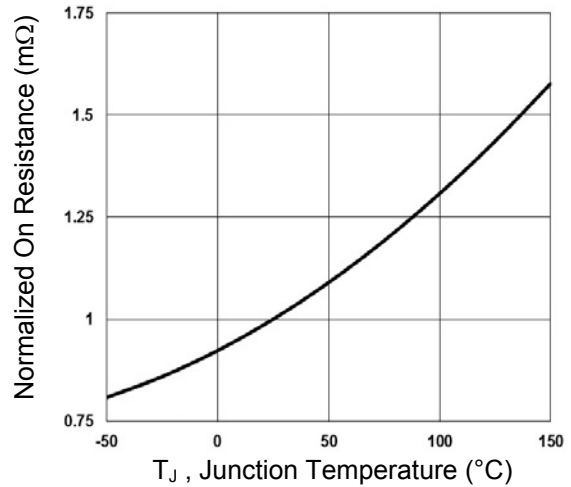

Fig.2 Normalized $R_{DS(ON)}$ vs. T_j

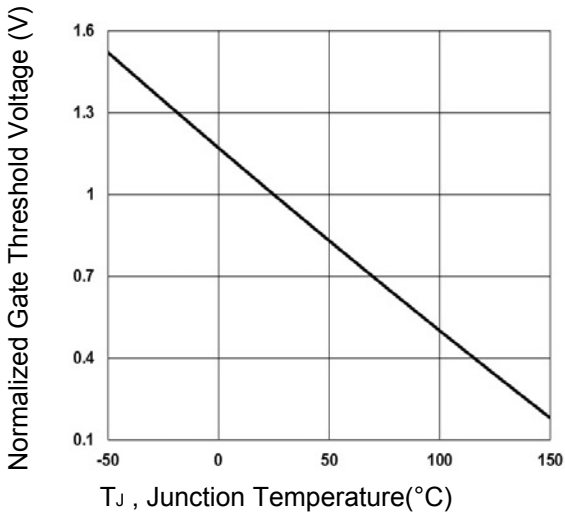

Fig.3 Normalized V_{th} vs T_j

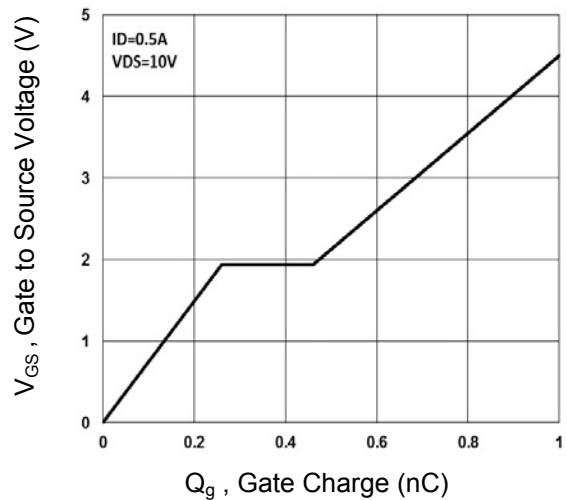

Fig.4 Gate Charge Waveform

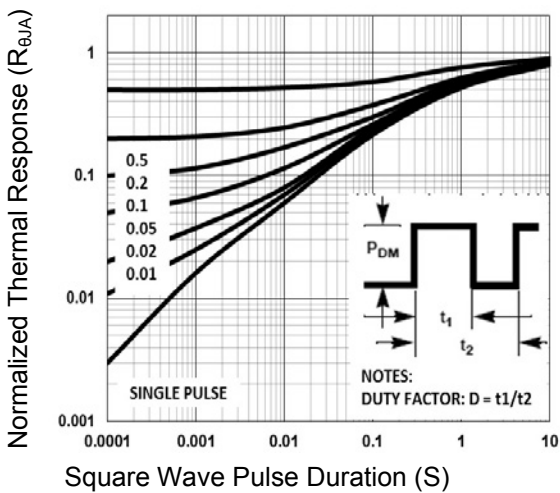

Fig.5 Normalized Transient Impedance

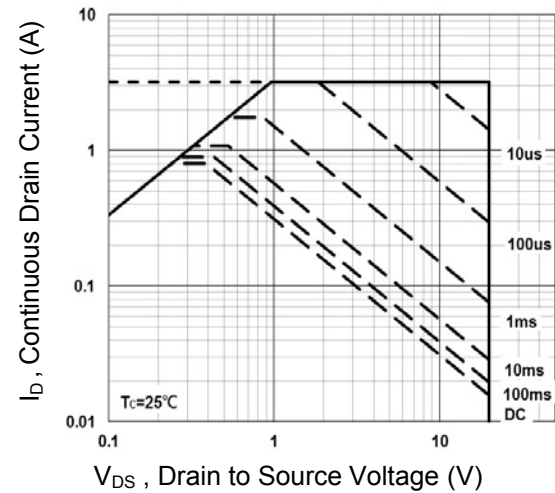

Fig.6 Maximum Safe Operation Area

P-Channel Typical Electrical and Thermal Characteristic Curves

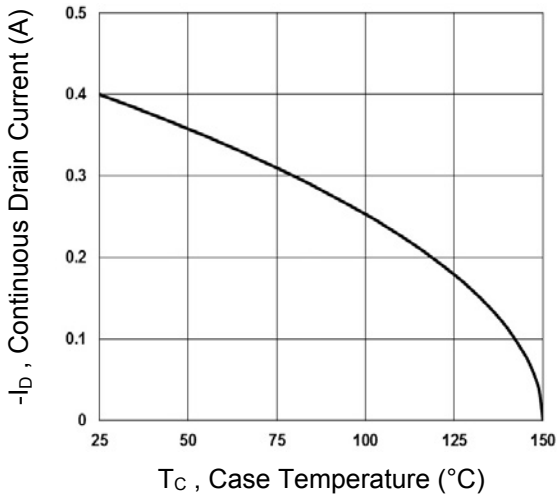

Fig.7 Continuous Drain Current vs. T_c

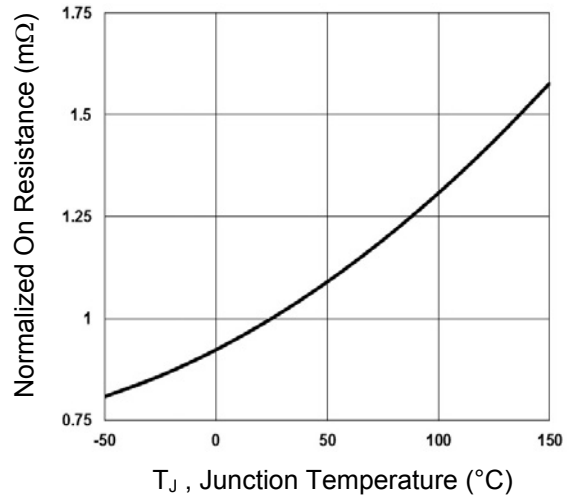

Fig.8 Normalized $R_{DS(ON)}$ vs. T_j

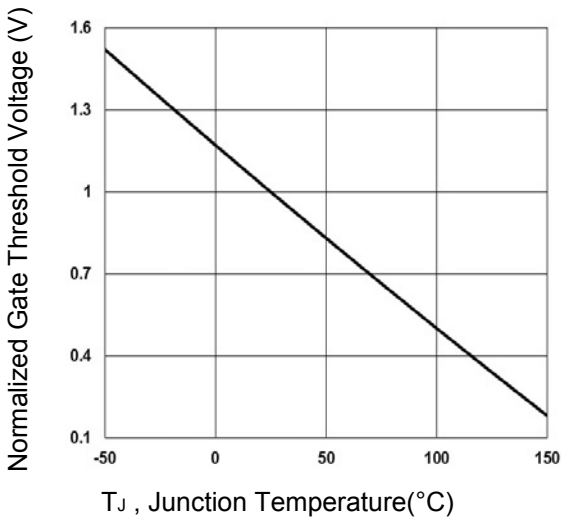

Fig.9 Normalized V_{th} vs T_j

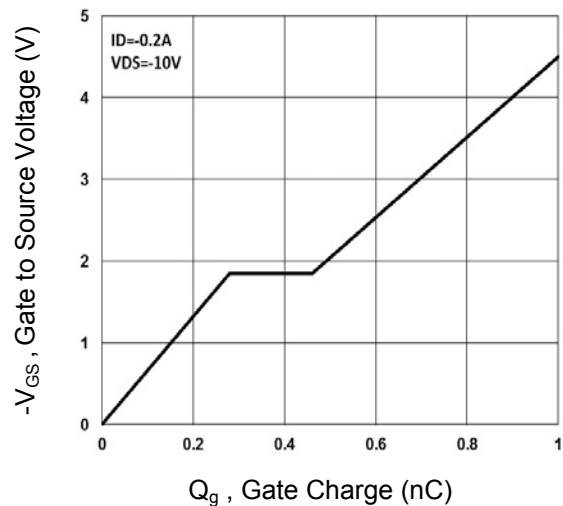

Fig.10 Gate Charge Waveform

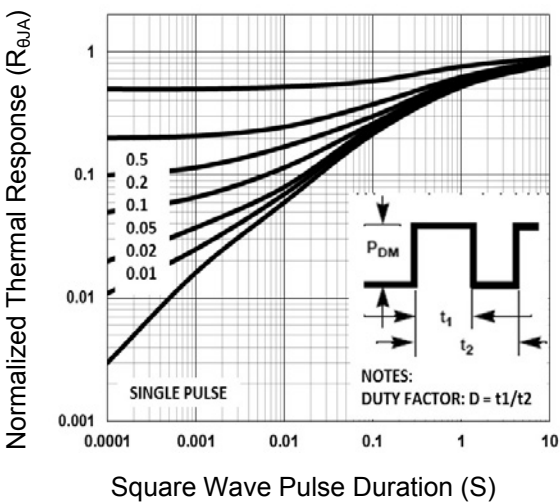

Fig.11 Normalized Transient Impedance

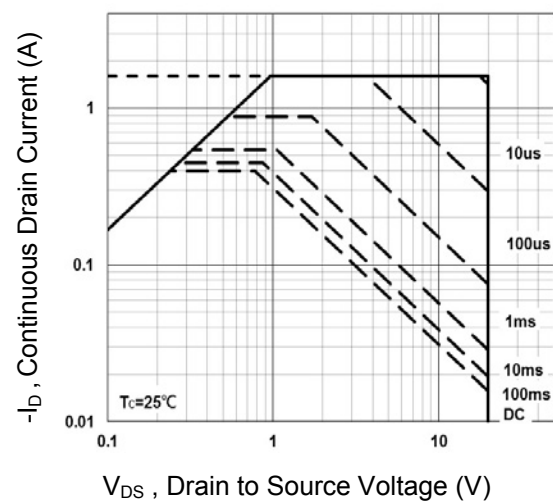
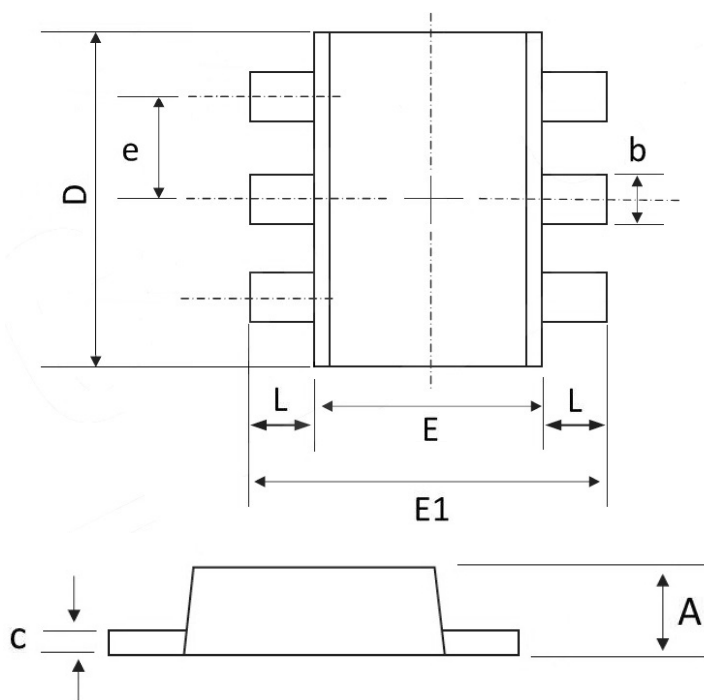

Fig.12 Maximum Safe Operation Area

Package Outline Dimensions

SOT-563



Symbol	Dimensions In Millimeters		Dimensions In Inches	
	MAX	MIN	MAX	MIN
A	0.600	0.500	0.024	0.020
b	0.300	0.150	0.012	0.006
c	0.180	0.100	0.007	0.004
D	1.700	1.500	0.067	0.059
E	1.250	1.100	0.049	0.043
E1	1.700	1.550	0.067	0.061
e	0.5BSC		0.02BSC	
L	0.300	0.100	0.012	0.004

Order Information

Device	Package	Marking	Carrier	Reel Quantity
SSF7120	SOT-563	DXY (X=Year, Y=Lot)	Tape & Reel	3,000pcs