

DATE	REV	ECN	APP'D. BY
09/18/18	A0	Released	DG

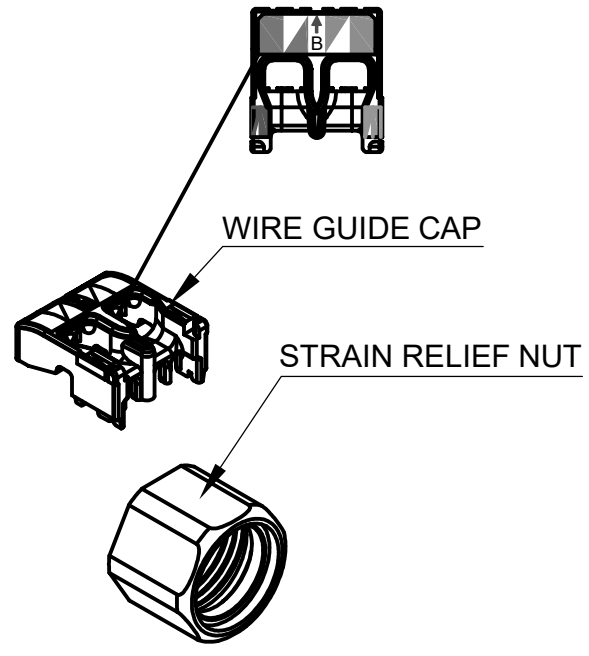
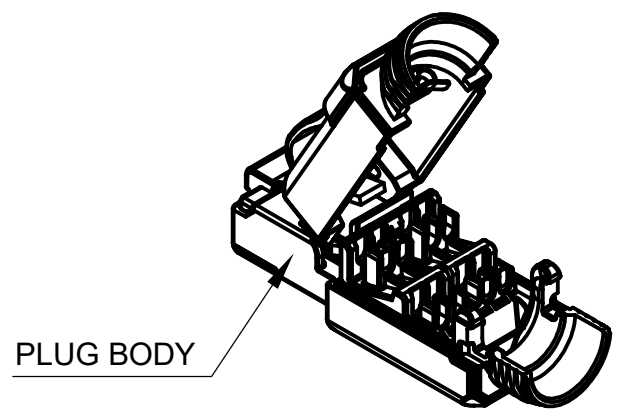
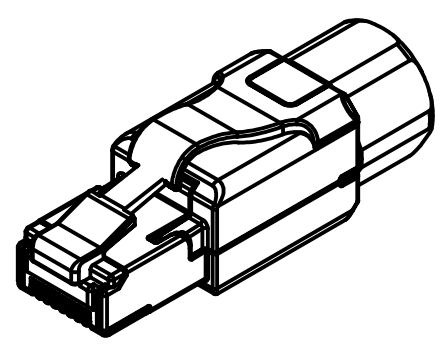

PLUG BODY

WIRE GUIDE CAP

STRAIN RELIEF NUT

**TRANSMISSION PERFORMANCE**  
 Meet all requirements specified in Patch Cord requirement of ANSI/TIA-568-C.2, Category 6A

**ELECTRICAL**  
 Electrical Insulation Resistance : 500MΩ min. @100V d.c  
 Dielectric Withstanding Voltage : 1000V D.C or A.C Peak,  
 Contact to Contact; 1500V D.C or A.C Peak,  
 Contact to Shield @ 60Hz for 1 Minute.

**MECHANICAL**  
 IDC Wire Gauge : 23 ~ 26 AWG

**PHYSICAL**  
 Housing : Zinc-alloy fully shielded  
 Contact pin : Phosphor Bronze Alloy Plated With 50 micro-inch of Gold  
 IDC : Phosphor Bronze Alloy With 100 micro-inch 100% Sn Alloy

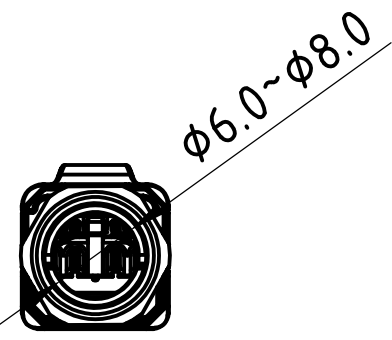
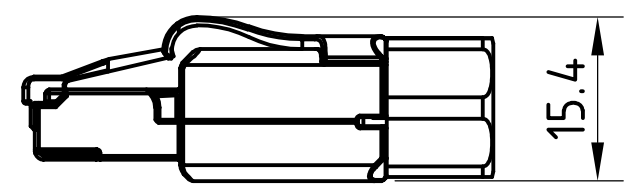
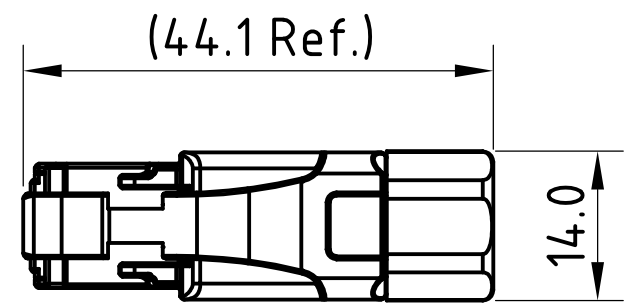

COMPONENTS		
ITEM	PART NAME	Q'TY
1	PLUG BODY	1
2	STRAIN RELIEF NUT	1
3	WIRE GUIDE CAP	1

SS-39300-002  
 PART NUMBER

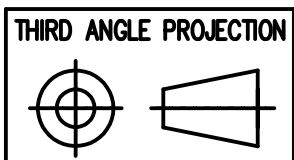
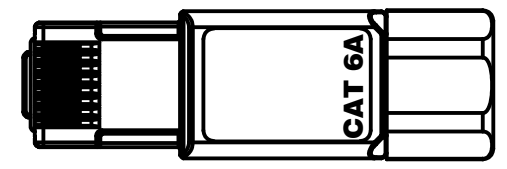
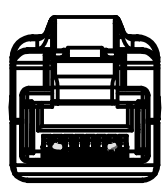

DO NOT SCALE DRAWING  
 DRAWING IS SUBJECT TO CHANGE WITHOUT NOTICE

DIMENSIONS: METRIC  
 UNLESS OTHERWISE SPECIFIED TOLERANCES ARE ±0.2  
 ANGLES ARE ± 1°

SHEET NO. 1 OF 1



11118 Susquehanna Trail South  
 Glen Rock, PA 17327-9199  
 (717) 235-7512  
<http://www.stewartconnector.com>

TITLE: CAT 6A FIELD TERMINATED PLUG

THIS DRAWING AND THE SUBJECT MATTER SHOWN THEREON ARE CONFIDENTIAL AND THE PROPRIETARY PROPERTY OF STEWART CONNECTOR AND SHALL NOT BE REPRODUCED, COPIED, OR USED IN ANY MANNER WITHOUT PRIOR WRITTEN CONSENT OF STEWART CONNECTOR. ONE OR MORE U.S. PATENTS MAY APPLY TO THIS PRODUCT. FOR DETAILS, PLEASE VISIT: [HTTP://BELFUSE.COM/STEWART/STEWART\\_PATENTS/](http://BELFUSE.COM/STEWART/STEWART_PATENTS/)

DRN BY: JM	DATE 09/13/18
APPD BY: DG	DATE 09/18/18
DWG NO. CT390202	REV. A0

