

Customer Information Sheet

DRAWING No.: M80-940XXXX SHEET 2 OF 2

IF IN DOUBT - ASK

©

NOT TO SCALE

THIRD ANGLE PROJECTION

ALL DIMENSIONS IN mm

ORDER CODE:
M80-940XXXX
 TOTAL No. OF CONTACTS
 06, 08, 10, 12, 14,
 20, 26, 34, 42, 50
 FINISH
 05 - GOLD CLIP, GOLD SHELL
 42 - GOLD CLIP, 100% TIN SHELL

SPECIFICATIONS:
 MATERIAL:
 CABLE HOOD = 30% GLASS-FILLED POLYAMIDE 46
 DATAMATE MOULDING = 30% GLASS-FILLED PPS,
 UL94V-0, BLACK
 CONTACT CLIP = BERYLLIUM COPPER
 CONTACT SHELL = BRASS
 JACKSCREW = STAINLESS STEEL
 CABLE HOOD FIXING SCREW = MILD STEEL
 FINISH:
 05 = 0.3µm GOLD CLIP, 0.25-0.3µm GOLD SHELL
 42 = 0.3µm GOLD CLIP, 3.5-5.0µm 100% TIN
 OVER NICKEL SHELL
 CABLE HOOD FIXING SCREW = CHEMI-BLACK
 ELECTRICAL:
 CURRENT RATING AT 25°C = 3.0A MAX
 CURRENT RATING AT 85°C = 2.2A MAX
 WORKING VOLTAGE = 800V AC/DC
 VOLTAGE PROOF = 1200V AC/DC
 CONTACT RESISTANCE = 25mΩ MAX
 INSULATION RESISTANCE = 100MΩ MIN
 MECHANICAL:
 DURABILITY = 500 OPERATIONS
 ENVIRONMENTAL:
 TEMPERATURE RANGE = -55°C TO +125°C
 PACKING:
 BAG
 FOR COMPLETE SPECIFICATION, SEE COMPONENT
 SPECIFICATION C005XX (LATEST ISSUE)

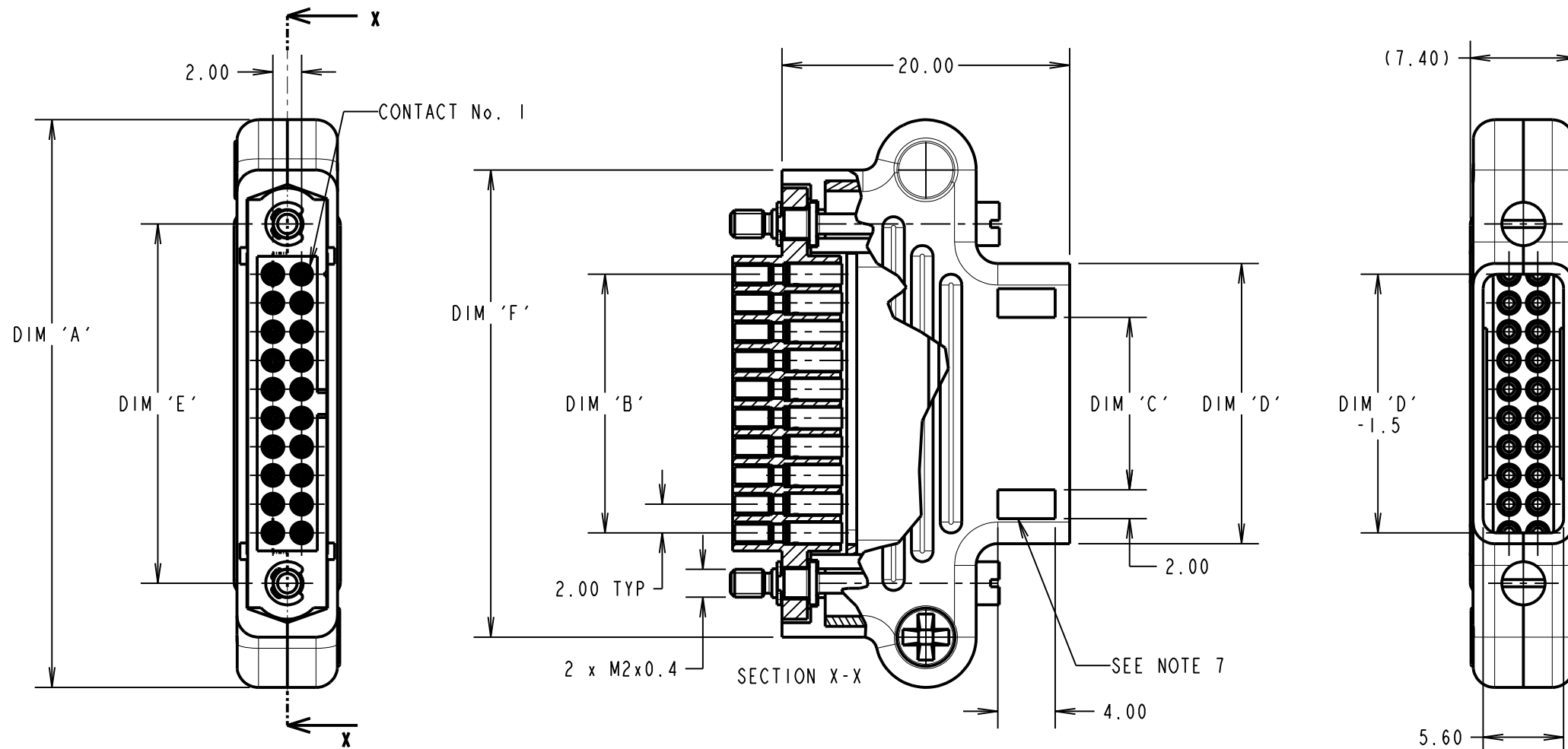

- NOTES:
- CONNECTORS ARE SUPPLIED WITH CONTACTS, CABLE HOOD SET, AND CABLE HOOD FIXING SCREWS LOOSE.
 - FOR EXTRA CONTACTS, USE PART NUMBER M80-01300XX (XX = 05 FOR GOLD FINISH, 01 FOR TIN FINISH).
 - RECOMMENDED WIRE TYPE = BS 3G 210 TYPE A, PTFE INSULATED 24-28 AWG. MAX INSULATION DIAMETER = Ø1.10mm, STRIP WIRE BY 2.00mm.
 - RECOMMENDED HAND CRIMP TOOL = M22520/2-01 WITH POSITIONER T5747. SEE TOOLING INSTRUCTION SHEET IS-01 FOR COMPLETE CRIMPING INSTRUCTIONS.
 - CONTACT INSERTION AND EXTRACTION TOOL = Z80-280. REFER TO INSTRUCTION SHEET IS-25 FOR ASSEMBLY INSTRUCTIONS.
 - NO CABLE TIE SLOTS ON M80-94006XX AND M80-94008XX.

PART NUMBER	No. OF CONTACTS	PART DIMENSIONS					
		DIM 'A'	DIM 'B'	DIM 'C'	DIM 'D'	DIM 'E'	DIM 'F'
M80-94006XX	6	25.50	4.00	N/A	5.50	11.00	18.50
M80-94008XX	8	27.50	6.00	N/A	7.50	13.00	20.50
M80-94010XX	10	29.50	8.00	2.00	9.50	15.00	22.50
M80-94012XX	12	31.50	10.00	4.00	11.50	17.00	24.50
M80-94014XX	14	33.50	12.00	6.00	13.50	19.00	26.50
M80-94020XX	20	39.50	18.00	12.00	19.50	25.00	32.50
M80-94026XX	26	45.50	24.00	18.00	22.50	31.00	38.50
M80-94034XX	34	53.50	32.00	26.00	33.50	39.00	46.50
M80-94042XX	42	61.50	40.00	34.00	41.50	47.00	54.50
M80-94050XX	50	69.50	48.00	42.00	49.50	55.00	62.50

FM	7	26.03.18	20940
NAME	ISS.	DATE	C/NOTE
APPROVED: F. MCGOWAN			
CHECKED: S. BENNETT			
DRAWN: N. CODLING			
CUSTOMER REF.:			
ASSEMBLY DRG:			

HARWIN

www.harwin.com
 technical@harwin.com

THIS DRAWING AND ANY INFORMATION OR DESCRIPTIVE MATTER SET OUT HEREON ARE CONFIDENTIAL AND COPYRIGHT PROPERTY OF THE HARWIN GROUP AND MUST NOT BE DISCLOSED, LOANED, COPIED OR USED FOR MANUFACTURING, TENDERING OR FOR ANY OTHER PURPOSE WITHOUT THEIR WRITTEN PERMISSION.

TOLERANCES
 X. = ±1mm
 X.X = ±0.50mm
 X.XX = ±0.10mm
 X.XXX = ±0.01mm
 ANGLES = ±5°
 UNLESS STATED

MATERIAL:
 SEE ABOVE
 FINISH: SEE ABOVE
 S/AREA: mm²

TITLE: JACKSCREW DATAMATE DIL CRIMP (SMALL BORE) FEMALE ASSY WITH CABLE HOOD KIT

DRAWING NUMBER: **M80-940XXXX** SHT 2 OF 2