

Product Document



**high
performance
needs great
design.**

Coverpage: AS73211-AB5 Datasheet

Please be patient while we transfer this adapted former MAZeT document to the latest ams design.

DATASHEET

AS73211-AB5

JENCOLOR® - Sensor Board with I²C-Interface

Order No.: 220810002

Status: preliminary

INTRODUCTION

This document describes the hardware of the AS73211-AB5 designed by ams Sensors Germany. The OEM sensor solution is a small PCB for general color measurement and control applications, with a high bandwidth for light energy and optimized for handheld applications. The board is suitable for benchmarks, feasibilities or as OEM solutions for tests.

The sensor board includes the True Color sensor AS73211 with I²C interface [1], which filters are based on the international CIE 1931 standard. The sensor also includes an analog-to-digital converter which realizes a current-to-capacity digitizing within a high dynamic range and 20 Bit ADC solution. Further components on board are an EEPROM, power regulator and a standard I²C-interface. I²C is used for external communication, configuration of the sensor, readout of the sensor data as well as reading and writing of the memory. Figure 1 shows the block diagram.

At the I²C Bus is also still the EEPROM connected. The bus is directly accessible via a connector. The power supply of the module is also carried out via this connector. A linear regulator generates the system voltage and supplies via filter the analog and digital circuit of the sensor.

Figure 1: Block diagram AS73211-AB5

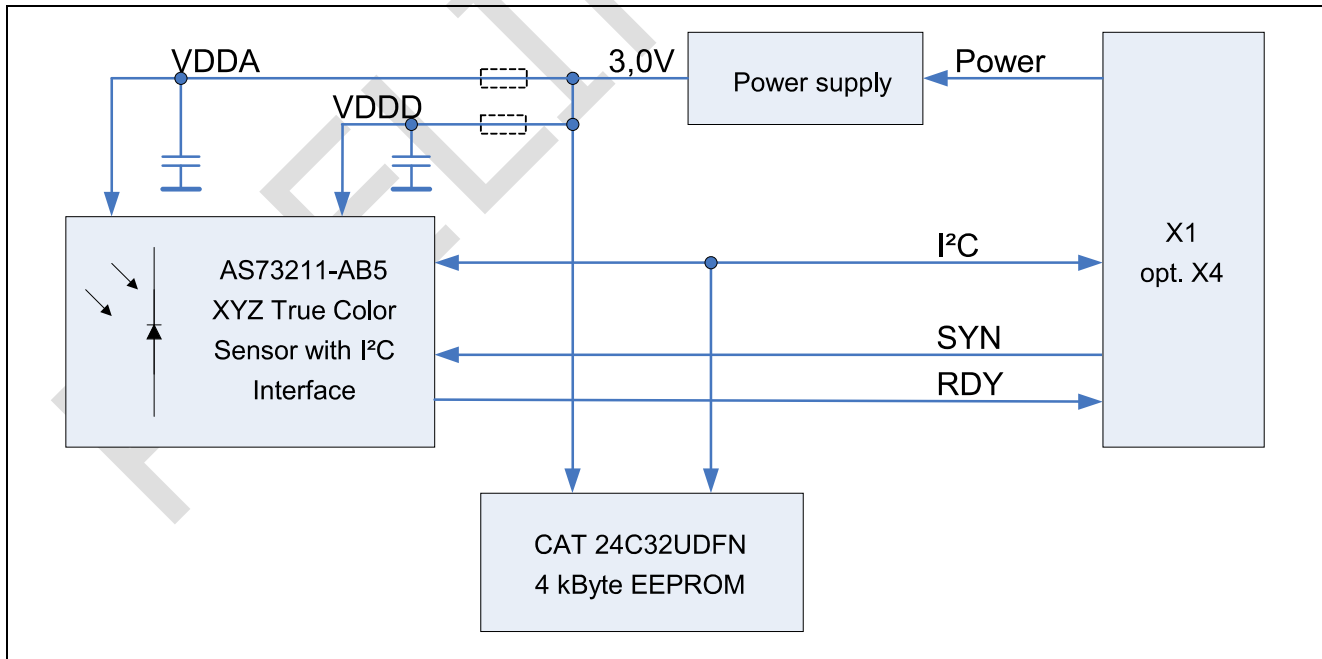

INTRODUCTION 1

1 OVERVIEW 3

2 HARDWARE 4

 2.1 True Color Sensor Function On Chip 5

 2.2 Current-to-Digital-Converter 6

 2.3 EEPROM..... 7

 2.4 Power Supply 7

 2.5 Hardware Interface and Test Points 7

3 OPTICAL INTERFACES OF AS73211-AB5 9

4 MAXIMUM CONDITIONS 10

5 APPLICATION NOTES 10

 5.1 Application-Specific System Configuration 10

 5.2 Calibration 10

 5.3 Calibration of Emitting Measuring Objects 10

 5.4 Active Feedback Light Color Control (Color Regulation) 12

6 NOTES 13

7 REFERENCE DOCUMENTS..... 13

ORDERING INFORMATION 14

LEGAL NOTES AND WARNINGS 15

PRELIMINARY

1 OVERVIEW

In the following the main components for AS73211-AB5 are described.

Table 1: Overview of the essential components and parameters

AS73211-AB5	
Color sensor	True Color XYZ sensor detection comparatively as CIE1931 / DIN5033 for sensitivity and gain, see [1]
Temperature sensor	On ASIC - AS73211, see [1]
EEPROM	4kByte, addressable via I2C
Electronic interface	Fitted Standard I ² C 400kHz – for communication
Optical interface	Plastics aperture (to click on board) to realize angle of incidence

Figure 2: PCB overview (Front and rear panel)

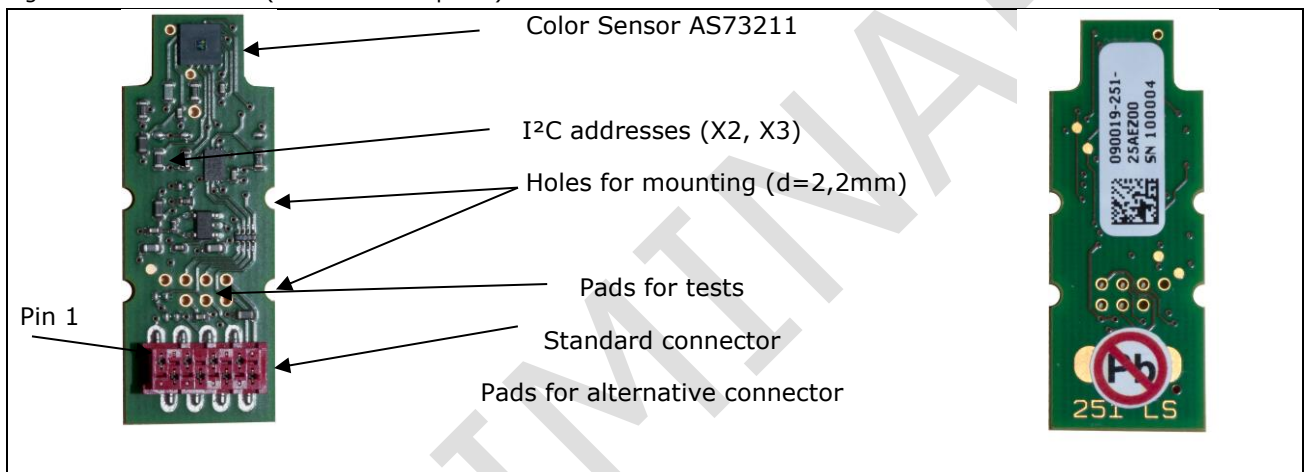
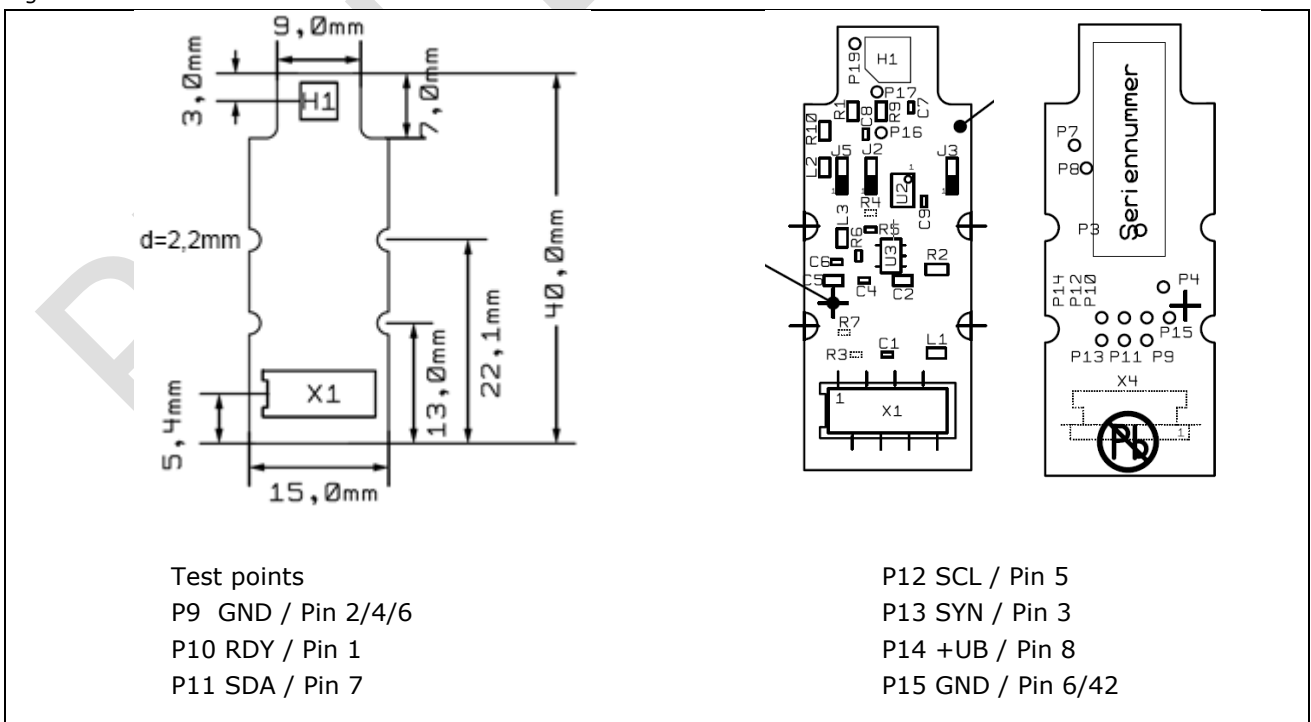

Figure 3: PCB dimensions



2 HARDWARE

Figure 4 shows the schematic and pinning of the connectors and test points. Please compare the terminology within the Figure 2, Figure 3 and chapter 2.5

Figure 4: Schematic of reference design

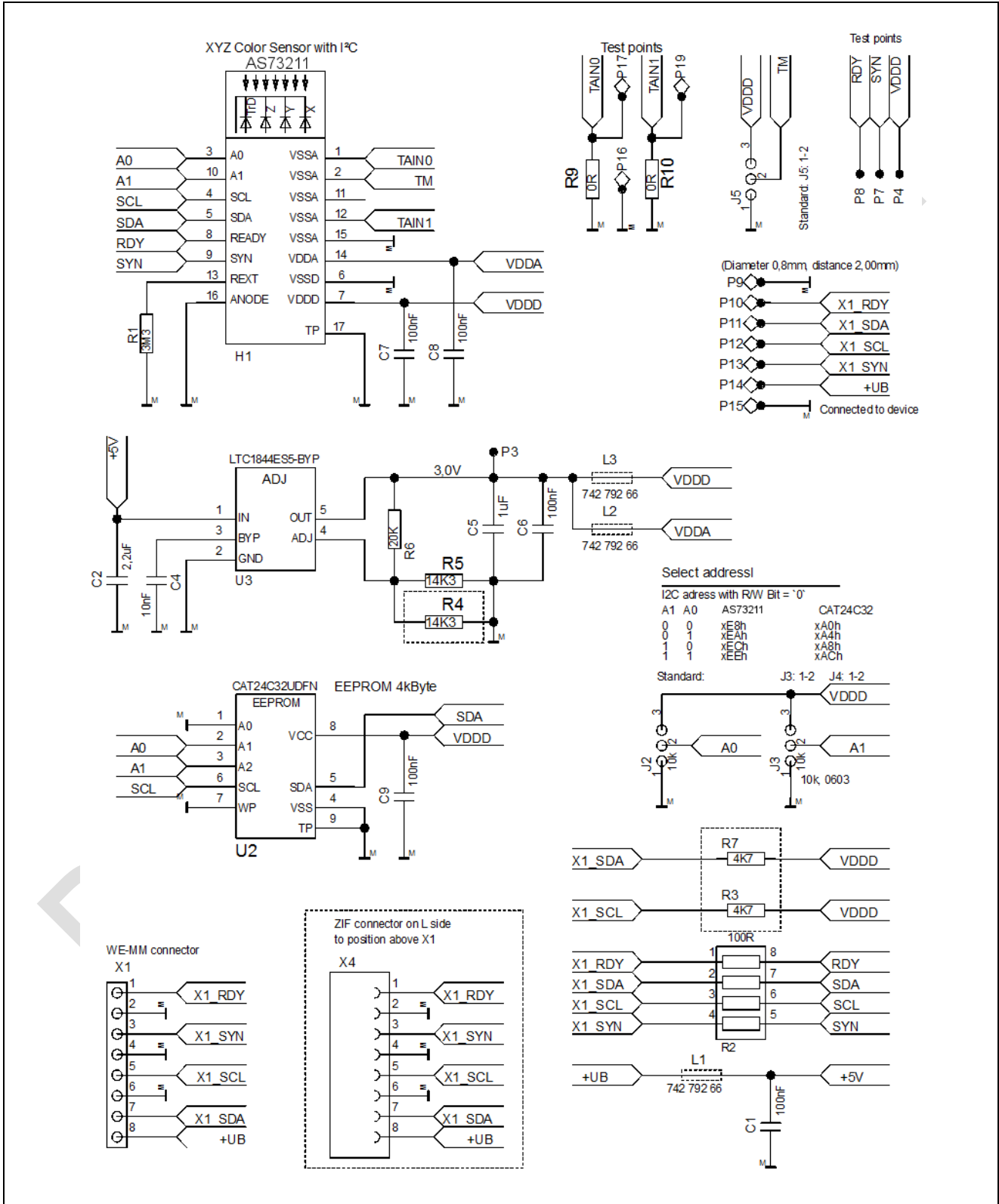

The following chapters describe the typical main components of the AS73211-AB5. Please note, on board are some special schematics to optimize the sensor functions (TrD¹) or to stabilize power supply and (filter chokes and capacitors) other preconditions. For that you will find more details in [1] and [2]. Please check these schematics for your needs or ask our sales team.

2.1 True Color Sensor Function On Chip

One of the central components of AS73211-AB5 is the True Color JENCOLOR[®] sensor technology. These are photodiodes with XYZ (comparatively as CIE1931) coated interference filters. The diodes are aligned as square segments and located in center of the sensor element [see 1 – package].

Figure 5: True color sensor AS73211 from JENCOLOR[®]



Each of the photodiodes on chip is sensitized with like XYZ True Color (preferably for the color standard² CIE 1931 - Commission Internationale de l'Eclairage or International Commission on Illumination) dielectric spectral filters shown in Figure 6.

Figure 6: Typical (relative) sensitivity (XYZ) of the color sensor (AS73210) scanned by width broadband light and limited angle of incidence (<math><10^\circ</math>)

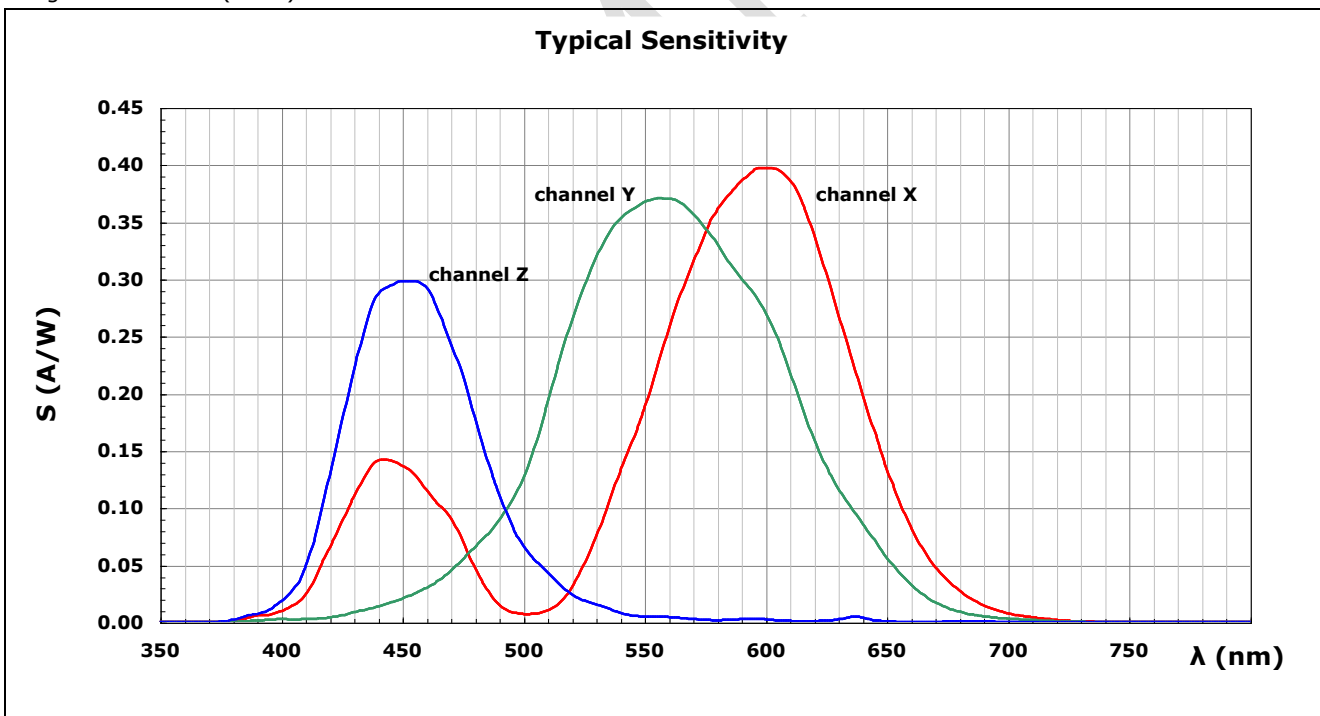

The used JENCOLOR[®] interference filter technology guarantees high transmission in the band pass range, a very low rest transmission, resistant to aging effects and long-term stable against mechanical and temperature influences during processes.

¹ TrD is an added-isolation diode to split up the potential of the 3 functional pin diodes XYZ.

² For more details see http://en.wikipedia.org/wiki/CIE_1931_color_space

2.2 Current-to-Digital-Converter

The AS73211 includes a low power, low noise current-to-capacity-to digital converter. Three of these channels convert the light signals of photodiodes to a digital result and realize a continuous or triggered measurement. The irradiance responsivity can be set in a range of 12 steps by a factor of 2 for each step. The conversion time is internally controlled over a wide range of 15 steps by a factor of 2 for each step. Optional the conversion time can be externally controlled via input pin SYN to adapt the measurement to the given environment and time base. These features allow the sensor to be perfectly utilized for applications of color measurements in a huge range of input light intensity.

With its irradiance responsivity factor and conversion time the AS73211-AB5 supports a dynamic range of 1-to-250,000,000 and achieves an accuracy of up to 16 bit (internal 20 bit) signal resolution with an irradiance responsivity per count down to 0.0005 $\mu\text{W}/\text{cm}^2$.

Based on the AS73211 the sensor board solution also includes an inherent ripple rejection of the 50 Hz/60 Hz external disturbances. It is especially designed to ensure high accuracy at high sensitivity offering high robustness. Automatic Power Down (sleep function) between subsequent measurements offers operation with very low current consumption. Further, it offers a wide range of irradiance responsivity (0.034 counts/ $(\mu\text{W}/\text{cm}^2)$ to 2.1e6 counts/ $(\mu\text{W}/\text{cm}^2)$), conversion times (125 μs to 16.384 s) and synchronized mode and other control modes adjustable by user programming. The conversion data can be accessed via 16 bit/400 kHz fast mode I²C interface with programmable slave addresses. The measurement of the actual conversion time for an external triggered measurement can be performed.

The supported operating modes of the AS73211 are:

- CMD Mode – single measurement and conversion (controlled via I²C interface),
- CONT Mode – continuous measurement and conversion (periodically recurring measuring cycles) start and stop controlled via I²C interface,
- SYN[x] modes - synchronized measurement and conversion:
 - [SYNS Mode] synchronization of start via control signal at pin SYN,
 - [SYND Mode] synchronization of start and stop of measuring cycles via control signal at pin SYN.

Figure 7: Block diagram AS73211

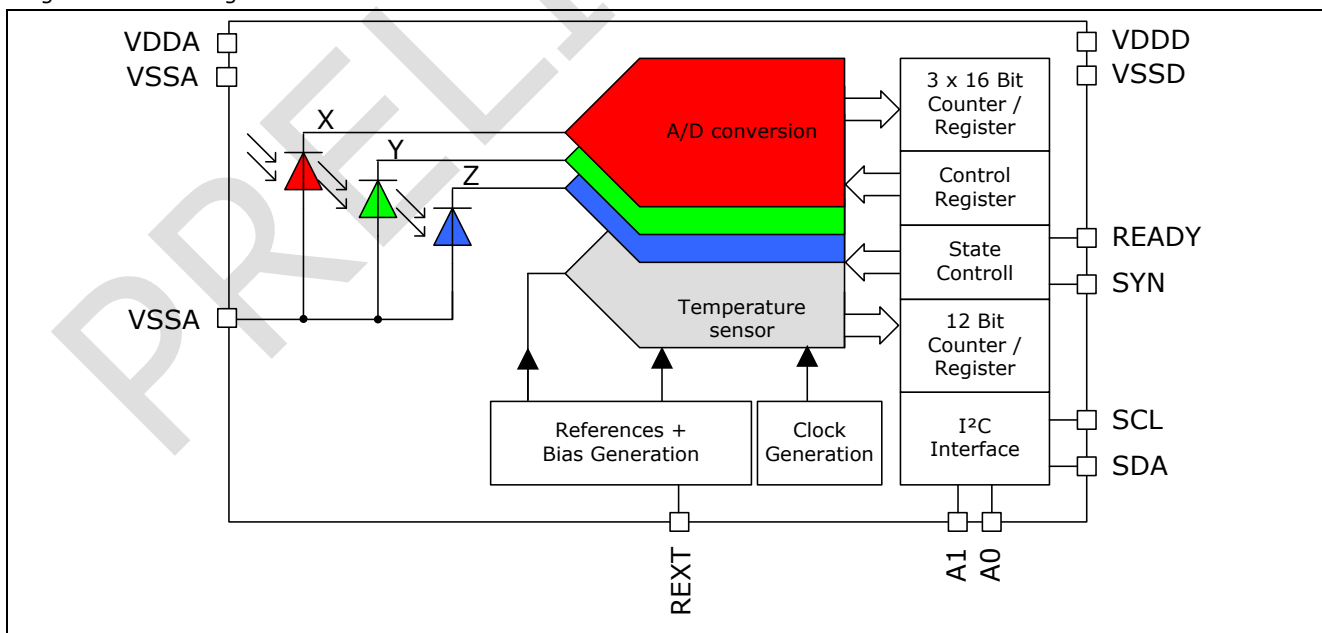

The settings of the irradiance responsivity and conversion time are not affected by the measurement modes but affects the sensitivity, numbers of digits, ratio between noise and signals and last not least the accuracy of the sensor system. For more details to optimize sensitivity and accuracy and/or to behind saturation see [1] and [3].

The digital values and results of the ADC are stored in an I²C Interface. With an internal temperature sensor, the sensor temperature can be measured and read also via I²C. Following table shows the sequence of sensor results.

Table 2: Sequence of ADC results via I²C

ADC	DESCRIPTION
ADC0	Digits of X - filter
ADC1	Digits of Y - filter
ADC2	Digits of Z - filter
ADC3	Digits of temperature sensor



Note: For further details on the ASIC, modes of operation, the registers and the protocol for programming, the data and the I²C interface which is also valid for the AS73211-AB5 sensor board solution please refer to the data sheet of the True Color sensor AS73211 [1].

2.3 EEPROM

An EEPROM (type AT24C32UDFN; 4kByte) is integrated for calibration purposes and to save the sensor-typical parameters. The communication to the EEPROM is via I²C (see [2]).

2.4 Power Supply

The sensor board is supplied with voltage via the standard connector. A series regulator on board (type LTC1844ES5-BYP, see [4]) provides the internal operating voltage of 3.0V. It is able to move in the range between 3.3V -5% up to 5 V +10%. The analog and digital components are supplied via filter.

2.5 Hardware Interface and Test Points

The connector X1 is used for external power supply and communication. Examples of an adequate connector are 6903 6728 08 67 from Würth Elektronik. The counter part is 6901 5700 08 72 from Würth Eletronik. A flat cable with grid dimensions of 1.27 mm is used a interconnector. The maximum length is 0.5m.

As a contacting option X2 use a ZIF connector with 0,5mm pitch (e.g. FH12-8S-05.SH from Würth Elektronik) at the end of the backside. A further possibility for connecting is the use of the contact pads P9 to P14 (related test points).

Table 3: PIN assignment X1 and X2 and test points

PIN	LABEL	TYPE	FUNCTION	RELATED TEST POINT
1	RDY	out	ready signal AS89010	P10
2	GND		ground	P9
3	SYN	in	trigger AS89010	P13
4	GND		ground	P9
5	SCL	in	I ² C, serial clock input	P12
6	GND		ground	P9
7	SDA	in/out	I ² C, serial Data	P11
8	VDD		supply voltage	P14

The amplification circuitry and memory consist of a joint I²C interface. The data structure is shown in [1].

The soldering bridges J1 and J2 allow individual addressing, which offer the possibility to have a parallel connection of up to four AS73211-AB5 (based on the EEPROM AT30TSE754).

Table 4: Addressing via Solder Bridge

AS73211-AB5 Board	Jumper J3 (A1)	Address A1	Jumper J2 (A0)	Address A0	I ² C-Address AS73211	I ² C-Address EEPROM	I ² C-Address Temperature sensor
1 (default)	1-2	0	1-2	0	xE8h	xA0h	X90h
2	1-2	0	2-3	1	xEAh	xA4h	X94h
3	2-3	1	1-2	0	xECh	xA8h	X98h
4	2-3	1	2-3	1	xEeh	xACh	X9Ch

3 OPTICAL INTERFACES OF AS73211-AB5

The spectral filters of ams Sensors Germany's color sensors are specialized for applications with a broadband source of lighting >10 nm. Please ask our sales team before you use our sensor in combination with narrowband luminous sources.

Based on the packaging, the sensor IC has an aperture angle (beam width) of nearly 90°.

Attention: By nature of physics, interference filters work depending on the angle of incidence. So a diverted light beam with altered vertical angle up to 10° will not cause any filter shifts. Make sure that the angle of incidence to the sensor device is less than 10° by using lenses, optical holes or casings. For initial operation tests ams Sensors Germany offers an aperture cover plate. This simple construction can be attached onto the sensor board.

The section around the color sensor AS73210 is 9 mm wide and was specially designed to fit the mentioned "Optical cover" (see Figure 8).

Figure 8: Add-on component "Optical cover Article E082Z000847³" to limit angle of aperture

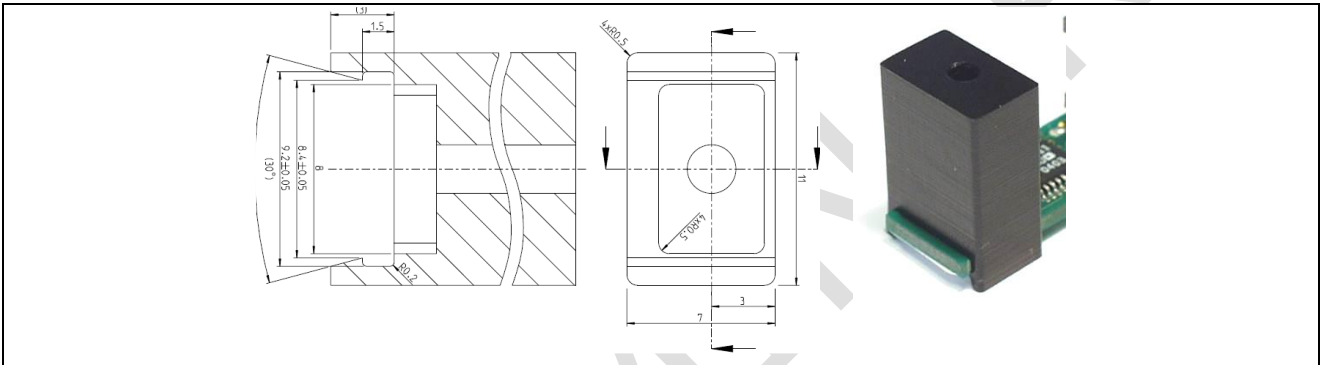

This optional optical cover on the circuit board can be used to limit the angle of aperture / incidence (max. $\pm 10^\circ$ of vertical beam). A special contact surface is used to connect the optical cover to the circuit board, therefore a 2 mm spacing area around the connector and sensor exists. Additionally, two notches are included for equipping a casing.

Another delivery form of the AS73211-AB5 inserts an alternative optical interface like described here. Figure 9 shows the mechanical package of the Development Kit MTCS-INBT-AB5 [6] which includes an alternative optical interface as well as ESD protected casing.

Figure 9: Mechanical package of DK AS73211-AB5

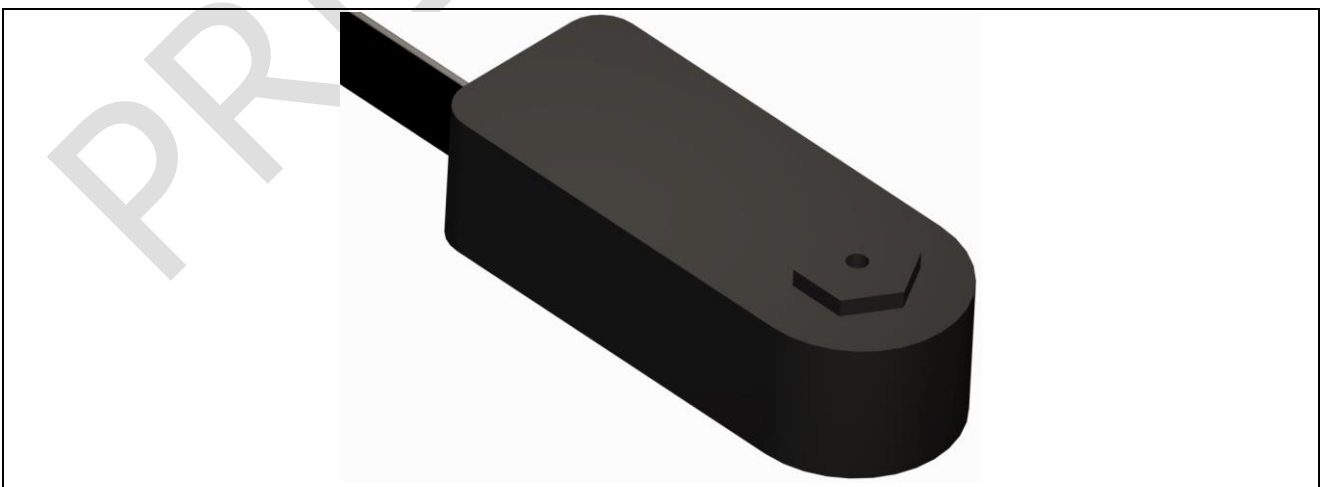

³ Use this article number to order it via email to sales-europe@ams.com

4 MAXIMUM CONDITIONS

Table 5: Maximum conditions

FEATURE	COMMENT	UNIT	VALUE	
			MIN	MAX
TS	Storage temperature	°C	-25	+100
TB (functional)	Operating Temperature	°C	-25	+100
Power Supply		V	3.3 V -5%	5 V +10%

5 APPLICATION NOTES

5.1 Application-Specific System Configuration

It is advisable to administrate as much light as possible onto the sensor in order to keep the amplification low and therefore improve the signal-noise ratio⁴.

For slow and highly precise measurements using an integrating (INT) board the time basis selected should be as high as possible. In addition, the integration time can be extended by increasing the acquisition counter. When measuring pulsed objects (for example PWM light sources), the integration time must be a multiple of the pulse frequency. Without an EMC casing, the integration time should also be a multiple of the line frequency of 50 Hz in order to avoid overlapping frequency fluctuations (beat effects). The spectral filters of our color sensors are specialized for applications with a broadband source of lighting >20 nm.

Please ask our sales team before you use our sensor in combination with narrowband luminous sources.

As a first system test we suggest to use our source development kit DK AS73211-AB5. This kit includes the AS73211-AB5 OEM sensor board, fitted into a metallic case with optical interface, a standard I²C-USB converter and test software to control the converter and data logging. Please ask our sales team further information.

5.2 Calibration

The digitized sensor values must be converted into color coordinates or spectral data depending on the application. Various transformations and algorithms can be used for this purpose. The corresponding parameters are specifically adapted to the application by appropriate sensor calibrations and determined once for each sensor. The basis is formed by application target sets with known colorimetric or spectral data. There are many different known methods for calibration. These, the selected targets and their reference values decide about the accuracy of the sensor system in use. In the following and next chapters an example will be shown for calibration by using a [3x3] correction matrix by the method of linear progression.

For further enquiries please contact our sales partners or offices.

5.3 Calibration of Emitting Measuring Objects

A requirement for the measurement of emitting objects (self-luminous) is the calibration of the color sensor using a light source setting where the chromatic values are first determined by an appropriate spectrometer or by known XYZ values (based on CIE1931 standard). Use targets for calibration which represent the full gamut of the application. Please note, not more targets will increase the accuracy for the sensor system

⁴ Note, the accuracy is depend on the system conditions, calibration and interferences. Therefore in application specific systems the sensor system must be optimized to increase accuracy. E.g. IR lighting will reduce the signal noise ratio dramatically. An add-one IR blocking will correct that.

but linearity and optimized references are the guaranty for an optimal calibration which results the required True Color quality. Each application and calibration is based on a unique optimized calibration set exists from light source, target (number and specified colors), calibration method and requirements for accuracy. So we suggest to make simulations to find the optimized specification or contact the ams Sensors Germany team for support this process.

Examples for calibration method:

For determining the chromaticity coordinate, the differing maxima of the spectral sensitivity conditions of the Tri-stimulus value functions are adjusted, with simple scaling or matrixing, to the Tri-stimulus values. The calibration outlay employed is based on one which is accordant with technical feasibility in series manufacture as well as the required measurement and control accuracy.

With simple scaling, each XYZ(measured) channel has been multiplied by a predetermined simple correction factor K, so that the signal conditions correspond to the Tri-stimulus values XYZ(corrected) for a selected radiating function or combination Color / white point. This method is applicable when the temperature influences are disregarded and with constantly regulated brightness.

Formula 1: Scaling of sensor results

$$\begin{pmatrix} x_{COR} \\ y_{COR} \\ z_{COR} \end{pmatrix} = \begin{pmatrix} x_K \\ y_K \\ z_K \end{pmatrix} * \begin{pmatrix} x_{MEA} \\ y_{MEA} \\ z_{MEA} \end{pmatrix}$$

Another simple method (formal matrixing) without reference values and spectral correction for the sensor is to use a simple matrix [3:3] with diagonal "1". This calibration is not real and valid for measurements but represents only a direct transformation of the measured and not corrected sensor values in the color space. The results of this method meet not any absolute accuracies. The method recommended only for certain relative color measurements in the selected color spaces.

Formula 2: Formal matrixing of sensor results

$$\begin{pmatrix} x_{COR} \\ y_{COR} \\ z_{COR} \end{pmatrix} = \begin{pmatrix} 1 & 0 & 0 \\ 0 & 1 & 0 \\ 0 & 0 & 1 \end{pmatrix} * \begin{pmatrix} x_{MEA} \\ y_{MEA} \\ z_{MEA} \end{pmatrix}$$

An advanced method, which is also used in the majority of applications, is the use of a transformation matrix (Formula 2 for linear transfer of the sensor data into XYZ Tri-stimulus values. Unlike with scaling, matrixing also changes the brightness linearly.

Formula 3: Matrixing of sensor results

$$\begin{pmatrix} x_{COR} \\ y_{COR} \\ z_{COR} \end{pmatrix} = \begin{pmatrix} x_{K11} & x_{K12} & x_{K13} \\ y_{K21} & y_{K22} & y_{K23} \\ z_{K31} & z_{K32} & z_{K33} \end{pmatrix} * \begin{pmatrix} x_{MEA} \\ y_{MEA} \\ z_{MEA} \end{pmatrix}$$

It is relatively simple to determine a correction matrix for LED sources and to convert it into series production. This causes the adjustment of at least three (n) full or combination Colors, which are independent from each other, with known Tri-stimulus values XYZ. The n calibrated Colors are successively adjusted to the source. This occurs at the same time as the Tri-stimulus values, with a pre-calibrated three-range sensors, are measured and the RGB sensor data is recorded. Consequently, the measurement data constitutes a required matrix XYZ and the sensor data constitutes an actual matrix RGB, each with three rows and n columns. The calculation for the coefficient matrix is shown in the following formula.

Formula 4: Calculation of coefficient matrix

$$Matrix = \begin{pmatrix} x_{K11} & x_{K12} & x_{K13} \\ y_{K21} & y_{K22} & y_{K23} \\ z_{K31} & z_{K32} & z_{K33} \end{pmatrix} * = (XYZ * XYZ_{MEA}^T) * (XYZ * XYZ_{MEA}^T)^{-1}$$

With this coefficient matrix, all the following sensor data's (XYZ_{MEA}) are transferred linearly in accordance with Formula 3 into standard Tri-stimulus values XYZ and provides the basis for conversion into any Color standards. For more details see [5] or contact ams Sensors Germany team.

5.4 Active Feedback Light Color Control (Color Regulation)

Color measurement tasks can be fulfilled using a variety of technologies. Three-range RGB color sensors are compact and optimized for rapid color detection. Using RGB filters, these are only suitable for color detection, e.g. measurement of relative color difference.

True Color sensors by JENCOLOR® with XYZ filter have a filter characteristic that makes them suitable for absolute color measurement. With these sensors it is possible to control the colored light of any number of RGB LEDs with a precision not available using RGB filters. This is made possible by the standard spectral value function of the sensor, which replicates the color vision of the human eye.

The result is a system for capturing the LED light that emulates the color perception of human eyes. Therefore it is possible to control the color of the light to a precision level that any color changes are beyond recognition, therefore invisible to the human eye.

At the same time, the sensor remains solid in its constancy, since it is not disposed to any aging effects or influenced by temperature in respect of the measured color point. It is therefore suitable for use wherever the precision and stability of the colored light are essential - such as in feedback solutions for general lighting solutions, the calibration of the cabin lights of aircrafts, for the background lighting of LCD displays, or as color management system in digital cameras.

True Color sensors allow a generation of natural light sources bases on multi-LEDs and other mixed light sources. This, for example, may be necessary where ambient light is measured and the missing spectral components are then added to produce the required light setting.

Figure 10: Design of a feedback control loop using XYZ sensors

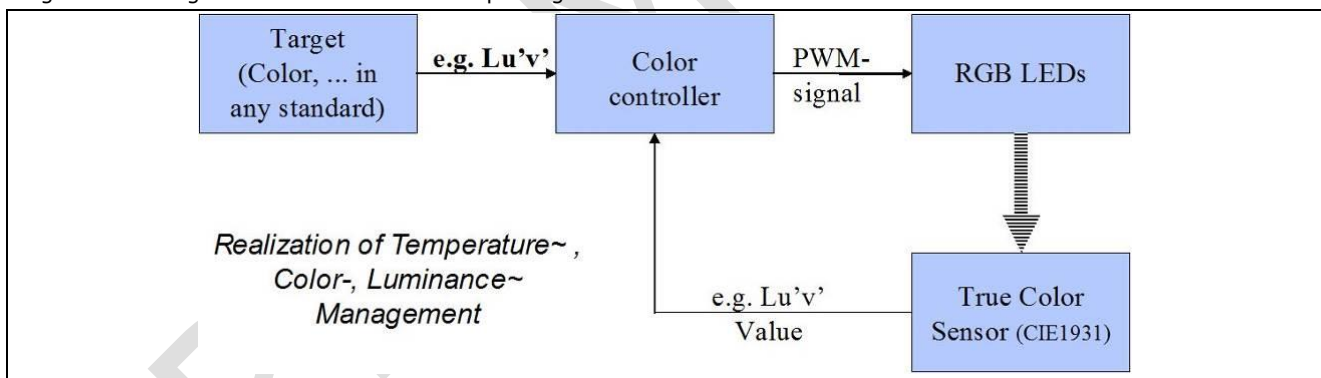

6 NOTES

It is essential to keep the sensor surface clean. Dust or scratches will adversely affect the sensor parameters. Sensors should be handled with care, like all optical devices. It is important to perform normal ESD handling and precautions for ESD sensitive devices.

7 REFERENCE DOCUMENTS

- [1] AS73211, datasheet, ams Sensors Germany
- [2] "EEPROM CAT24C32-D Rev.14, datasheet, ON Semiconductor"
- [3] AS89010, application note, ams Sensors Germany
- [4] "LTC1844, Rev. A", datasheet, Linear Technologies
- [5] "20160118 MTCS from adc to calibration and adjustment.*", application note, ams Sensors Germany
- [6] AS73211-AB5 SET DK, datasheet, ams Sensors Germany

PRELIMINARY

ORDERING INFORMATION

NAME	STATUS	ARTICLE
AS73211-AB5	Series	220810002

PRELIMINARY

For more information please contact:

ams Sensors Germany GmbH:

Göschwitzer Straße 32
07745 JENA | GERMANY
Phone: +49 3641 2809-0
Fax: +49 3641 2809-12
sales-europe@ams.com
www.ams.com

LEGAL NOTES AND WARNINGS



Failure to comply with these instructions could result in death or serious injury.

Misuse of documentation – The information contained in this document is the property of ams Sensors Germany. Photocopying or otherwise reproducing any part of the catalog, whether electronically or mechanically is prohibited, except where the express permission of ams Sensors Germany GmbH has been obtained. In general, all company and brand names, as well as the names of individual products, are protected by brand, patent or product law.

State of document - The information provided in this document is for reference only. Do not use this document as product installation guide since products can be under development to improve performance or any other purpose. Before you start any development or place an order please contact your supplier or ams Sensors Germany for the latest version of this document. ams Sensors Germany explicitly reserves the right to make technical changes to information described in the document.

Information and Disclaimer – The information provided in this document is based on the knowledge of the ams Sensors Germany GmbH as of the date of publication. The ams Sensors Germany GmbH cannot give warranty regarding the accuracy of information provided by third parties. ams Sensors Germany may not have conducted testing or chemical analysis on all incoming material or chemicals. ams Sensors Germany GmbH performs and continues to perform reasonable measures to provide the most accurate data at the given time. Additional efforts to integrate information provided by third parties are performed and continue to be performed. Certain supplier information may be proprietary or limited and not available at release.



Personal Injury: All products are conform to the specifications in accordance with the terms and conditions of ams Sensors Germanys standard warranty. Production processing does not necessarily include testing of all parameters.



RoHS Directive 2011/65/EU /REACH INFORMATION - RoHS compliance and PB free: The products of ams Sensors Germany fully comply with the current RoHS-directives. Our semiconductor products do not contain any of the six substance chemical categories, for example including the restriction on lead usage (lead weight may not exceed 0.1% in homogeneous materials). RoHS compliant products are suitable for the usage in lead-free specified processes, when designed to be soldered at high temperatures.

REACH information: ams Sensors Germany products do not contain any of the latest REACH Substances of Very High Concern (SVHC) regarding the Europe Union (EU) Regulation 1907/2006. The latest 155 substances restricted per the REACH Regulation were last updated on June 16, 2014. Please refer to the following for the most current candidate list of substances: <http://echa.europa.eu/candidate-list-table>.



ams Sensors Germany solutions are not designed or intended for use in critical applications, in which the failures or malfunctions of the product may result in personal injury or death. Use of ams Sensors Germany products in life support systems is expressly unauthorized and any use by customer is completely at their own risk. In the case of a restricted use of the product described here, an application of the product outside of this limitation is at your own risk.

Warranty disclaimer – The warranty expressed herein shall be in lieu of any other warranties, expressed or implied, including, without limitation, any implied warranties or conditions of merchantability and fitness for a particular purpose., which are expressly disclaimed, and is in lieu of any and all other obligations or liability on supplier's part- For the avoidance of doubt, supplier shall not be liable for any special, incidental, indirect or consequential loss or damage, including loss of revenue or profit, of any kind of nature, arising at any time, from any cause whatsoever resulting from the use or operation of the products or any breach of this limited warranty.

Legal liability - ams Sensors Germany assumes no responsibility for the use of any foreign products or circuits described in this document or customer product design, conveys no license, either expressed or implied, under any patent or other right, and makes no representation that the foreign circuits are free of patent infringement. ams Sensors Germany further makes no claim as to the suitability of its products for any particular purpose, nor does ams Sensors Germany assume any liability arising out of the use of any product or circuit, and specifically disclaims any and all liability, including without limitation consequential or incidental damages.



ESD Warning: Sensor handling precautions should be observed to avoid static discharge.



WEEE Disposal: - The product should be disposed in to according the Directive 2002/96 / EC of the European Council on Waste Electrical and Electronic Equipment [WEEE] and the German electoral law [ElektroG] of 16 March 2005. Please contact our technical support if you need more details.