

PART NUMBER	REVISION	DESCRIPTION	FEED TYPE
2151528-2	H	FINE CRIMP HEIGHT ADJUST	PNEUMATIC
7-2151528-2	H	PNEUMATIC AND CRIMP TOOLING KIT	PNEUMATIC
7-2151528-7	E	CRIMP TOOLING KIT	-

ATLANTIC VERSION TERMINATOR INTERFACE ADAPTER

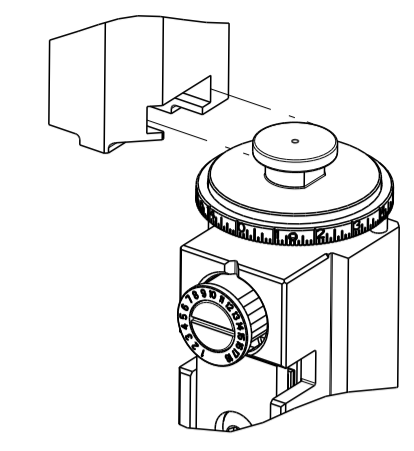

APPLICATOR DATA		
CRIMP	SIZE	TYPE
WIRE	0.64 mm [.025]	F
INSUL	0.61 mm [.024]	F

APPLICATOR INSTRUCTIONS 408-35042

TERMINAL DATA: HIROSE TERMINAL HIROSE CRIMP SPECIFICATION	
TERMINAL NAME: HIROSE TERMINAL	
WIRE STRIP LENGTH	INSULATION DIAMETER RANGE
1.20-1.90 mm [.047-.075 IN]	Ø0.50-0.60 mm [.020-.024 IN]
TERMINAL APPLICATION SPECIFICATION	TAD-P 0506
TERMINALS APPLIED	
TE TERMINAL	HIROSE TERMINAL
1949699-1	DF20F-2830SCFA
1949699-2	DF20B-2830SCFA

WIRE SIZE	CRIMP HEIGHT mm [INCH]	CRIMP HEIGHT REFERENCE SETTING
28 AWG	0.52 +/- 0.02 [.020 +/- .001]	10.3
30 AWG	0.50 +/- 0.02 [.020 +/- .001]	10.4

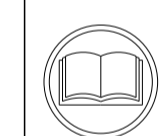

- 1 RECOMMENDED SPARE PARTS
- 2 REFER TO SUPPLIED INSTRUCTION SHEET FOR CLEANING, LUBRICATION AND STORAGE OF APPLICATOR.
- 3 APPLY PART NUMBER 2-23419-6 LOCTITE TO THREADS OF ITEM 242.
- 4 CRIMP HEIGHT REFERENCE SETTING WAS THE SETTING USED WHEN THE APPLICATOR WAS QUALIFIED AT THE FACTORY. ADJUSTMENT MAY BE NECESSARY WHEN RUNNING APPLICATOR IN THE FIELD.
- 5 TERMINAL LUBRICANT IS RECOMMENDED.
- 6 UNLESS SPECIFIED OTHERWISE TORQUE VALUES SHALL BE USED PER DOCUMENT, 101-35000.
- 7 TERMINAL PITCH NOT COMPATIBLE WITH MECHANICAL FEED.

***WARNING**
ON INSTALLATION, SET WIRE DISC TO CRIMP HEIGHT REFERENCE SETTING FOR LARGEST WIRE SIZE. CRIMP HEIGHT REFERENCE SETTINGS GREATER THAN THE VALUE SHOWN MAY CAUSE DAMAGE TO THE CRIMP TOOLING. REFER TO THE INSTRUCTION SHEET FOR PROPER SETUP AND ADJUSTMENTS.

LOC	DIST	REVISIONS					
A	66	P	LTN	DESCRIPTION	DATE	DWN	APVD
		E		ECR-15-017145	01DEC2015	XZ	TE
		F		ECR-19-000285	08JAN2019	TB	TE
		G		ECR-21-112342	01SEP2021	JWC	TE
		H		ECR-22-127694	25JAN2022	RK	GB

-	1	1	2119641-1	FEED CAM, AIR FEED	248
-	1	1	2119082-1	CAM, SNAIL, INSULATION ADJUSTMENT	244
-	1	1	2079764-1	WASHER, WAVE SPRING, CREST-TO-CREST	243
-	1	1	2119083-1	RETAINER, INSULATION DIAL	242
-	1	1	2844940-1	AIR FEED MODULE	238
-	REF	REF	994970-2	COUNTER, MAGNETIC	164
-	1	1	1-22281-8	SPRING, COMPRESSION	121
-	1	1	2119955-1	ASSY, LUBRICATOR, SIDE FEED	113
-	1	1	2844908-1	SCREW, LOCKING	99
-	1	1	2844907-1	POST, LOCKING	98
-	1	1	1-690438-0	FRONT STRIP GUIDE	96
-	2	2	2168083-1	SCR, SKT HD CAP, RoHS, M3 X 8.0	95
-	1	1	2168083-6	SCR, SKT HD CAP, RoHS, M5 X 65	93
-	1	1	1-455888-6	SPACER, CRIMPER	82
-	1	1	1803607-3	DOCUMENTATION PACKAGE	71
-	1	1	1-2119791-4	DEPRESSOR, WIRE	70
-	1	1	2119943-1	WASHER, SPACER	69
-	1	1	2119740-1	TAG, IDENTIFICATION	67
-	2	2	2168078-1	SCREW, DRIVE, RH, RoHS, 2 x .188	66
-	2	2	2-18032-5	SCR, SET, FLT PNT, M5 X 20.0	61
-	1	1	2168083-2	SCR, SKT HD CAP, RoHS, M4 X 8.0	60
-	1	1	1338685-1	PAWL, FEED	56
-	4	4	2168083-3	SCR, SKT HD CAP, RoHS, M4 X 12.0	54
-	1	1	18023-9	SCR, SKT HD CAP M4 X 6.0	49
-	1	1	1803583-9	APPLICATOR BASIC ASSEMBLY, SF	46
-	1	1	1803515-1	RAM ASSEMBLY, SF ATLANTIC	44
-	1	1	1803602-1	SCR, BHSC, RoHS (M8 X 25)	41
-	1	1	2-1752356-6	SUPPORT, TERMINAL	34
-	2	2	2079383-5	SCR, BHSC, RoHS (M4 X 20)	33
-	2	2	2-2844962-1	SPACER, CYLINDRICAL, STRIP GUIDE	30
-	1	1	2-2844938-0	PLATE, STRIP GUIDE	29
-	2	2	22283-1	SPRING, COMPRESSION	27
-	1	1	356835-1	LEVER, DRAG RELEASE	26
-	1	1	240792-1	DRAG, TERMINAL	25
-	1	1	1320928-2	STRIP GUIDE	24
-	1	1	980371-4	SCR, SKT HD SHLDR 5.0 DIA X 6.0	23
-	1	1	2168083-2	SCR, SKT HD CAP, RoHS, M4 X 8.0	21
-	2	2	1-18028-2	WASHER, FLAT, REG M4	20
-	1	1	2119533-1	STRIPPER, SIDE FEED	19
-	1	1	3-22280-3	SPRING, COMPRESSION	12
-	1	1	1-356885-5	STOP, SHEAR	11
-	1	1	2119805-1	SHEAR HOLDER, FRONT	10
-	1	1	1803095-6	FLOATING SHEAR, FRONT	9
-	1	2	1803334-8	ANVIL, COMBINATION	8
-	1	1	1-2119757-9	DEPRESSOR, SHEAR	5
-	1	1	2-238011-0	BLOCK, CRIMPER SPACER	4
-	1	2	1-1803326-2	CRIMPER, INSULATION F	3
-	1	2	1803323-7	CRIMPER, WIRE PREMIUM	1

DIMENSIONS:		TOLERANCES UNLESS OTHERWISE SPECIFIED:		MATERIAL:		FINISH:	
mm	0 PLC ±	1 PLC ±	2 PLC ±	3 PLC ±	4 PLC ±	ANGLES	FINISH

ITEM NO	DESCRIPTION	QTY
-77-72-2	PART NO	
	DESCRIPTION	

DWN	C. MOYER	20OCT2011
CHK	T. ELBIN	20OCT2011
APVD	T. ELBIN	20OCT2011

NAME	Ocean Side Feed Applicator		
SIZE	CAGE CODE	DRAWING NO	RESTRICTED TO
A1	00779	2151528	

Customer Accessible Production Drawing SCALE 1:2 SHEET 1 OF 4 REV H

ATLANTIC VERSION
Shown on sheets 1 of 4 & 2 of 4
(Pacific version shown on sheets 3 of 4 & 4 of 4)

LOC	DIST	REVISIONS					
A	66	P	LTN	DESCRIPTION	DATE	DWN	APVD
		-		SEE SHEET 1	-	-	-

FEED TYPE

PNEUMATIC

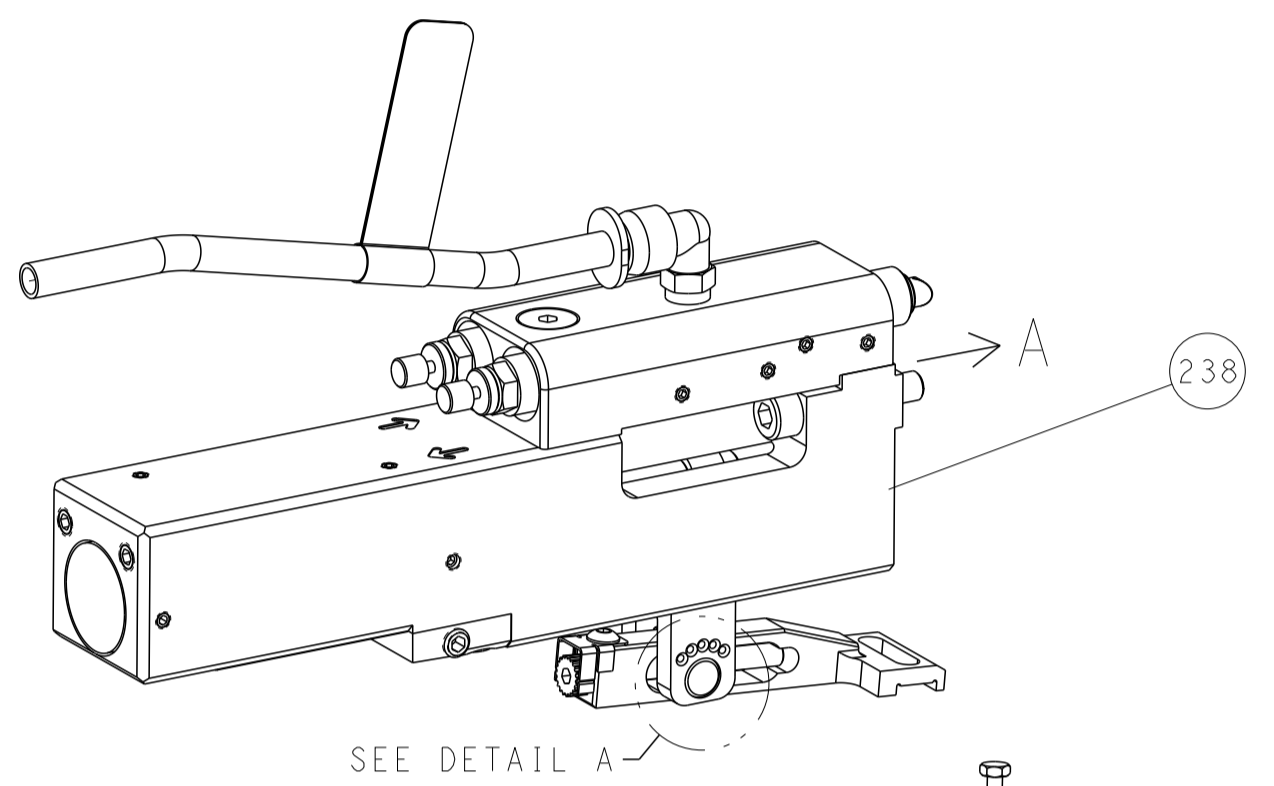

FEED SPRING SETTING POSITION
(SHOWN FROM REAR SIDE)

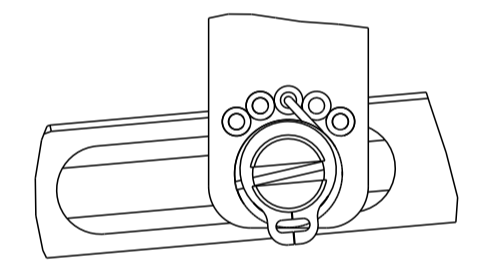

DETAIL A

CAM POSITION

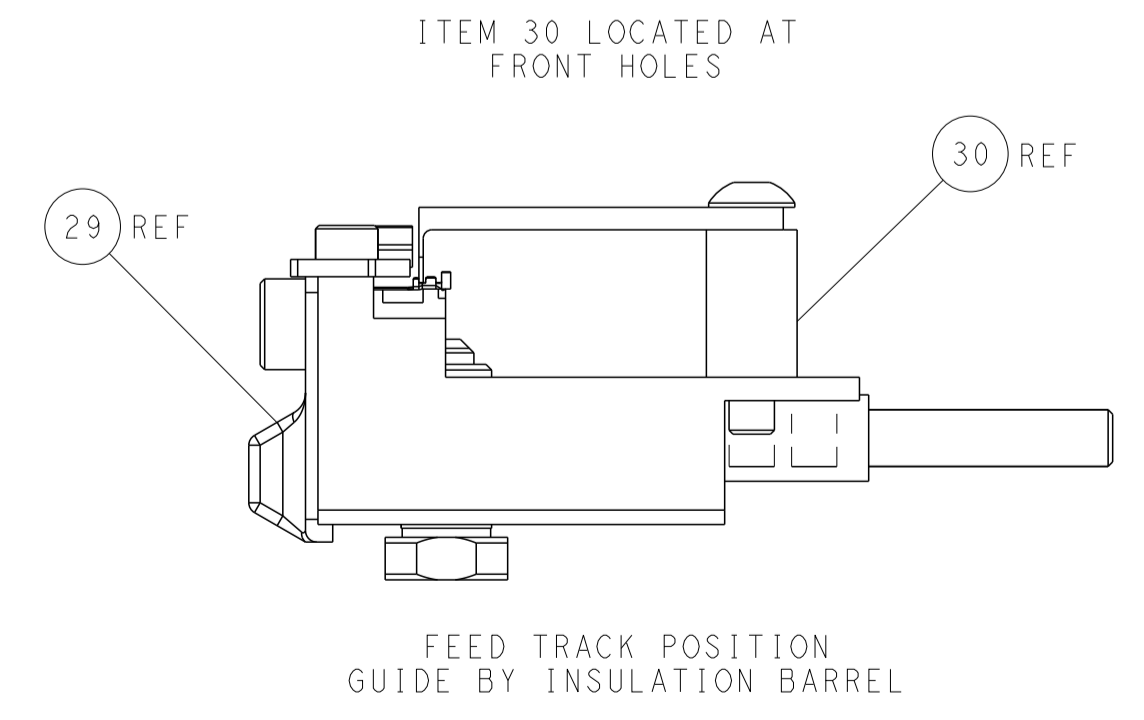
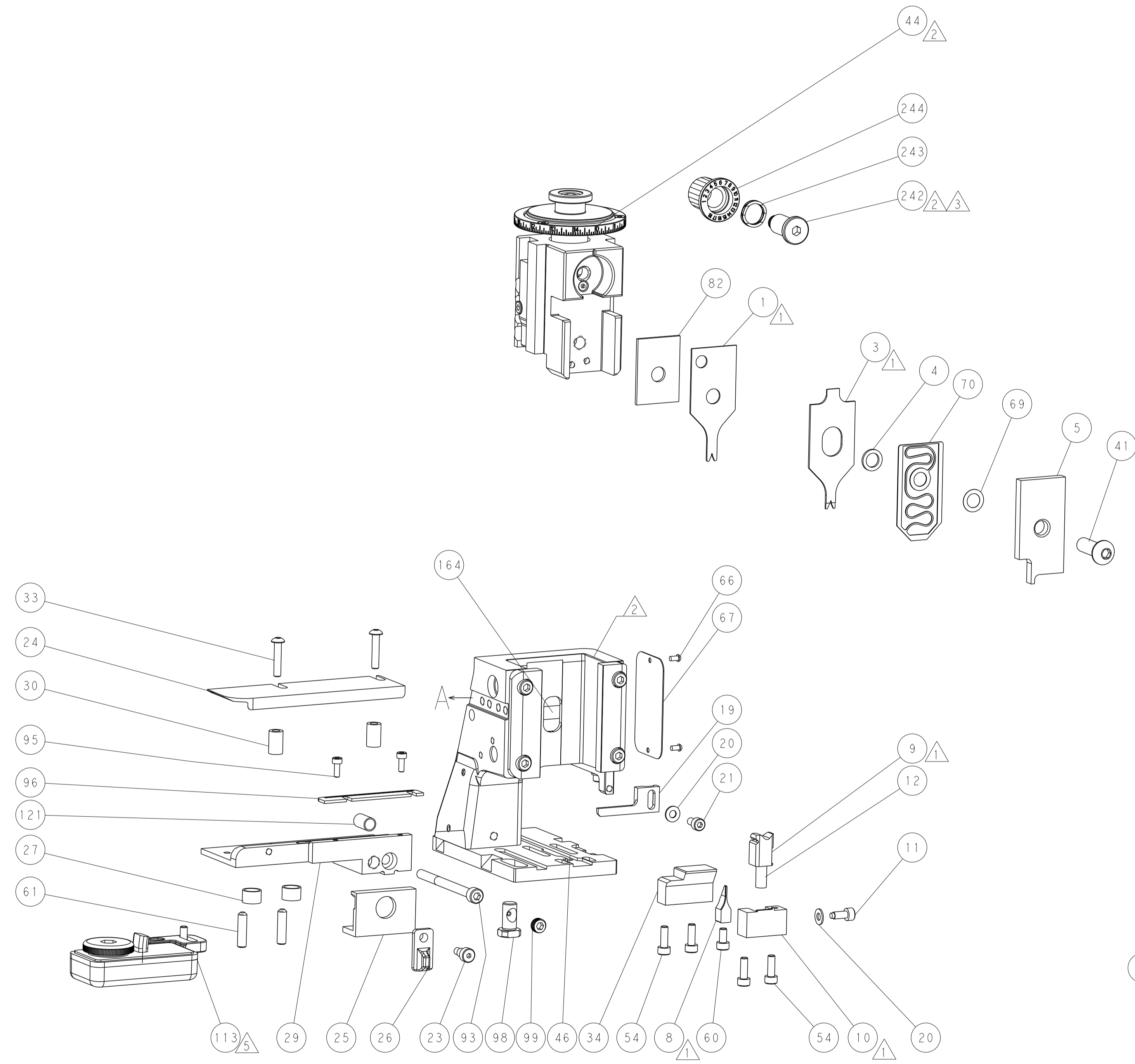
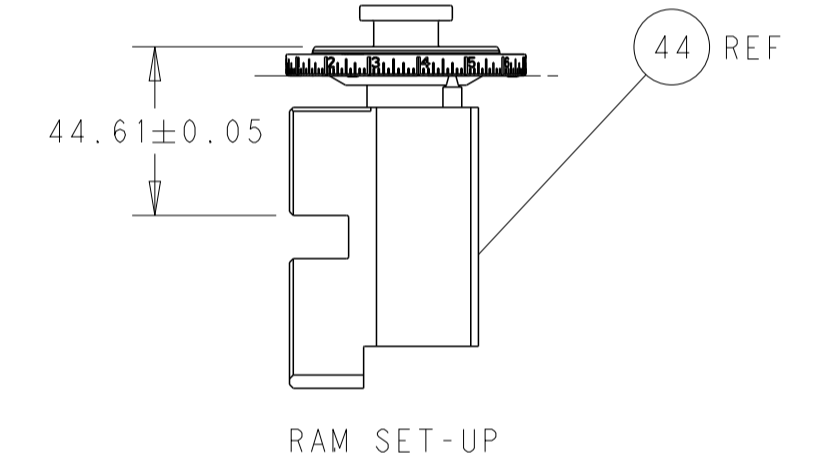
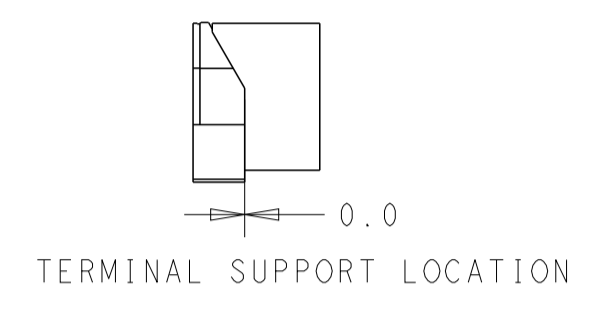
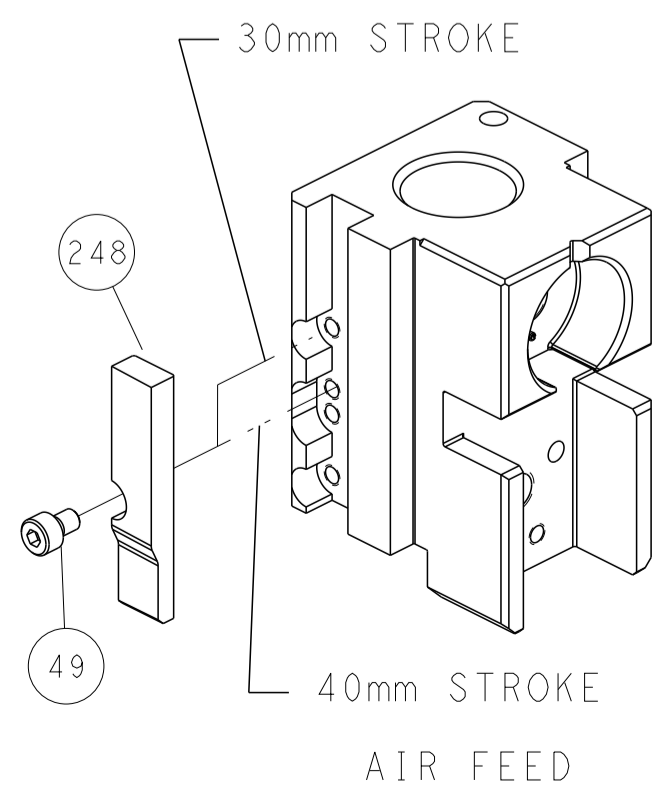

ATLANTIC VERSION
 Shown on sheets 1 of 4 & 2 of 4
 (Pacific version shown on sheets 3 of 4 & 4 of 4)

<small>THIS DRAWING IS UNPUBLISHED. RELEASED FOR PUBLICATION 20. COPYRIGHT 20 BY TYCO ELECTRONICS CORPORATION. ALL RIGHTS RESERVED.</small>		DWN C. MOYER 20OCT2011 CHK T. ELBIN 20OCT2011 APVD T. ELBIN 20OCT2011	STE TE Connectivity Harrisburg, PA 17105-3608
DIMENSIONS: mm TOLERANCES UNLESS OTHERWISE SPECIFIED: 0 PLC ± 1 PLC ± 2 PLC ± 3 PLC ± 4 PLC ± ANGLES ± MATERIAL: - FINISH: -		NAME: Ocean Side Feed Applicator PRODUCT SPEC: APPLICATION SPEC: SIZE: A1 CAGE CODE: 00779 DRAWING NO: 2151528 WEIGHT: - SCALE: 1:2	RESTRICTED TO: - SHEET 1 OF 4 REV H
AMP 4805 REV 31MAR2000		Customer Accessible Production Drawing SHEETS 3 & 4 ARE NOT REQUIRED FOR ATLANTIC VERSION	

PART NUMBER	REVISION	DESCRIPTION	FEED TYPE
2-2151528-2	H	FINE CRIMP HEIGHT ADJUST	PNEUMATIC
7-2151528-7	E	CRIMP TOOLING KIT	-

PACIFIC VERSION TERMINATOR
 INTERFACE ADAPTER

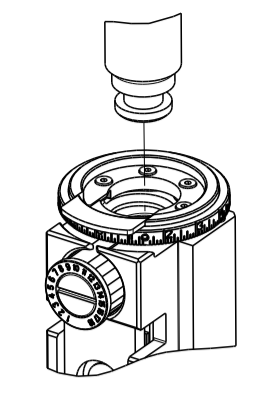

APPLICATOR DATA		
CRIMP	SIZE	TYPE
WIRE	0.64 mm [.025]	F
INSUL	0.61 mm [.024]	F

APPLICATOR INSTRUCTIONS
 408-35042

TERMINAL DATA: HIROSE TERMINAL HIROSE CRIMP SPECIFICATION	
TERMINAL NAME: HIROSE TERMINAL	
WIRE STRIP LENGTH 1.20-1.90 mm [.047-.075 IN]	INSULATION DIAMETER RANGE Ø0.50-0.60 mm [.020-.024 IN]
TERMINAL APPLICATION SPECIFICATION TAD-P 0506	
TERMINALS APPLIED	
TE TERMINAL	HIROSE TERMINAL
1949699-1	DF20F-2830SCFA
1949699-2	DF20B-2830SCFA

WIRE SIZE	CRIMP HEIGHT mm [INCH]	CRIMP HEIGHT REFERENCE SETTING
28 AWG	0.52+/-0.02 [.020+/-0.001]	10.3
30 AWG	0.50+/-0.02 [.020+/-0.001]	10.4



- RECOMMENDED SPARE PARTS
- REFER TO SUPPLIED INSTRUCTION SHEET FOR CLEANING, LUBRICATION AND STORAGE OF APPLICATOR.
- APPLY PART NUMBER 2-23419-6 LOCTITE TO THREADS OF ITEM 242.
- CRIMP HEIGHT REFERENCE SETTING WAS THE SETTING USED WHEN THE APPLICATOR WAS QUALIFIED AT THE FACTORY. ADJUSTMENT MAY BE NECESSARY WHEN RUNNING APPLICATOR IN THE FIELD.
- TERMINAL LUBRICANT IS RECOMMENDED.
- UNLESS SPECIFIED OTHERWISE TORQUE VALUES SHALL BE USED PER DOCUMENT, 101-35000.
- TERMINAL PITCH NOT COMPATIBLE WITH MECHANICAL FEED.

***WARNING**
 ON INSTALLATION, SET WIRE DISC TO CRIMP HEIGHT REFERENCE SETTING FOR LARGEST WIRE SIZE. CRIMP HEIGHT REFERENCE SETTINGS GREATER THAN THE VALUE SHOWN MAY CAUSE DAMAGE TO THE CRIMP TOOLING. REFER TO THE INSTRUCTION SHEET FOR PROPER SETUP AND ADJUSTMENTS.

LOC	DIST	REVISIONS					
		P	LTN	DESCRIPTION	DATE	OWN	APVD
A	66	-	-	SEE SHEET 1	-	-	-

-	1	2119082-1	CAM, SNAIL, INSULATION ADJUSTMENT	244	
-	1	2079764-1	WASHER, WAVE SPRING, CREST-TO-CREST	243	
-	1	2119083-1	RETAINER, INSULATION DIAL	242	
-	1	2844940-1	AIR FEED MODULE	238	
-	REF	994970-2	COUNTER, MAGNETIC	164	
-	1	2119641-2	FEED CAM, AIR FEED	151	
-	1	2168083-8	SCR, SKT HD CAP, RoHS, M4 X 16	144	
-	4	2168083-9	SCR, SKT HD CAP, RoHS, M4 X 20	143	
-	1	1-1803583-0	APPLICATOR BASIC ASSEMBLY, SF	141	
-	1	1803516-1	RAM ASSEMBLY, SF PACIFIC	140	
-	1	1-22281-8	SPRING, COMPRESSION	121	
-	1	2119955-1	ASSY, LUBRICATOR, SIDE FEED	113	
-	1	2844908-1	SCREW, LOCKING	99	
-	1	2844907-1	POST, LOCKING	98	
-	1	1-690438-0	FRONT STRIP GUIDE	96	
-	2	2168083-1	SCR, SKT HD CAP, RoHS, M3 X 8.0	95	
-	1	2168083-6	SCR, SKT HD CAP, RoHS, M5 X 65	93	
-	1	1-455888-6	SPACER, CRIMPER	82	
-	1	1803607-3	DOCUMENTATION PACKAGE	71	
-	1	1-2119791-4	DEPRESSOR, WIRE	70	
-	1	2119943-1	WASHER, SPACER	69	
-	1	2119740-1	TAG, IDENTIFICATION	67	
-	2	2168078-1	SCREW, DRIVE, RH, RoHS, 2 x .188	66	
-	2	2-18032-5	SCR, SET, FLT PNT, M5 X 20.0	61	
-	1	1338685-1	PAWL, FEED	56	
-	1	18023-9	SCR, SKT HD CAP M4 X 6.0	49	
-	1	1803602-1	SCR, BHSC, RoHS (M8 X 25)	41	
-	1	2-1752356-6	SUPPORT, TERMINAL	34	
-	2	2079383-5	SCR, BHSC, RoHS (M4 X 20)	33	
-	2	2-2844962-1	SPACER, CYLINDRICAL, STRIP GUIDE	30	
-	1	2-2844938-0	PLATE, STRIP GUIDE	29	
-	2	22283-1	SPRING, COMPRESSION	27	
-	1	356835-1	LEVER, DRAG RELEASE	26	
-	1	240792-1	DRAG, TERMINAL	25	
-	1	1320928-2	STRIP GUIDE	24	
-	1	980371-4	SCR, SKT HD SHLDR 5.0 DIA X 6.0	23	
-	1	2168083-2	SCR, SKT HD CAP, RoHS, M4 X 8.0	21	
-	2	1-18028-2	WASHER, FLAT, REG M4	20	
-	1	2119533-1	STRIPPER, SIDE FEED	19	
-	1	3-22280-3	SPRING, COMPRESSION	12	
-	1	1-356885-5	STOP, SHEAR	11	
-	1	2119805-1	SHEAR HOLDER, FRONT	10	
-	1	1803095-6	FLOATING SHEAR, FRONT	9	
1	1	1803334-8	ANVIL, COMBINATION	8	
-	1	1-2119757-9	DEPRESSOR, SHEAR	5	
-	1	2-238011-0	BLOCK, CRIMPER SPACER	4	
1	1	1-1803326-2	CRIMPER, INSULATION F	3	
-	1	1803323-7	CRIMPER, WIRE PREMIUM	1	
-	77	-22	PART NO	DESCRIPTION	ITEM NO

PACIFIC VERSION
 Shown on sheets 3 of 4 & 4 of 4
 (Atlantic version shown on sheets 1 of 4 & 2 of 4)

DIMENSIONS: mm 		TOLERANCES UNLESS OTHERWISE SPECIFIED: 0 PLC ± 1 PLC ± 2 PLC ± 3 PLC ± 4 PLC ± ANGLES ° FINISH		DWG: C. MOYER 20OCT2011 CHK: T. ELBIN 20OCT2011 APVD: T. ELBIN 20OCT2011 PRODUCT SPEC APPLICATION SPEC WEIGHT: - SCALE: 1:2 SHEET 1 OF 4 REV H		NAME: Ocean Side Feed Applicator SIZE: A1 CAGE CODE: 00779 DRAWING NO: 2151528 RESTRICTED TO: - Customer Accessible Production Drawing	
-----------------------	--	---	--	--	--	---	--

LOC	DIST	REVISIONS			
P	LTN	DESCRIPTION	DATE	DWN	APVD
-	-	SEE SHEET 1	-	-	-

FEED TYPE PNEUMATIC

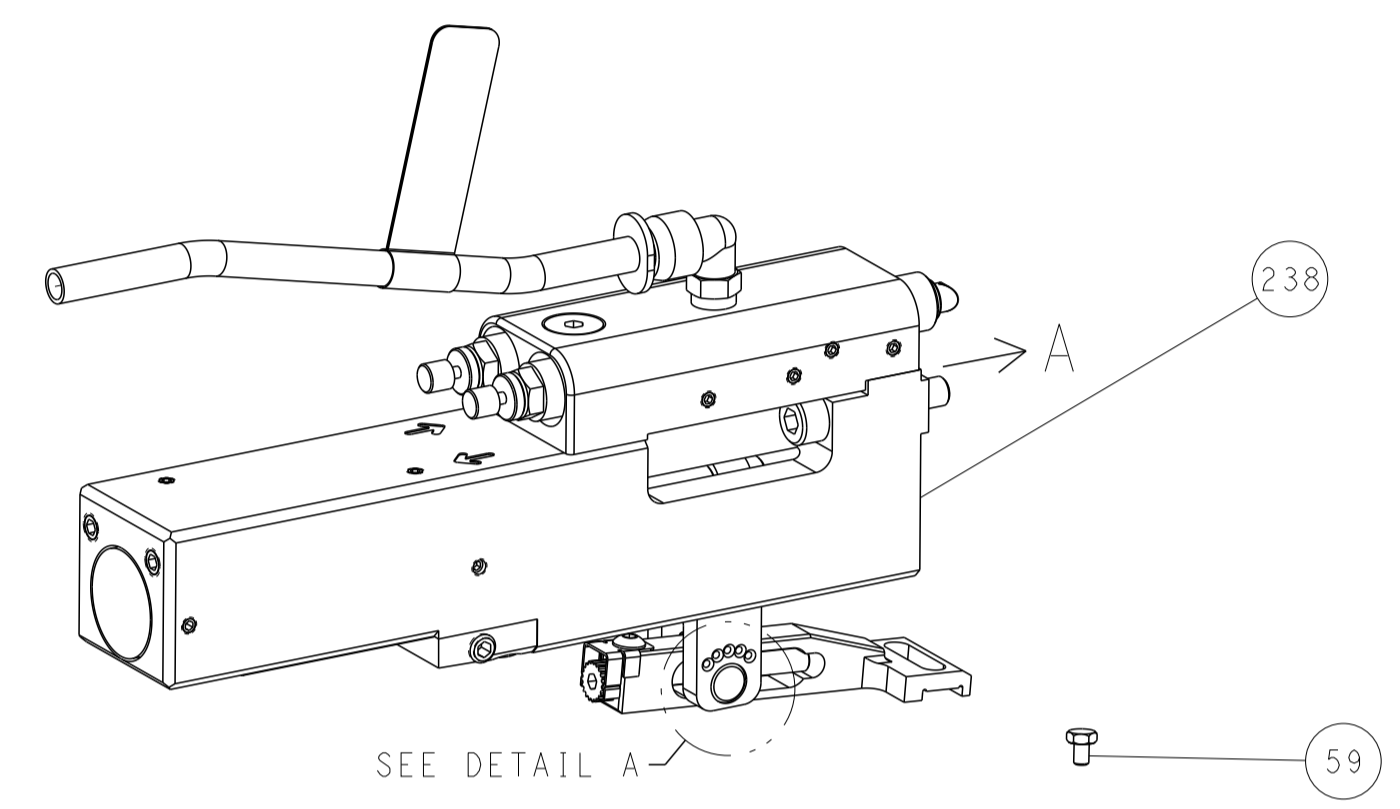

SEE DETAIL A

FEED SPRING SETTING POSITION (SHOWN FROM REAR SIDE)

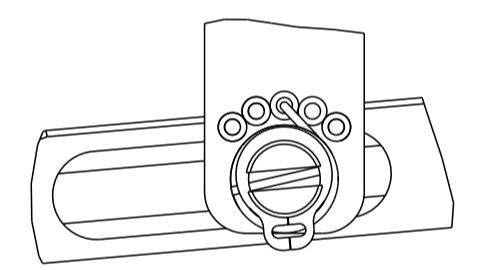

DETAIL A

CAM POSITION

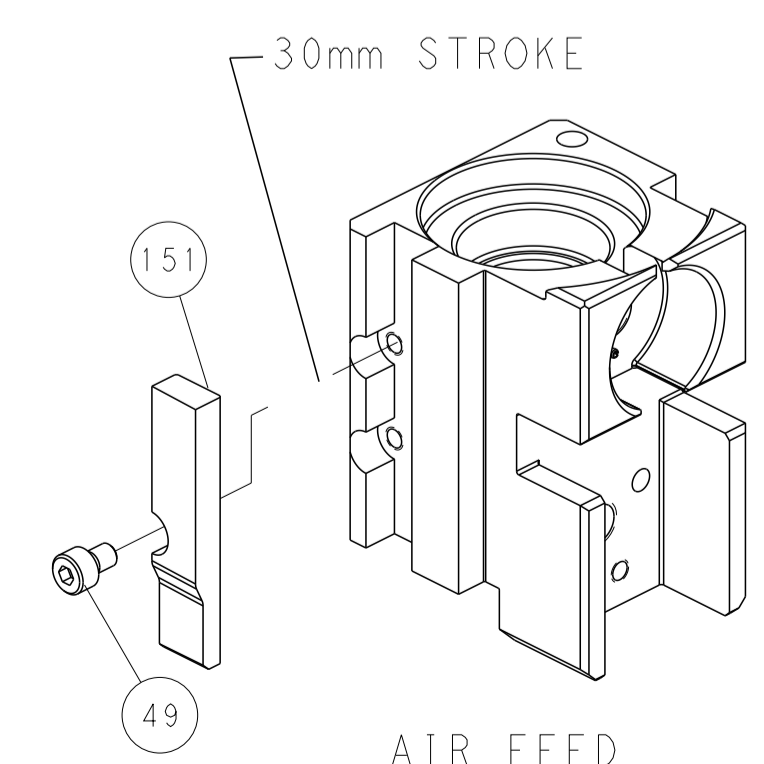

AIR FEED

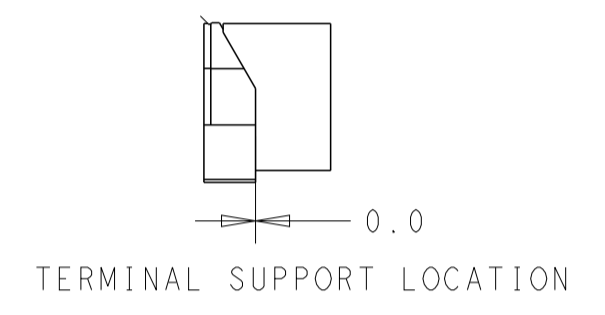
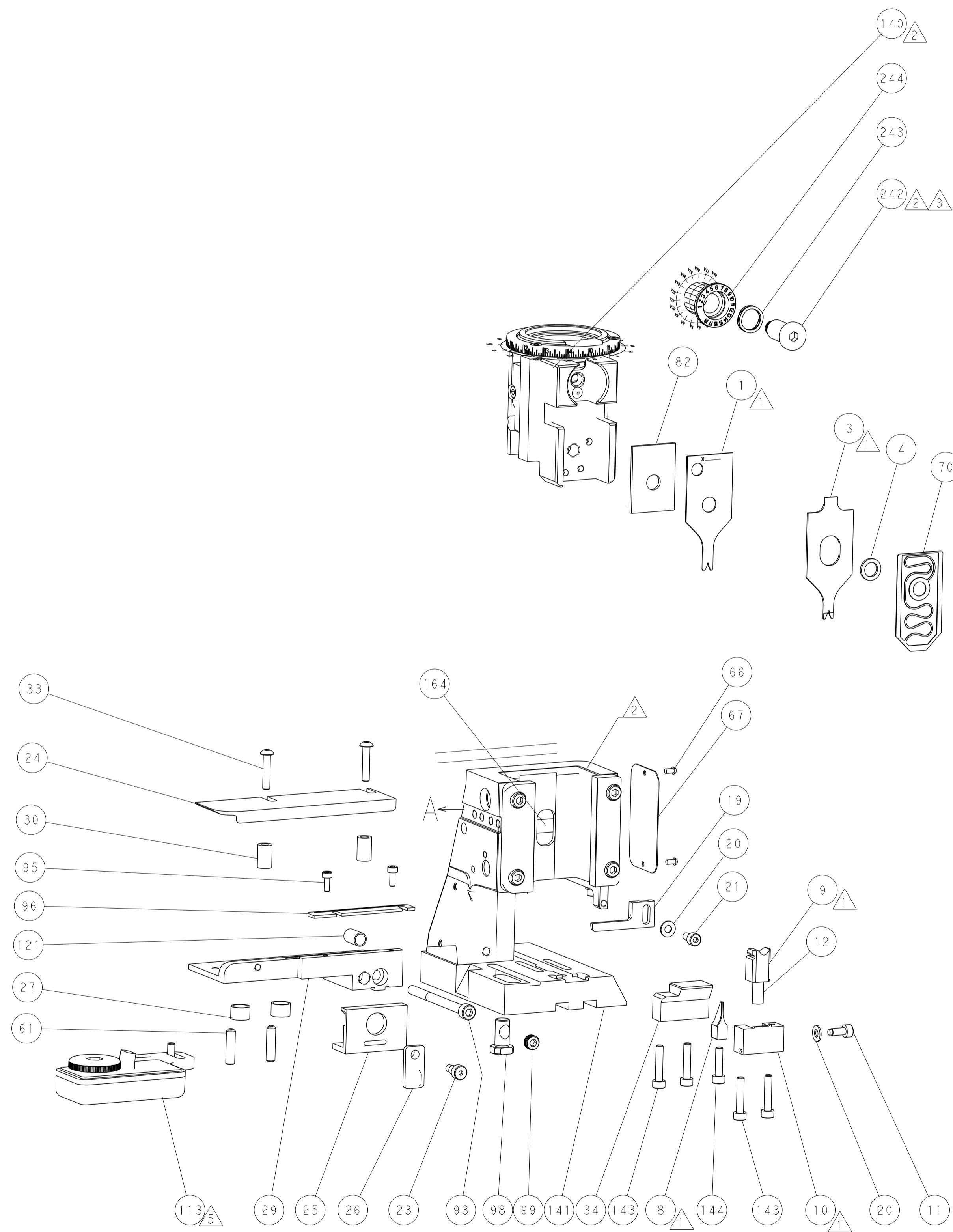

TERMINAL SUPPORT LOCATION

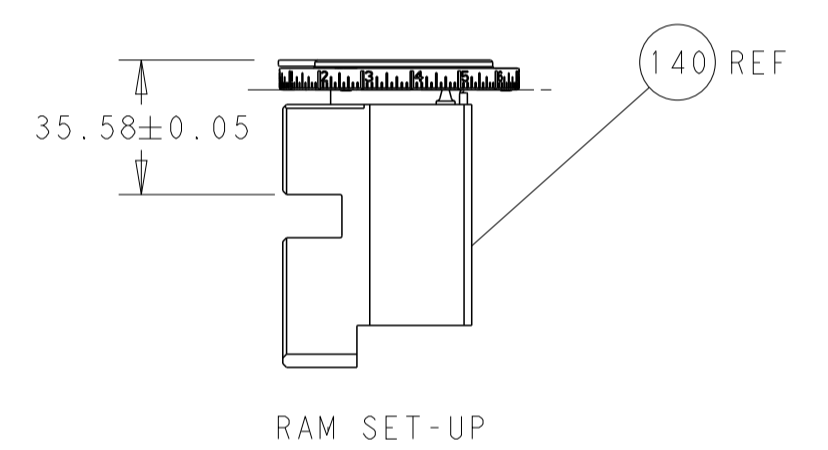

RAM SET-UP

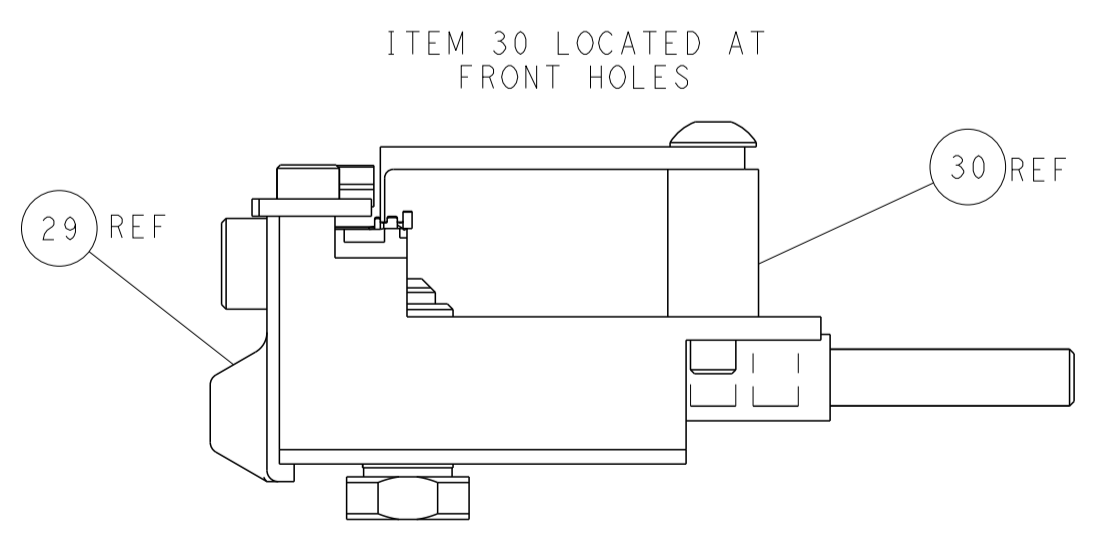

FEED TRACK POSITION
GUIDE BY INSULATION BARREL

PACIFIC VERSION
 Shown on sheets 3 of 4 & 4 of 4
 (Atlantic version shown on sheets 1 of 4 & 2 of 4)

DIMENSIONS:		TOLERANCES UNLESS OTHERWISE SPECIFIED:		DWN C. MOYER 20OCT2011		TE Connectivity	
mm	0 PLC ±	1 PLC ±	2 PLC ±	3 PLC ±	4 PLC ±	5 PLC ±	Harrisburg, PA 17105-3608
MATERIAL:	FINISH:	WEIGHT:	SCALE:	SIZE:	CAGE CODE:	DRAWING NO:	RESTRICTED TO:
			1:2	A1	00779	2151528	
Customer Accessible Production Drawing				SHEET 1 OF 4 REV H			