

Type TCR Series

Key Features

Suitable for laser fine tune

Small size and light weight

Highly reliable multilayer electrode construction

Compatible with all soldering process

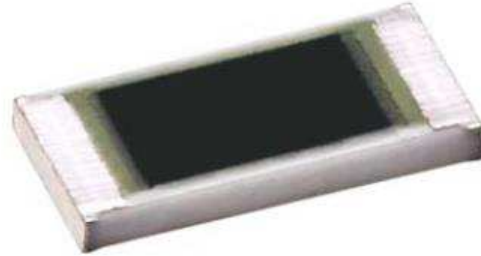

This Ruthenium based trimmable thick film chip resistor, suitable for laser fine tuning is ideal for use in circuits where a variable resistor might otherwise be used.

Applications

Tuner

Mobile Phone

Camcorder

Portable Audio

Photo Sensor

Portable Measuring Equipment

Characteristics – Electrical

Size	Power Rating @70°C	Max. Operating Voltage	Max. Overload Voltage	Tolerance	Resistance Range	TCR (ppm/°C)
0402	0.0625W	50V	100V	+0 ~ -10 +0 ~ -20 +0 ~ -30	1Ω ~ 10MΩ	±200
0603	0.1W	50V	100V		1Ω ~ 9.76 10Ω ~ 1MΩ 1M02 ~ 10MΩ	±200
0805	0.125W	150V	300V			±100
1206	0.25W	200V	400V			±200
1210	0.3W	200V	400V			±100
2010	0.75W	200V	400V			±200
2512	1W	250V	500V			

Operating Temperature range -55 ~ +155°C

Operating Voltage= $V(P \cdot R)$ or Max. operating voltage listed above, whichever is lower.

Overload Voltage= $2.5 \cdot V(P \cdot R)$ or Max. overload voltage listed above, whichever is lower.

Derating

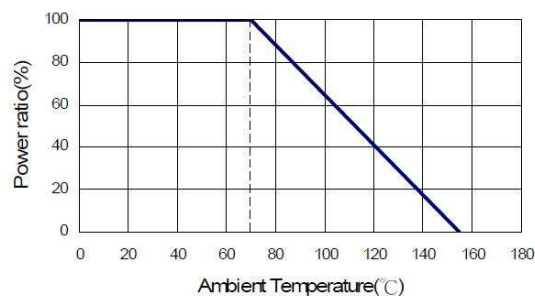

Environmental Characteristics

Item	Requirement	Test Methods
Temperature Coefficient of Resistance (T.C.R.)	As Spec.	JIS-C-5201-1 4.8 IEC-60115-1 4.8 -55°C~+125°C, 25°C is the reference temperature
Short Time Overload	±(1.0%+0.05Ω)	JIS-C-5201-1 4.13 IEC-60115-1 4.13 RCWV*2.5 or Max. Overload Voltage whichever is lower for 5 seconds
Insulation Resistance	≥10G	JIS-C-5201-1 4.6 IEC-60115-1 4.6 Max. Overload Voltage for 1 minute
Endurance	±(2.0%+0.10Ω)	JIS-C-5201-1 4.25 IEC-60115-1 4.25.1 70±2°C, RCWV for 1000 hrs with 1.5 hrs "ON" and 0.5 hr "OFF"
Damp Heat with Load	±(2.0%+0.10Ω)	JIS-C-5201-1 4.24 IEC-60115-1 4.24 40±2°C, 90~95% R.H. RCWV for 1000 hrs with 1.5 hrs "ON" and 0.5 hr "OFF"
Dry Heat	±(1.0%+0.05Ω)	JIS-C-5201-1 4.23 IEC-60115-1 4.23.2 at +125/+155°C for 1000 hrs
Bending Strength	(1.0%+0.05Ω)	JIS-C-5201-1 4.33 IEC-60115-1 4.33 Bending once for 60 seconds 2010, 2512 sizes: 2mm Other sizes: 3mm
Solderability	95% min. coverage	JIS-C-5201-1 4.17 IEC-60115-1 4.17 245±5°C for 3 seconds
Resistance to Soldering Heat	±(0.5%+0.05Ω)	JIS-C-5201-1 4.18 IEC-60115-1 4.18 260±5°C for 10 seconds
Voltage Proof	No breakdown or flashover	JIS-C-5201-1 4.7 IEC-60115-1 4.7 1.42 times Max. Operating Voltage for 1 minute

Environmental Characteristics (cont.)

Item	Requirement	Test Methods
Leaching	Individual leaching area $\leq 5\%$ Total leaching area $\leq 10\%$	JIS-C-5201-1 4.18 IEC-60068-2-58 8.2.1 260±5°C for 30 seconds
Rapid Change of Temperature	$\pm(0.5\%+0.05\Omega)$	JIS-C-5201-1 4.19 IEC-60115-1 4.19 -55°C to +125/+155°C, 5 cycles

RCWV(Rated Continuous Working Voltage)= $\sqrt{P \cdot R}$ or Max. Operating Voltage whichever is lower.

Storage Temperature: 15~28°C; Humidity < 80%RH

Construction and Dimensions

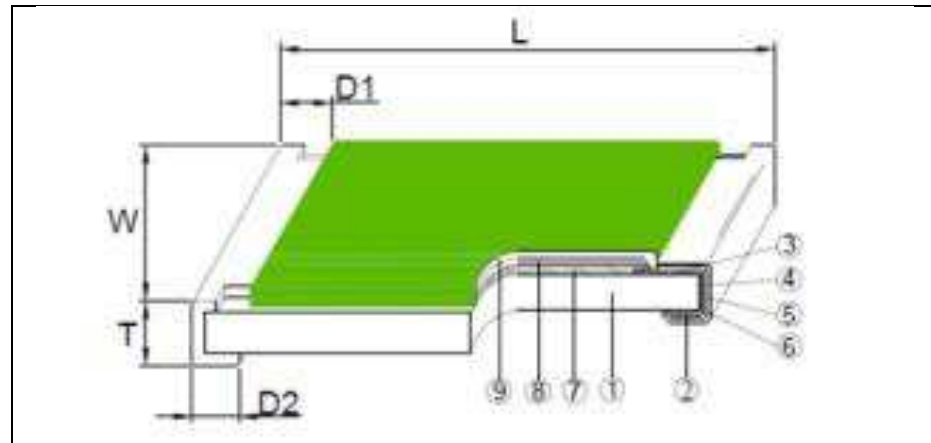

1	Alumina Substrate	4	Edge Electrode	7	Resistor Layer
2	Bottom Electrode	5	Barrier Layer	8	Primary Overcoat
3	Top Electrode	6	External Electrode	9	Secondary Overcoat

Size	L (mm)	W (mm)	T (mm)	D1 (mm)	D2 (mm)	Weight (g) (1000pcs)
0402	1.00±0.05	0.50±0.05	0.35±0.05	0.20±0.10	0.20±0.10	0.62
0603	1.60±0.10	0.80±0.10	0.45±0.10	0.30±0.20	0.30±0.20	2.0
0805	2.00±0.10	1.25±0.10	0.50±0.10	0.35±0.20	0.40±0.20	4.3
1206	3.10±0.10	1.55±0.10	0.55±0.10	0.50±0.25	0.50±0.20	8.9
1210	3.10±0.10	2.60±0.15	0.55±0.10	0.50±0.25	0.50±0.20	15.95
2010	5.00±0.10	2.50±0.15	0.55±0.10	0.60±0.25	0.50±0.20	24.0
2512	6.35±0.10	3.10±0.15	0.55±0.10	0.60±0.25	0.50±0.20	39.4

Soldering Condition (Ref. IPC/JEDEC J-STD-020 & J-STD-002)

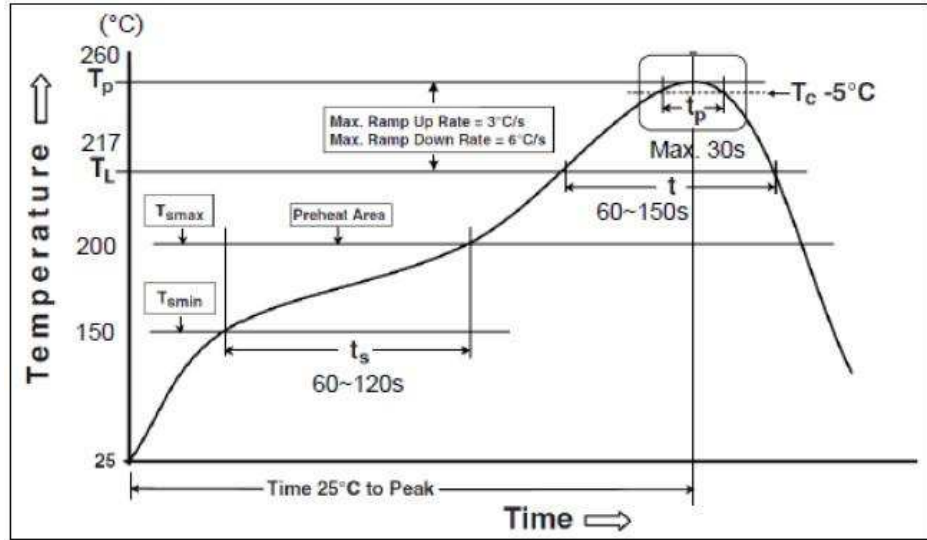

Reflow Profiles	
Profile Feature	Pb-Free Assembly
Preheat	
Min. Temperature (T _{smin})	150°C
Max Temperature (T _{smax})	200°C
Preheating time (t _s) from (T _{smin} to T _{smax})	60 – 120 seconds
Ramp-up rate (T _L to T _p)	3°C/second max.
Liquidous temperature (T _L)	217°C
Time (t _L) maintained above T _L	60 – 150 seconds
Min. Peak temperature (T _p min)	235°C
Max. Peak temperature (T _p max)	260°C
Time (t _p) within 5 °C of the specified classification temperature (T _c)	30 seconds max.
Ramp-down rate (T _p to T _L)	6°C/second max.
Time 25 °C to peak temperature	8 minutes max.

Recommended Land Pattern

Size	Land Pattern Dimensions		
	A (mm)	B (mm)	C (mm)
0402	0.50	0.45	0.60
0603	0.90	0.60	0.90
0805	1.20	0.70	1.30
1206	2.00	0.90	1.60
1210	2.00	0.90	2.80
2010	3.80	0.90	2.80
2512	4.90	1.60	3.50

Packaging

Reel Specification

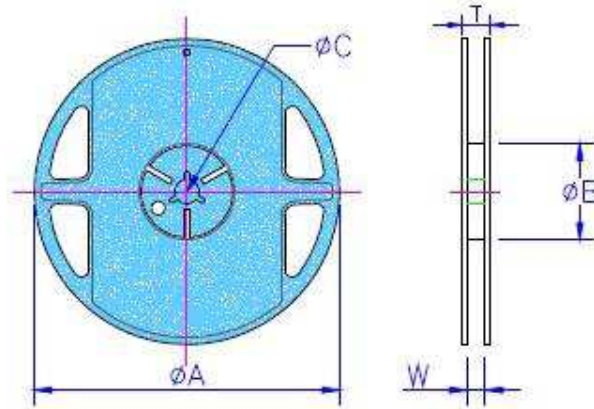

Size	Tape Type	Qty Reel	Tape Width	Reel Nom.	ØA (mm)	ØB (mm)	ØC (mm)	W (mm)	T (mm)
0402	Paper	10K	8mm	7 inch	178.5±1.5	60 ⁺¹ / ₋₀	13.0±0.2	9.0±0.5	12.5±0.5
0603	Paper	5K	8mm	7 inch	178.5±1.5	60 ⁺¹ / ₋₀	13.0±0.2	9.0±0.5	12.5±0.5
0805	Paper	5K	8mm	7 inch	178.5±1.5	60 ⁺¹ / ₋₀	13.0±0.2	9.0±0.5	12.5±0.5
1206	Paper	5K	8mm	7 inch	178.5±1.5	60 ⁺¹ / ₋₀	13.0±0.2	9.0±0.5	12.5±0.5
1210	Paper	5K	8mm	7 inch	178.5±1.5	60 ⁺¹ / ₋₀	13.0±0.2	9.0±0.5	12.5±0.5
2010	Emboss	4K	12mm	7 inch	178.5±1.5	60 ⁺¹ / ₋₀	13.0±0.2	13.0±0.5	15.5±0.5
2512	Plastic	4K	12mm	7 inch	178.5±1.5	60 ⁺¹ / ₋₀	13.0±0.2	13.0±0.5	15.5±0.5

Paper Tape Specification.

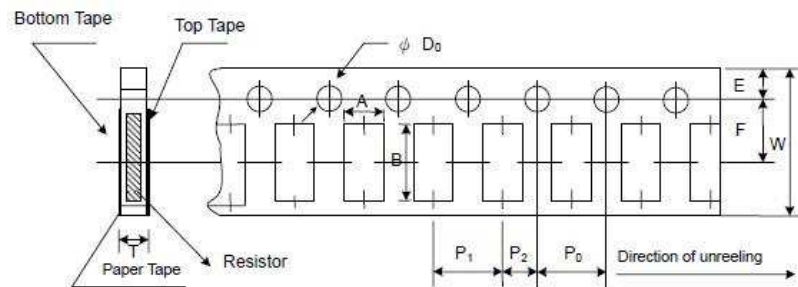

Dimensions (mm)

Size	A ±0.10	B	W ±0.20	E ±0.10	F ±0.05	P ₀ ±0.10	P ₁ ±0.05	P ₂ ±0.05	ØD ₀ +0.1/-0	T ±0.10
0402	0.65	1.15±0.10	8.0	1.75	3.50	4.00	2.00	2.00	1.50	0.45
0603	1.10	1.90±0.10	8.0	1.75	3.50	4.00	4.00	2.00	1.50	0.70
0805	1.60	2.40±0.20	8.0	1.75	3.50	4.00	4.00	2.00	1.50	0.85
1206	1.90	3.50±0.20	8.0	1.75	3.50	4.00	4.00	2.00	1.50	0.85
1210	2.90	3.50±0.20	8.0	1.75	3.50	4.00	4.00	2.00	1.50	0.85

Embossed Plastic Tape Specification

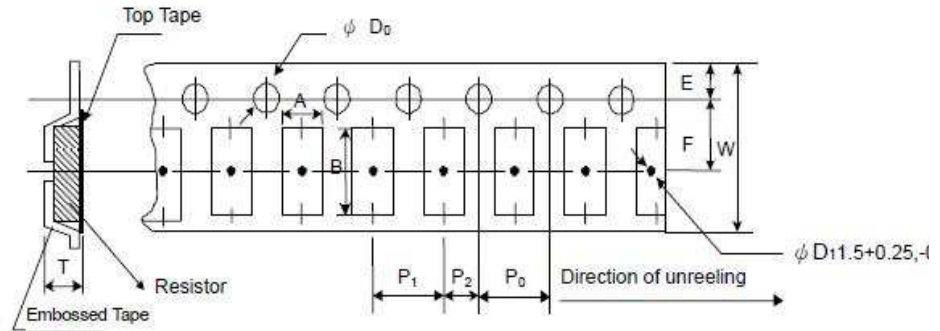

Dimensions (mm)

Size	A	B	W	E	F	P ₀	P ₁	P ₂	∅D ₀	T
2010	±0.10	±0.10	±0.30	±0.10	±0.05	±0.10	±0.10	±0.05	+0.1/-0	±0
2512	3.5	6.7	12.0	1.75	5.5	4.00	4.00	2.00	1.50	1.2

How To Order

TCR	0805	N	1K5
Common Part	Size	Resistance Tolerance	Resistance
TCR	0402	N: 0 ~ -10% P: 0 ~ -20% Q: 0 ~ -30%	1R2: 1.2Ω
	0603		100R: 100Ω
	0805		3K3: 3.3KΩ
	1206		100K: 100KΩ
	1210		1M5: 1.5MΩ
	2010		10M: 10MΩ
	2512		

While TE has made every reasonable effort to ensure the accuracy of the information in this data sheet, TE does not guarantee that it is error-free, nor does TE make any other representation, warranty or guarantee that the information is accurate, correct, reliable or current. TE reserves the right to make any adjustments to the information contained herein at any time without notice. TE expressly disclaims all implied warranties regarding the information contained herein, including, but not limited to, any implied warranties of merchantability or fitness for a particular purpose. The dimensions in this data sheet are for reference purposes only and are subject to change without notice. Specifications are subject to change without notice. Consult TE for the latest dimensions and design specifications.