

- NOTES**
- MATERIAL:**
 CAGE: NICKEL SILVER, THICKNESS: 0.25mm
 CONNECTOR HOUSING: GLASS FILLED LIQUID CRYSTAL POLYMER (LCP), UL 94V-0, COLOR: BLACK
 OVERMOLD TERMINAL HOUSING: GLASS FILLED LIQUID CRYSTAL POLYMER (LCP), UL 94V-0, COLOR: BLACK
 TERMINALS: TIN BRASS
 EMI GASKET: CONDUCTIVE ELASTOMER
 LIGHTPIPE HOUSING: ZINC
 LIGHTPIPES: POLYCARBONATE, COLOR: CLEAR
 - FINISHES:**
 TERMINALS: CONTACT AREA - 0.76 MICROMETERS MINIMUM HARD GOLD OVER 1.27 MICROMETERS MINIMUM NICKEL.
 COMPLIANT TAIL - 0.76 TO 1.52 MICROMETERS MATTE TIN OVER 0.76 MICROMETERS MINIMUM NICKEL.
 LIGHTPIPE HOUSING: 80 MICROMETERS MINIMUM NICKEL OVER COPPER
 - REFER TO PS-75310-001 PRODUCT SPEC FOR ALL ELECTRICAL, MECHANICAL, AND ENVIRONMENTAL SPECIFICATIONS.
 - LIGHTPIPE PAD LAYOUT IS FOR 0805 LOW-PROFILE LED PACKAGE. FOR OTHER RECOMMENDED LAYOUTS REFER TO MOLEX'S REPORT TS-75310-001.
 - REFER TO PK-75450-001 FOR ALL PACKAGING SPECIFICATIONS.
 - THE SURFACES CONFORM TO THE MOLEX COSMETIC SPEC PS-45499-002. ALL EXTERIOR SURFACES TO BE CLASS "B" SURFACE EXCEPT THE UNDERSIDE (CLASS "C") OF THE CAGE (SIDE TOWARD THE PCB) AND AS OTHERWISE NOTED.
 - THE OVERALL CAGE WIDTH AT THE VERTICAL CENTER OF THE FRONT EDGE WILL FALL WITHIN THIS DIMENSION: 57.80+/-0.30 MM. THIS PORTION OF THE CAGE WILL FLEX INWARD AS THE CAGE IS BEING INSERTED INTO THE BEZEL OPENING.
 - REFER TO AS-76090-001 FOR HIGH SPEED ROUTING RECOMMENDATIONS.
 - DATE CODE LOCATION IS SHOWN ABOVE.
 DATE CODE FORMAT: DDDY MX A1
 DDD = DAY OF THE YEAR
 Y = YEAR
 MX = MOLEX
 A = ALPHA CHARACTER - INDICATES MANUFACTURING LINE
 1 = NUMERIC CHARACTER - INDICATES PRODUCTION SHIFT

ENHANCED EMI VERSION

PART NUMBER	LIGHTPIPE CONFIGURATION (SEE VIEWS ON SHEET 2)
760467101	4 LIGHT PORTS
	INNER 2 PORTS
	OUTER 2 PORTS

INITIAL RELEASE EC NO: UCP2015-2383 DRWN:BBARKER 2014/12/09 CHKD:TIBARRA 2014/12/09 APPR:SMILLER 2015/03/17	QUALITY SYMBOLS ▽=0 ▽=0 ▽=0	GENERAL TOLERANCES (UNLESS SPECIFIED)		DIMENSION STYLE MM ONLY		SCALE 3:1	DESIGN UNITS METRIC	THIRD ANGLE PROJECTION		
		4 PLACES ± --- ± ---	mm	INCH	DRAWN BY	DATE	STACKED SFP+ 2X4 ASS'Y W/ METAL EMI GASKET AND LIGHTPIPES, ENHANCED EMI			
		3 PLACES ± --- ± ---			BBARKER	2014/12/09				
		2 PLACES ± 0.13 ± ---			CHECKED BY	DATE	molex			
1 PLACE ± 0.25 ± ---			APPROVED BY	DATE						
0 PLACE ± ±			SMILLER	2015/03/17	MATERIAL NO. SEE TABLE		DOCUMENT NO. RSD-76046-0003	SHEET NO. 1 OF 5		
DRAFT WHERE APPLICABLE MUST REMAIN WITHIN DIMENSIONS		ANGULAR ± 5 °		THIS DRAWING CONTAINS INFORMATION THAT IS PROPRIETARY TO MOLEX INCORPORATED AND SHOULD NOT BE USED WITHOUT WRITTEN PERMISSION						

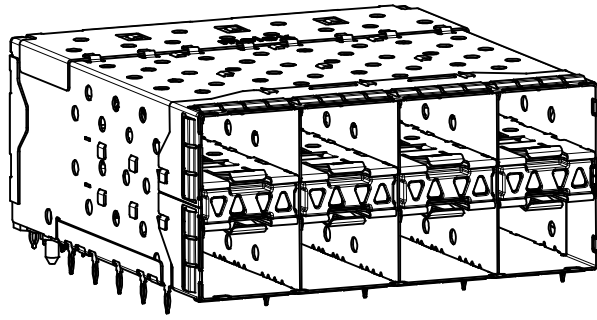

760467101
WITH INNER AND OUTER LIGHTPIPES

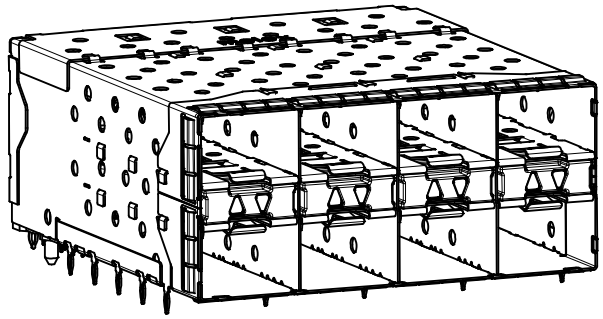

WITH INNER LIGHTPIPES

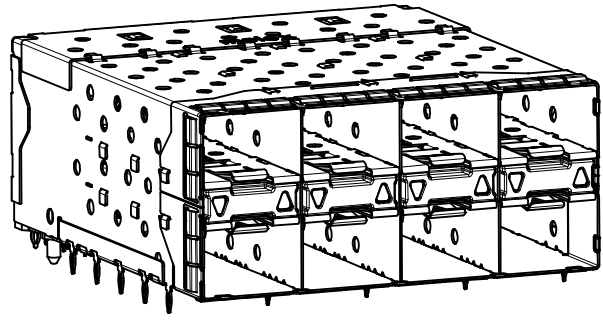

WITH OUTER LIGHTPIPES

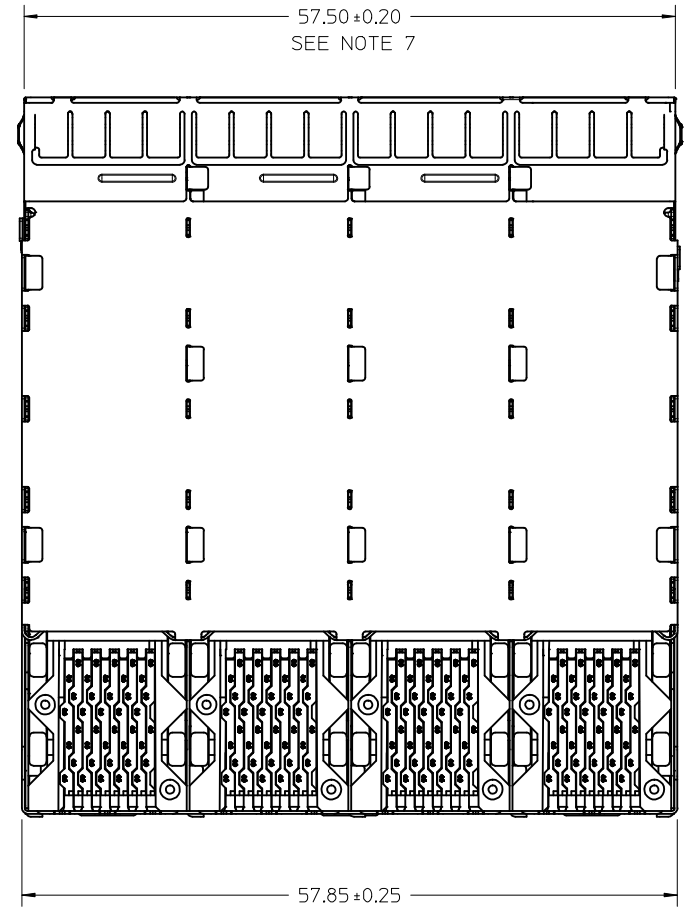

SEE SHEET 1 EC NO: UCP2015-2383 DRWN:BBARKER 2014/12/09 CHKD:TIBARRA 2014/12/09 APPR:SMILLER 2015/03/17	QUALITY SYMBOLS	GENERAL TOLERANCES (UNLESS SPECIFIED)		DIMENSION STYLE	SCALE	DESIGN UNITS	THIRD ANGLE PROJECTION	
	▽=0	mm	INCH	MM ONLY	3:1	METRIC		
	▽=0	4 PLACES ± ---	± ---	DRAWN BY	DATE	TITLE		
	▽=0	3 PLACES ± ---	± ---	BBARKER	2014/12/09	STACKED SFP+ 2X4 ASS'Y W/ METAL EMI GASKET AND LIGHTPIPES, ENHANCED EMI		
	▽=0	2 PLACES ± 0.13	± ---	CHECKED BY	DATE	molex DOCUMENT NO. RSD-76046-0003 SHEET NO. 2 OF 5		
	1 PLACE ± 0.25	± ---	SMILLER	2015/03/17				
	0 PLACE ±	±	APPROVED BY		DATE			
			ANGULAR ± 5 °		MATERIAL NO.			
			DRAFT WHERE APPLICABLE MUST REMAIN WITHIN DIMENSIONS		SEE TABLE			
					SIZE C		THIS DRAWING CONTAINS INFORMATION THAT IS PROPRIETARY TO MOLEX INCORPORATED AND SHOULD NOT BE USED WITHOUT WRITTEN PERMISSION	

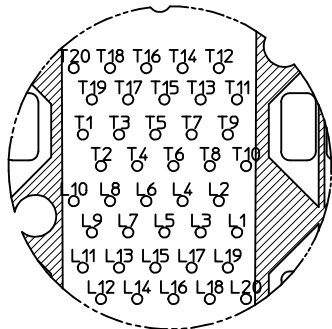

CIRCUIT NUMBERING
COMPONENT SIDE OF BOARD
SCALE 6:1

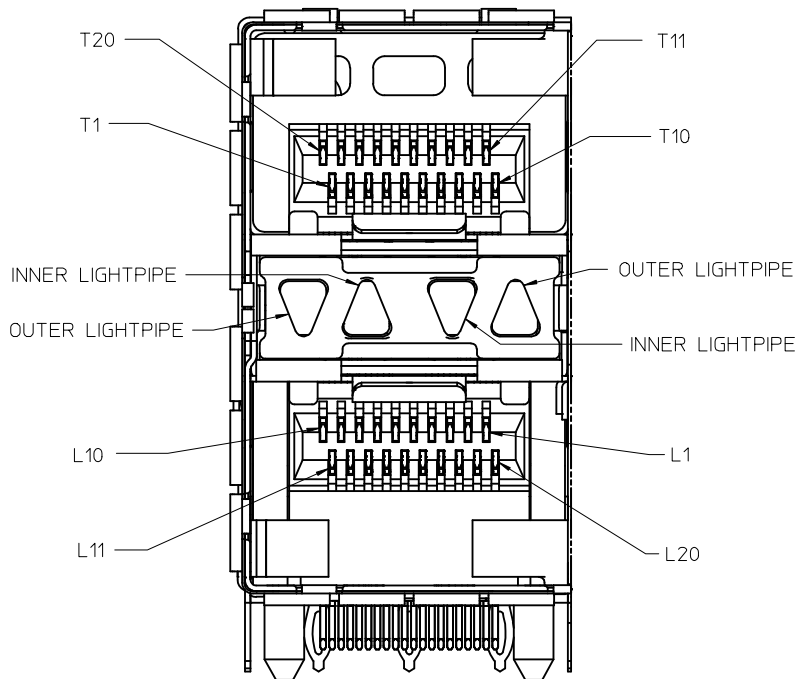

DETAIL A
SCALE 6:1
CIRCUIT NUMBERING
AND LIGHTPIPE
IDENTIFICATION

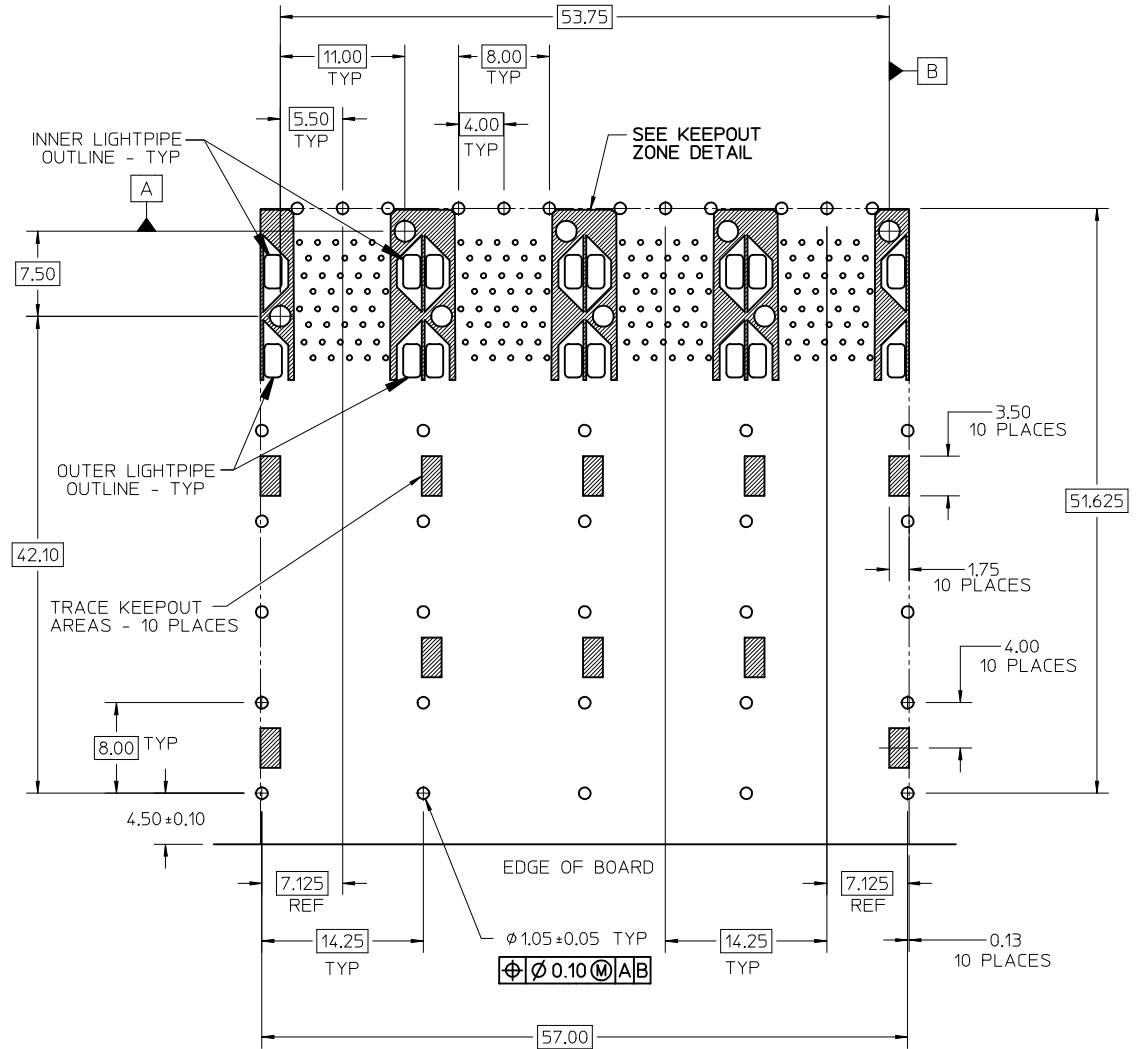

RECOMMENDED PCB LAYOUT - COMPONENT SIDE
RECOMMENDED PCB THICKNESS - 2.36 MM (.093 INCH)

THE ENTIRE AREA OF THE CONNECTOR FOOTPRINT
TO BE CONSIDERED THE KEEP OUT AREA FOR COMPONENTS
(OTHER THAN THE LIGHTPIPE LED'S)
THIS AREA IS INDICATED BY THE DASHED LINE

SEE SHEET 1 EC NO: UCP2015-2383 DRWN:BBARKER 2014/12/09 CHKD:TIBARRA 2014/12/09 APPR:SMILLER 2015/03/17	QUALITY SYMBOLS	GENERAL TOLERANCES (UNLESS SPECIFIED)	DIMENSION STYLE MM ONLY	SCALE 3:1	DESIGN UNITS METRIC	THIRD ANGLE PROJECTION
	▽=0	mm INCH	DRAWN BY DATE BBARKER 2014/12/09	TITLE STACKED SFP+ 2X4 ASS'Y W/ METAL EMI GASKET AND LIGHTPIPES, ENHANCED EMI	molex	SHEET NO. 3 OF 5
	▽=0	4 PLACES ± --- ± --- 3 PLACES ± --- ± --- 2 PLACES ± 0.13 ± --- 1 PLACE ± 0.25 ± --- 0 PLACE ± ±	CHECKED BY DATE	APPROVED BY DATE SMILLER 2015/03/17		
	▽=0	ANGULAR ± 5 °	MATERIAL NO.	SEE TABLE	THIS DRAWING CONTAINS INFORMATION THAT IS PROPRIETARY TO MOLEX INCORPORATED AND SHOULD NOT BE USED WITHOUT WRITTEN PERMISSION	
REV	DESCRIPTION	DRAFT WHERE APPLICABLE MUST REMAIN WITHIN DIMENSIONS	SIZE C			

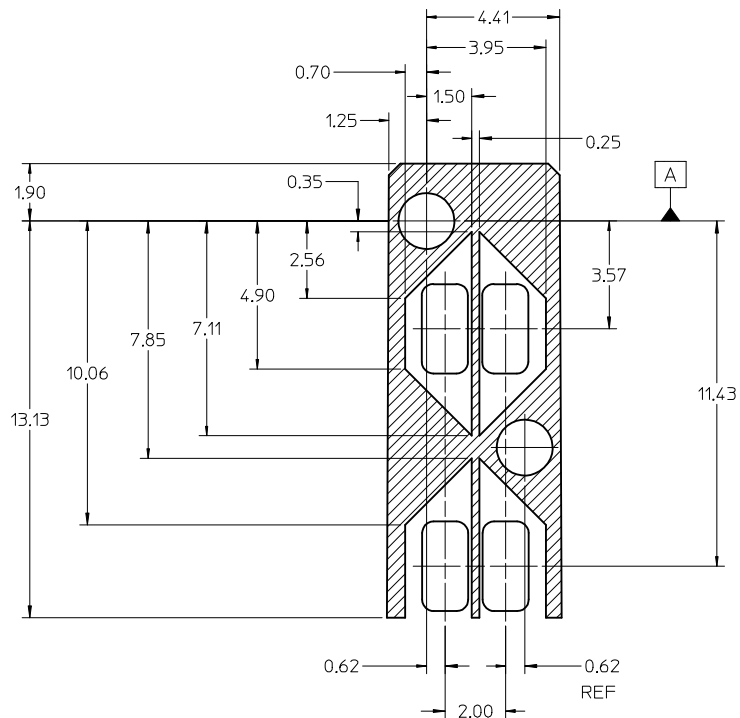

KEEPOUT ZONE DETAIL - LIGHTPIPE LOCATION AND OTHER ZONES
SCALE 8:1

THE HATCHED AREA IN THIS VIEW INDICATES ZONES THAT ARE OCCUPIED BY THE PLASTIC HOUSING THAT SEATS AGAINST THE PCB AND BY THE VERTICAL METAL CAGE WALL THAT STOPS JUST SHORT OF THE PCB

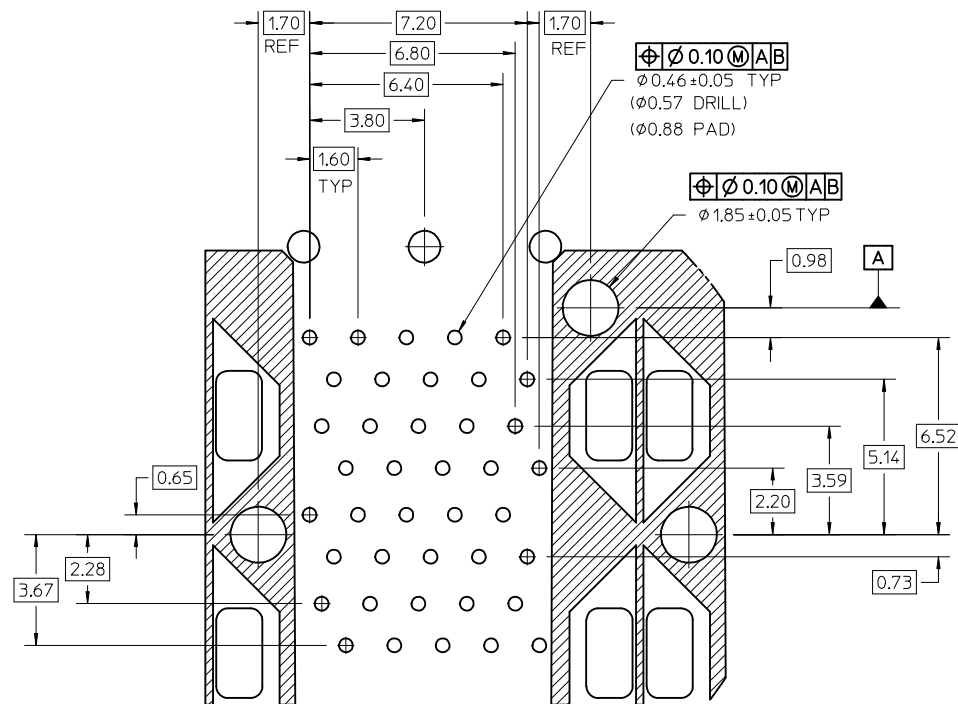

DETAIL B
SCALE 8:1

SEE SHEET 1 EC NO: UCP2015-2383 DRAWN BY: BBARKER 2014/12/09 CHKD: TIBARRA 2014/12/09 APPR: SMILLER 2015/03/17	QUALITY SYMBOLS ▽=0 ▽=0 ▽=0	GENERAL TOLERANCES (UNLESS SPECIFIED)		DIMENSION STYLE MM ONLY		SCALE 8:1	DESIGN UNITS METRIC	THIRD ANGLE PROJECTION	
		4 PLACES ± --- ± ---	3 PLACES ± --- ± ---	2 PLACES ± 0.13 ± ---	1 PLACE ± 0.25 ± ---	0 PLACE ± ±	ANGULAR ± 5 °	DRAWN BY: BBARKER 2014/12/09 DATE: 2014/12/09 CHECKED BY: DATE: 2015/03/17 APPROVED BY: SMILLER 2015/03/17 DATE: 2015/03/17	
A	REV	DRAFT WHERE APPLICABLE MUST REMAIN WITHIN DIMENSIONS		SIZE C		MATERIAL NO. SEE TABLE		DOCUMENT NO. RSD-76046-0003	
THIS DRAWING CONTAINS INFORMATION THAT IS PROPRIETARY TO MOLEX INCORPORATED AND SHOULD NOT BE USED WITHOUT WRITTEN PERMISSION								SHEET NO. 4 OF 5	

13 12 11 10 9 8 7 6 5 4 3 2 1

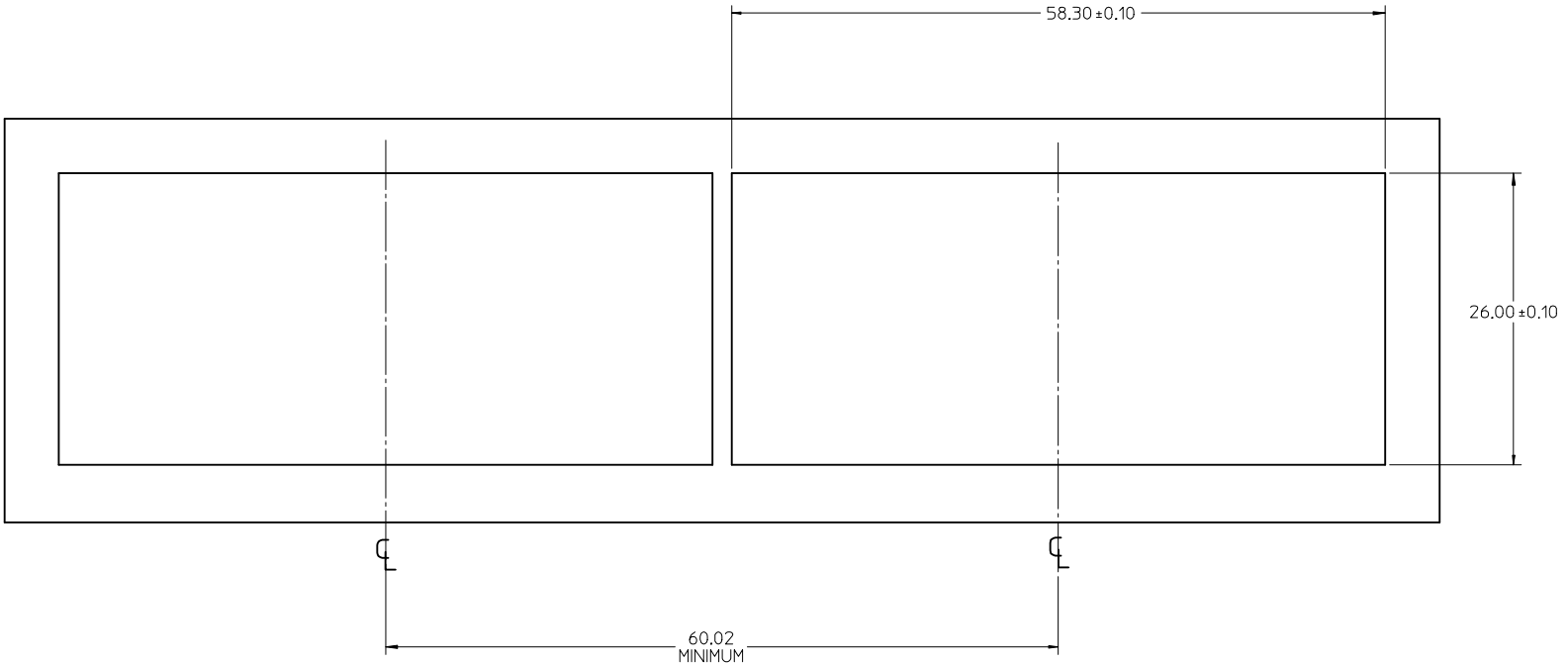

BEZEL CUTOUT CENTER SPACING DETAIL
BEZEL THICKNESS 0.8-2.6

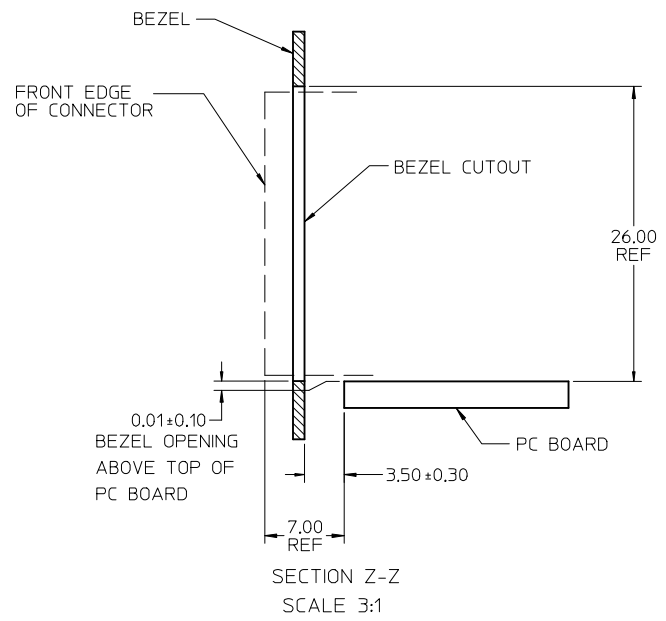

SEE SHEET 1 EC NO: UCP2015-2383 DRWN:BBARKER 2014/12/09 CHKD:TIBARRA 2014/12/09 APPR:SMILLER 2015/03/17	QUALITY SYMBOLS	GENERAL TOLERANCES (UNLESS SPECIFIED)	DIMENSION STYLE	SCALE	DESIGN UNITS	THIRD ANGLE PROJECTION
	▽=0	mm INCH	MM ONLY	3:1	METRIC	☉
	▽=0	4 PLACES ± --- ± ---	DRAWN BY DATE	TITLE		
	▽=0	3 PLACES ± --- ± ---	BBARKER 2014/12/09	STACKED SFP+ 2X4 ASS'Y W/ METAL EMI GASKET AND LIGHTPIPES, ENHANCED EMI		
REV	DESCRIPTION	2 PLACES ± 0.13 ± ---	CHECKED BY DATE	APPROVED BY DATE		
A		1 PLACE ± 0.25 ± ---	SMILLER 2015/03/17	SMILLER 2015/03/17		
		0 PLACE ± ±	MATERIAL NO.		DOCUMENT NO.	SHEET NO.
		ANGULAR ± 5 °	SEE TABLE		RSD-76046-0003	5 OF 5
		DRAFT WHERE APPLICABLE MUST REMAIN WITHIN DIMENSIONS	THIS DRAWING CONTAINS INFORMATION THAT IS PROPRIETARY TO MOLEX INCORPORATED AND SHOULD NOT BE USED WITHOUT WRITTEN PERMISSION			

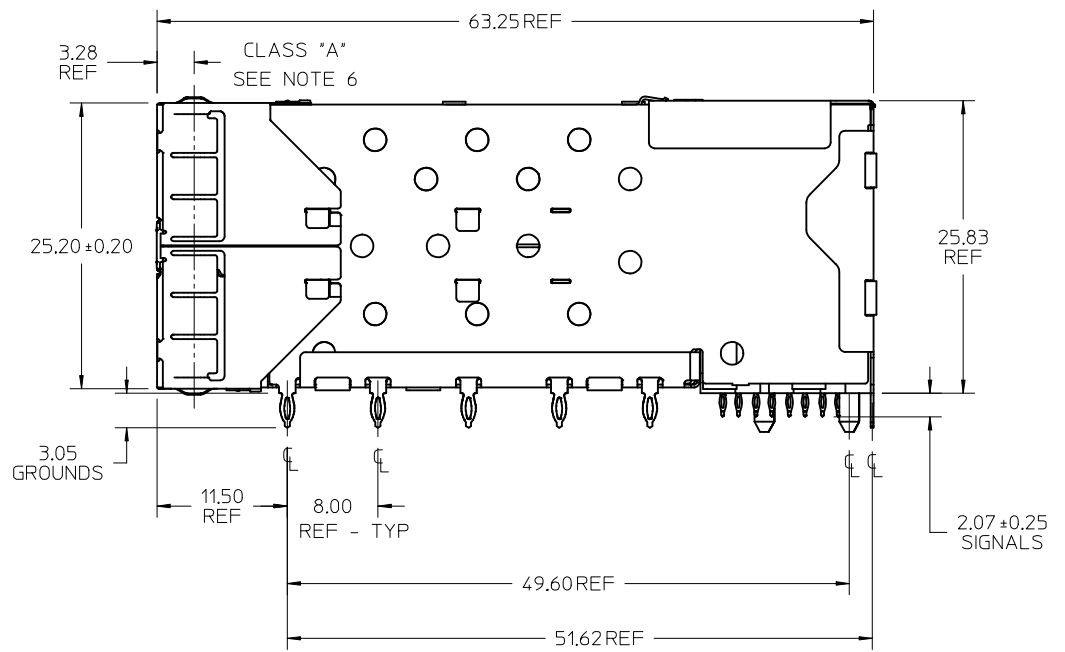
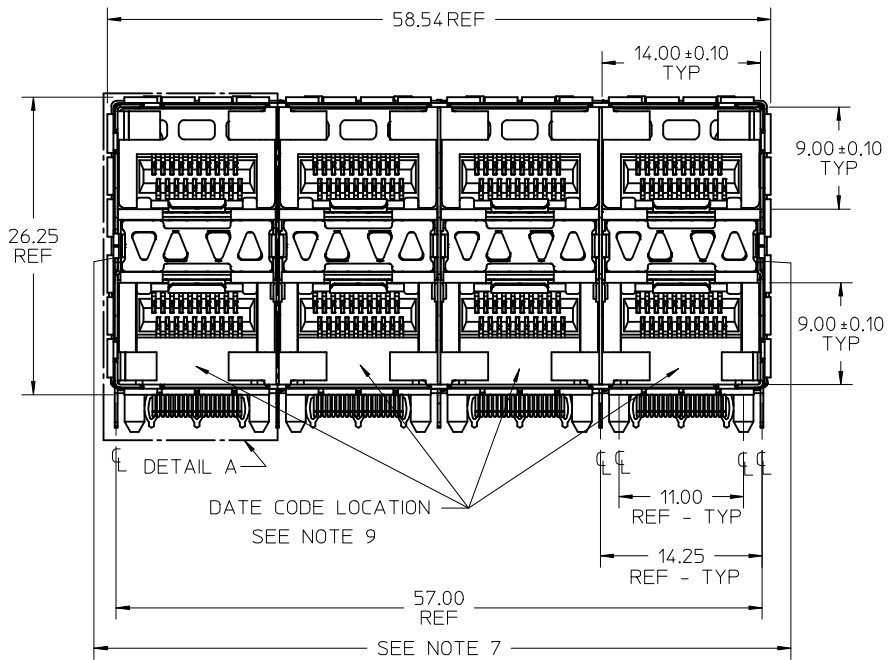

NOTES

- MATERIAL:**
 CAGE: NICKEL SILVER, THICKNESS: 0.25mm
 CONNECTOR HOUSING: GLASS FILLED LIQUID CRYSTAL POLYMER (LCP), UL 94V-0, COLOR: BLACK
 OVERMOLD TERMINAL HOUSING: GLASS FILLED LIQUID CRYSTAL POLYMER (LCP), UL 94V-0, COLOR: BLACK
 TERMINALS: TIN BRASS
 EMI GASKET: PHOS-BRONZE
 LIGHTPIPE HOUSING: ZINC
 LIGHTPIPES: POLYCARBONATE, COLOR: CLEAR
- FINISHES:**
 TERMINALS: CONTACT AREA - 0.76 MICROMETERS MINIMUM HARD GOLD OVER 1.27 MICROMETERS MINIMUM NICKEL.
 COMPLIANT TAIL - 0.76 TO 1.52 MICROMETERS MATTE TIN OVER 0.76 MICROMETERS MINIMUM NICKEL.
 LIGHTPIPE HOUSING: 80 MICROMETERS MINIMUM NICKEL OVER COPPER
 EMI GASKET: 2.54 MICROMETERS MINIMUM NICKEL OVERALL
- REFER TO PS-75310-001 PRODUCT SPEC FOR ALL ELECTRICAL, MECHANICAL, AND ENVIRONMENTAL SPECIFICATIONS.
- LIGHTPIPE PAD LAYOUT IS FOR 0805 LOW-PROFILE LED PACKAGE, FOR OTHER RECOMMENDED LAYOUTS REFER TO MOLEX'S REPORT TS-75310-001.
- REFER TO PK-75450-001 FOR ALL PACKAGING SPECIFICATIONS.
- THE SURFACES CONFORM TO THE MOLEX COSMETIC SPEC PS-45499-002. ALL EXTERIOR SURFACES TO BE CLASS "B" SURFACE EXCEPT THE UNDERSIDE (CLASS "C") OF THE CAGE (SIDE TOWARD THE PCB) AND AS OTHERWISE NOTED.
- THE OVERALL CAGE WIDTH AT THE VERTICAL CENTER OF THE FRONT EDGE WILL FALL WITHIN THIS DIMENSION: 57.80+/-0.30 MM. THIS PORTION OF THE CAGE WILL FLEX INWARD AS THE CAGE IS BEING INSERTED INTO THE BEZEL OPENING.
- REFER TO AS-76090-001 FOR HIGH SPEED ROUTING RECOMMENDATIONS.
- DATE CODE LOCATION IS SHOWN ABOVE.
 DATE CODE FORMAT: DDDY MX A1
 DDD = DAY OF THE YEAR
 Y = YEAR
 MX = MOLEX
 A = ALPHA CHARACTER - INDICATES MANUFACTURING LINE
 1 = NUMERIC CHARACTER - INDICATES PRODUCTION SHIFT

ENHANCED EMI VERSION

PART NUMBER	LIGHTPIPE CONFIGURATION (SEE VIEWS ON SHEET 2)
760467001	4 LIGHT PORTS
760467002	INNER 2 PORTS
760467006	OUTER 2 PORTS - SPECIAL CONFIGURATION

REV. NOTES &2 FOR EMI EC NO: UCP2016-3489 DRW:VANG01 2016/03/07 CHKD:BBARKER 2016/03/07 APPR:SMILLER 2016/03/25	QUALITY SYMBOLS ▽=0 ▽=0 ▽=0	GENERAL TOLERANCES (UNLESS SPECIFIED) <table border="1"> <tr> <th>mm</th> <th>INCH</th> </tr> <tr> <td>4 PLACES ± ---</td> <td>± ---</td> </tr> <tr> <td>3 PLACES ± ---</td> <td>± ---</td> </tr> <tr> <td>2 PLACES ± 0.13</td> <td>± ---</td> </tr> <tr> <td>1 PLACE ± 0.25</td> <td>± ---</td> </tr> <tr> <td>0 PLACE ±</td> <td>±</td> </tr> </table>	mm	INCH	4 PLACES ± ---	± ---	3 PLACES ± ---	± ---	2 PLACES ± 0.13	± ---	1 PLACE ± 0.25	± ---	0 PLACE ±	±	DIMENSION STYLE MM ONLY DRAWN BY DATE TIBARRA 2012/08/09 CHECKED BY DATE BBARKER 2012/08/15 APPROVED BY DATE SMILLER 2012/08/28	SCALE 3:1 DESIGN UNITS METRIC THIRD ANGLE PROJECTION	STACKED SFP+ 2X4 ASS'Y W/ METAL EMI GASKET AND LIGHTPIPES, ENHANCED EMI DOCUMENT NO. SD-76046-0003 SHEET NO. 1 OF 5
		mm	INCH														
		4 PLACES ± ---	± ---														
		3 PLACES ± ---	± ---														
2 PLACES ± 0.13	± ---																
1 PLACE ± 0.25	± ---																
0 PLACE ±	±																
ANGULAR ± 5 °		MATERIAL NO.	DRAFT WHERE APPLICABLE MUST REMAIN WITHIN DIMENSIONS														
SEE TABLE		THIS DRAWING CONTAINS INFORMATION THAT IS PROPRIETARY TO MOLEX INCORPORATED AND SHOULD NOT BE USED WITHOUT WRITTEN PERMISSION															
SIZE C		THIS DRAWING CONTAINS INFORMATION THAT IS PROPRIETARY TO MOLEX INCORPORATED AND SHOULD NOT BE USED WITHOUT WRITTEN PERMISSION															

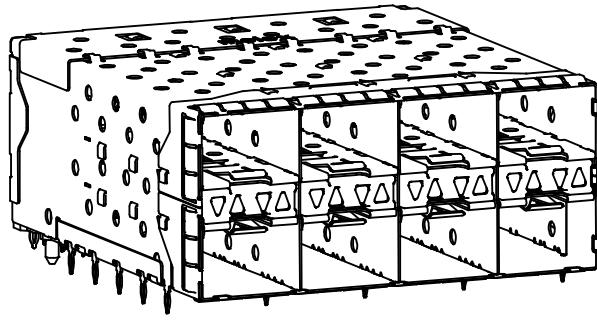

760467001
WITH INNER AND OUTER LIGHTPIPES

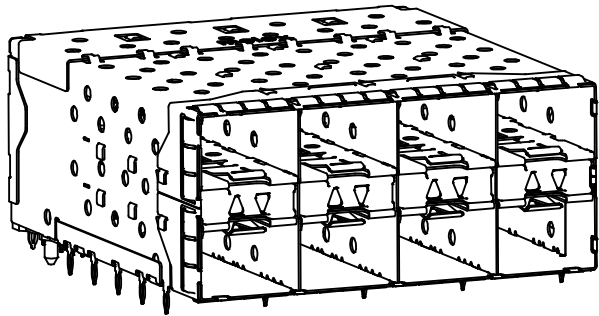

76046-7002
WITH INNER LIGHTPIPES

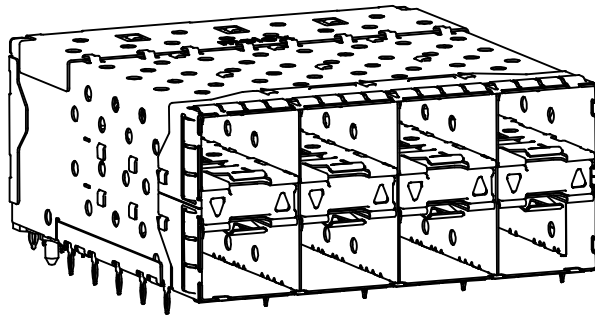

WITH OUTER LIGHTPIPES

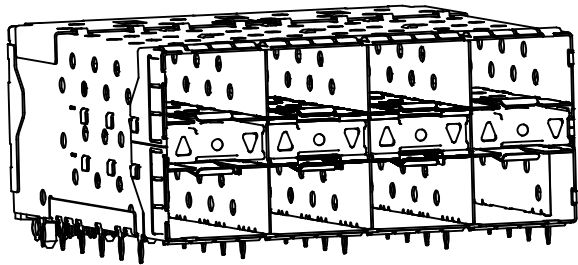

760467006
WITH OUTER LIGHTPIPES
SPECIAL CONFIGURATION

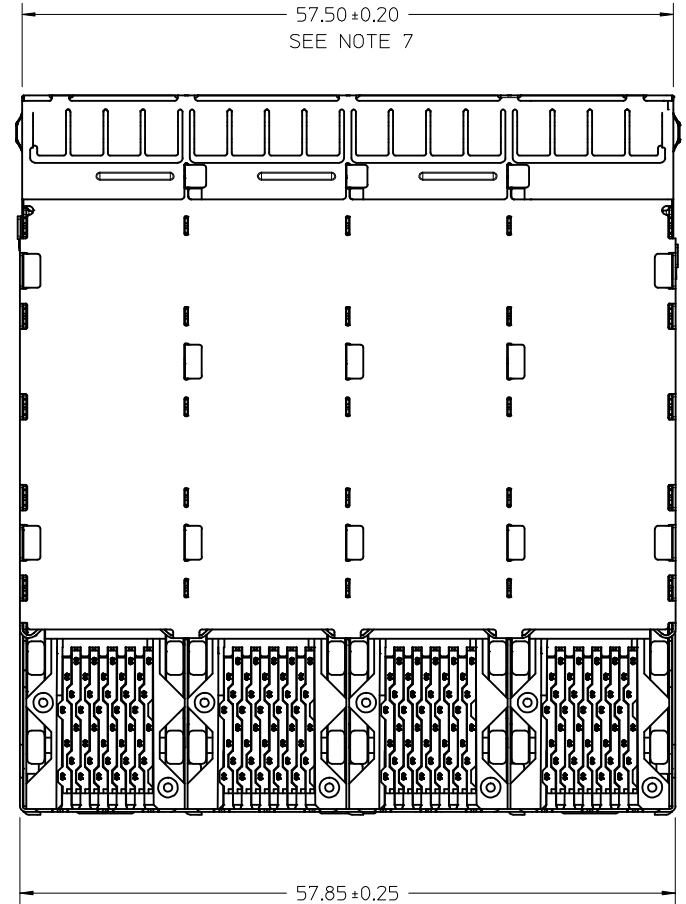

SEE SHEET 1 EC NO: UCP2016-3489 DRWNS:YANG01 2016/03/07 CHKD:BBARKER 2016/03/07 APPR:SMILLER 2016/03/25	QUALITY SYMBOLS ▽=0 ▽=0 ▽=0	GENERAL TOLERANCES (UNLESS SPECIFIED)		DIMENSION STYLE MM ONLY		SCALE 3:1	DESIGN UNITS METRIC	THIRD ANGLE PROJECTION	
		4 PLACES ± --- ± --- 3 PLACES ± --- ± --- 2 PLACES ± 0.13 ± --- 1 PLACE ± 0.25 ± --- 0 PLACE ± ±	mm INCH ± --- ± --- ± --- ± --- ± --- ± --- ± ±	DRAWN BY TIBARRA	DATE 2012/08/09	TITLE STACKED SFP+ 2X4 ASS'Y W/ METAL EMI GASKET AND LIGHTPIPES, ENHANCED EMI		DOCUMENT NO. SD-76046-0003	
ANGLAR ± 5 °		DRAFT WHERE APPLICABLE MUST REMAIN WITHIN DIMENSIONS		SEE TABLE		THIS DRAWING CONTAINS INFORMATION THAT IS PROPRIETARY TO MOLEX INCORPORATED AND SHOULD NOT BE USED WITHOUT WRITTEN PERMISSION			

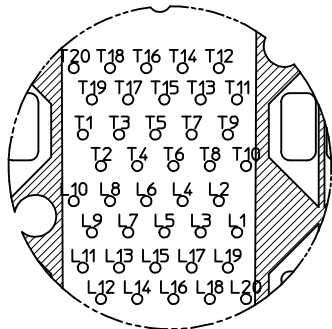

CIRCUIT NUMBERING
COMPONENT SIDE OF BOARD
SCALE 6:1

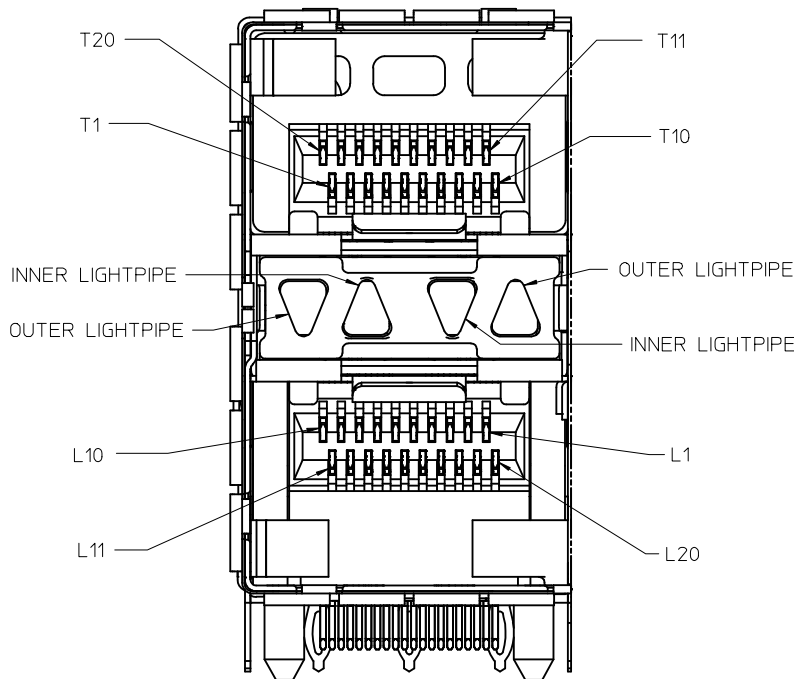

DETAIL A
SCALE 6:1
CIRCUIT NUMBERING
AND LIGHTPIPE
IDENTIFICATION

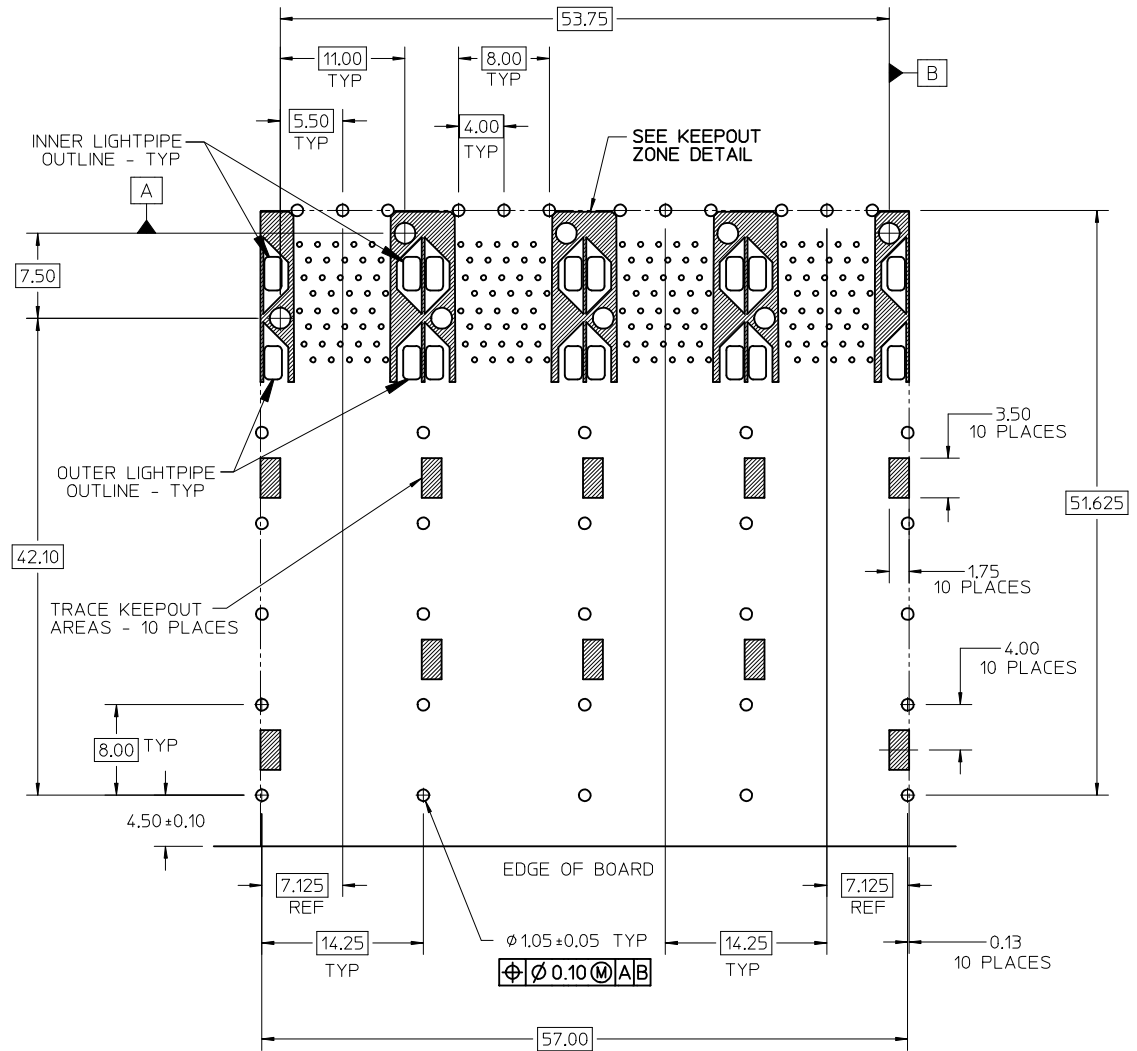

RECOMMENDED PCB LAYOUT - COMPONENT SIDE
RECOMMENDED PCB THICKNESS - 2.36 MM (.093 INCH)

THE ENTIRE AREA OF THE CONNECTOR FOOTPRINT
TO BE CONSIDERED THE KEEP OUT AREA FOR COMPONENTS
(OTHER THAN THE LIGHTPIPE LED'S)
THIS AREA IS INDICATED BY THE DASHED LINE

SEE SHEET 1 EC NO: UCP2016-3489 DRWNSVANG01 2016/03/07 CHKD:BBARKER 2016/03/07 APPR:SMILLER 2016/03/25	QUALITY SYMBOLS	GENERAL TOLERANCES (UNLESS SPECIFIED)	DIMENSION STYLE MM ONLY	SCALE 3:1	DESIGN UNITS METRIC	THIRD ANGLE PROJECTION
	▽=0	mm INCH	DRAWN BY DATE TIBARRA 2012/08/09	TITLE	STACKED SFP+ 2X4 ASS'Y W/ METAL EMI GASKET AND LIGHTPIPES, ENHANCED EMI	molex
	▽=0	4 PLACES ± --- ± ---	CHECKED BY DATE BBARKER 2012/08/15	DOCUMENT NO.		
	▽=0	3 PLACES ± --- ± ---	APPROVED BY DATE SMILLER 2012/08/28	SD-76046-0003		
▽=0	2 PLACES ± 0.13 ± ---	MATERIAL NO.	SHEET NO.			
		1 PLACE ± 0.25 ± ---	SEE TABLE			3 OF 5
		0 PLACE ± ±	SIZE C	THIS DRAWING CONTAINS INFORMATION THAT IS PROPRIETARY TO MOLEX INCORPORATED AND SHOULD NOT BE USED WITHOUT WRITTEN PERMISSION		

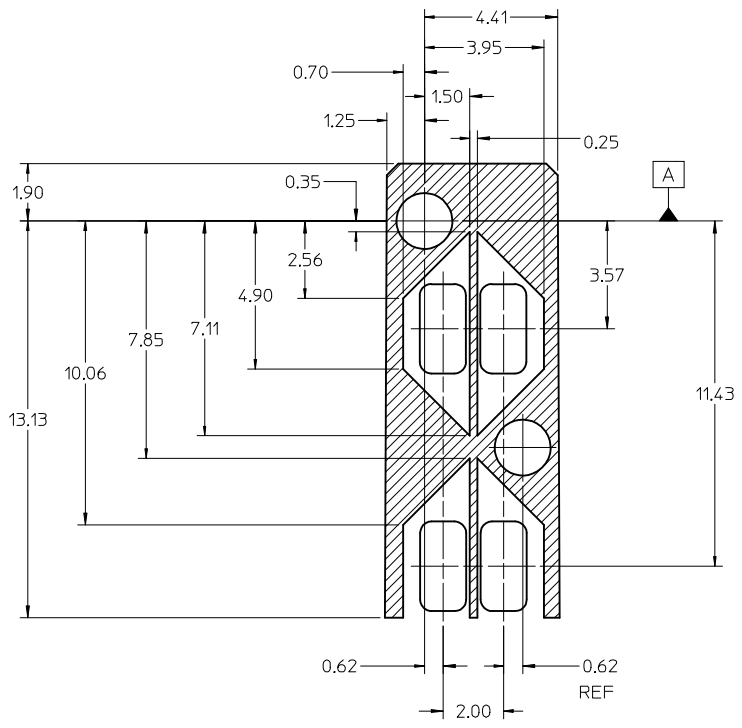

KEEPOUT ZONE DETAIL - LIGHTPIPE LOCATION AND OTHER ZONES
SCALE 8:1

THE HATCHED AREA IN THIS VIEW INDICATES ZONES THAT ARE OCCUPIED BY THE PLASTIC HOUSING THAT SEATS AGAINST THE PCB AND BY THE VERTICAL METAL CAGE WALL THAT STOPS JUST SHORT OF THE PCB

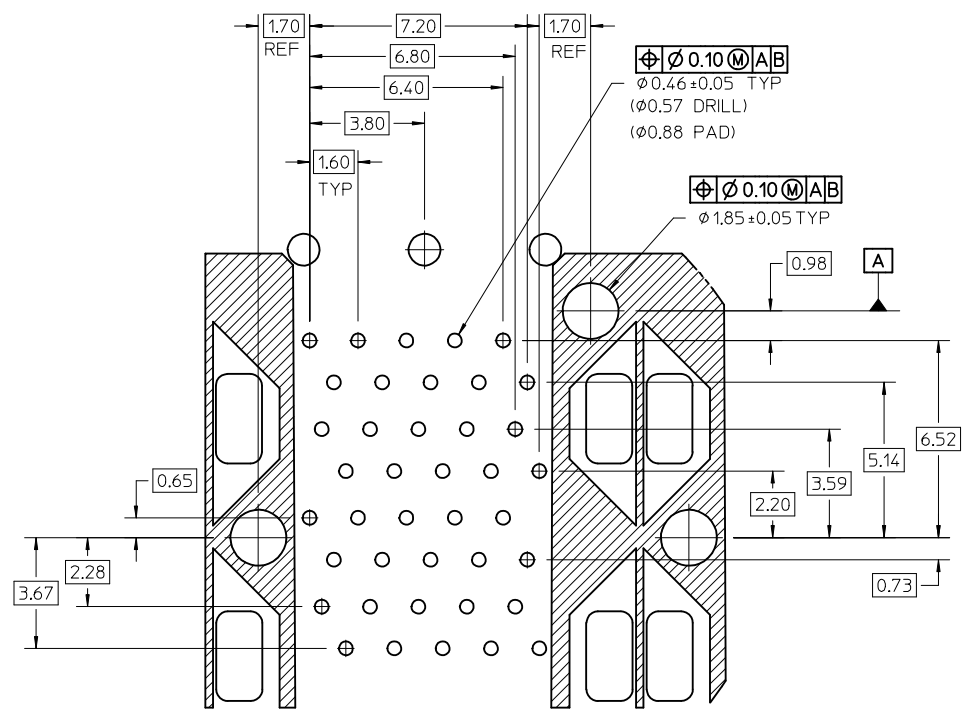

DETAIL B
SCALE 8:1

SEE SHEET 1 EC NO: UCP2016-3489 DRWNS:VANG01 2016/03/07 CHKD:BBARKER 2016/03/07 APPR:SMILLER 2016/03/25	QUALITY SYMBOLS ▽=0 ▽=0 ▽=0	GENERAL TOLERANCES (UNLESS SPECIFIED)		DIMENSION STYLE MM ONLY		SCALE 8:1	DESIGN UNITS METRIC	THIRD ANGLE PROJECTION		
		4 PLACES ± --- ± ---	mm INCH	DRAWN BY TIBARRA	DATE 2012/08/09	TITLE STACKED SFP+ 2X4 ASS'Y W/ METAL EMI GASKET AND LIGHTPIPES, ENHANCED EMI				SHEET NO. 4 OF 5
		3 PLACES ± --- ± ---	± 0.13 ± ---	CHECKED BY BBARKER	DATE 2012/08/15					
		2 PLACES ± 0.25 ± ---	± ± ---	APPROVED BY SMILLER	DATE 2012/08/28	DOCUMENT NO. SD-76046-0003				
1 PLACE ± 0.25 ± ---	± ± ---	MATERIAL NO. SEE TABLE								
0 PLACE ± ± ---	ANGULAR ± 5 °	DRAFT WHERE APPLICABLE MUST REMAIN WITHIN DIMENSIONS		SIZE C						

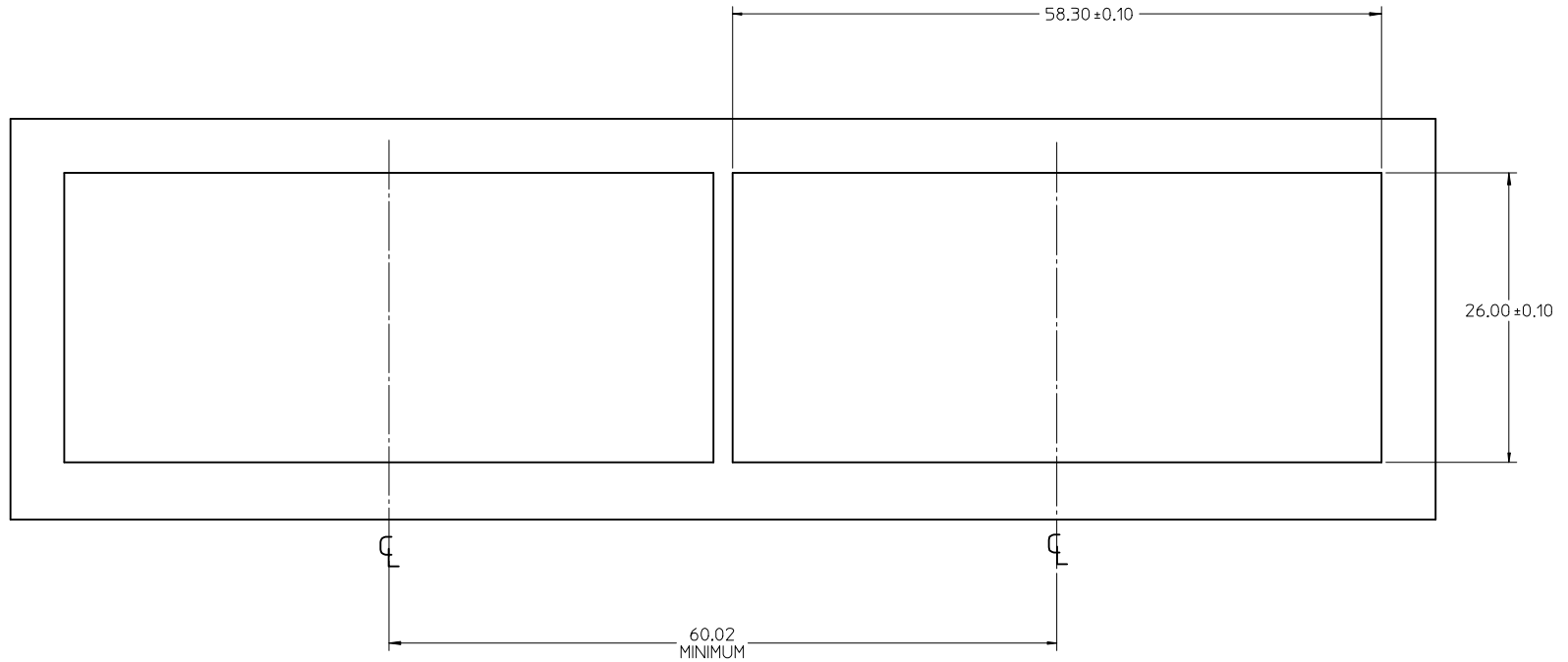

BEZEL CUTOUT CENTER SPACING DETAIL
BEZEL THICKNESS 0.8-2.6

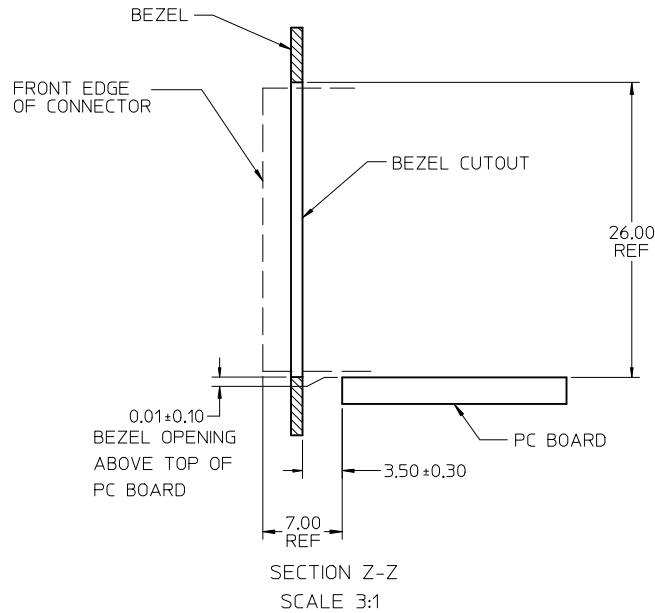

SEE SHEET 1 EC NO: UCP2016-3489 2016/03/07 IDRW:SVANG01 2016/03/07 CHKD:BBARKER 2016/03/07 APPR:SMILLER 2016/03/25	QUALITY SYMBOLS ∇=0 ∇=0 ∇=0	GENERAL TOLERANCES (UNLESS SPECIFIED)		DIMENSION STYLE MM ONLY		SCALE 3:1	DESIGN UNITS METRIC	THIRD ANGLE PROJECTION		
		4 PLACES ± --- ± ---	mm	INCH	DRAWN BY TIBARRA	DATE 2012/08/09	TITLE STACKED SFP+ 2X4 ASS'Y W/ METAL EMI GASKET AND LIGHTPIPES, ENHANCED EMI molex			
		3 PLACES ± --- ± ---			CHECKED BY BBARKER	DATE 2012/08/15				
		2 PLACES ± 0.13 ± ---			APPROVED BY SMILLER	DATE 2012/08/28	DOCUMENT NO. SD-76046-0003		SHEET NO. 5 OF 5	
1 PLACE ± 0.25 ± ---			ANGULAR ± 5 °		DRAFT WHERE APPLICABLE MUST REMAIN WITHIN DIMENSIONS		THIS DRAWING CONTAINS INFORMATION THAT IS PROPRIETARY TO MOLEX INCORPORATED AND SHOULD NOT BE USED WITHOUT WRITTEN PERMISSION			
0 PLACE ± ±			SIZE C							

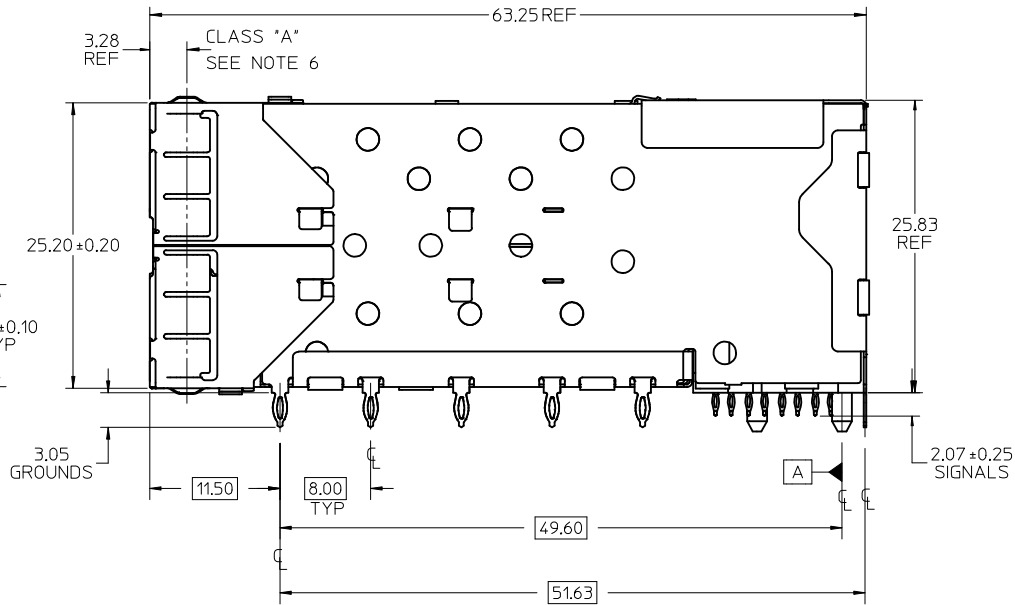
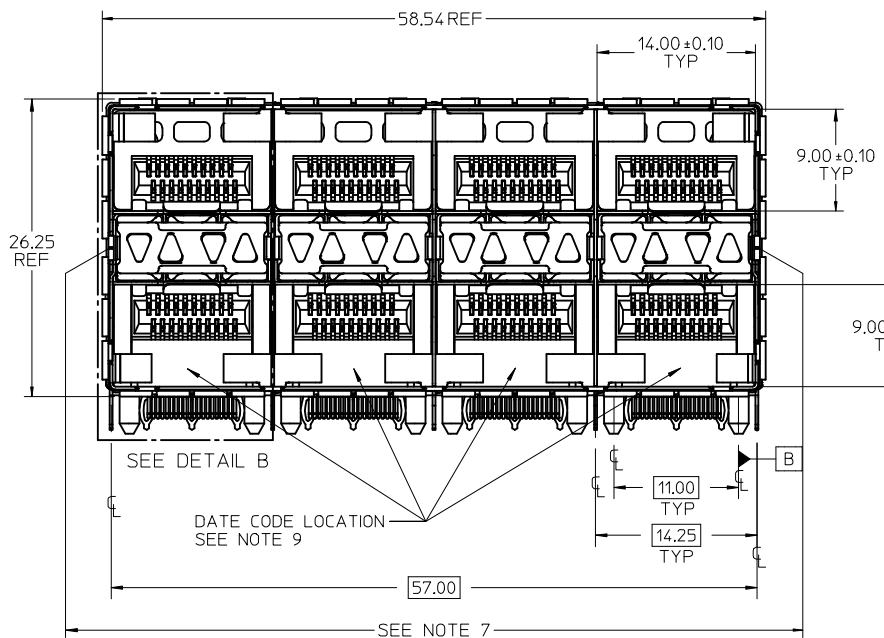

- NOTES**
- MATERIAL:**
 CAGE: NICKEL SILVER, THICKNESS: 0.25mm
 CONNECTOR HOUSING: GLASS FILLED LIQUID CRYSTAL POLYMER (LCP), UL 94V-0, COLOR: BLACK
 OVERMOLD TERMINAL HOUSING: GLASS FILLED LIQUID CRYSTAL POLYMER (LCP), UL 94V-0, COLOR: BLACK
 TERMINALS: TIN BRASS
 EMI GASKET: PHOS-BRONZE
 LIGHTPIPE HOUSING: ZINC
 LIGHTPIPES: POLYCARBONATE, COLOR: CLEAR
 - FINISHES:**
 TERMINALS: CONTACT AREA: 0.76 MICROMETERS MINIMUM HARD GOLD OVER 1.27 MICROMETERS MINIMUM NICKEL.
 COMPLIANT TAIL - MATTE TIN/LEAD OPTION: 0.76 TO 1.52 MICROMETERS 90/10 MATTE TIN-LEAD OVER 0.76 MICROMETERS MINIMUM NICKEL.
 COMPLIANT TAIL - MATTE TIN OPTION: 0.76 TO 1.52 MICROMETERS MATTE TIN OVER 0.76 MICROMETERS MINIMUM NICKEL.
 LIGHTPIPE HOUSING: 80 MICROMETERS MINIMUM NICKEL OVER COPPER
 EMI GASKET: 2.54 MICROMETERS MINIMUM NICKEL OVERALL.
 - REFER TO PS-75310-001 PRODUCT SPEC FOR ALL ELECTRICAL, MECHANICAL, AND ENVIRONMENTAL SPECIFICATIONS.
 - LIGHTPIPE PAD LAYOUT IS FOR 0805 LOW-PROFILE LED PACKAGE, FOR OTHER RECOMMENDED LAYOUTS REFER TO MOLEX'S REPORT TS-75310-001.
 - REFER TO PK-75450-001 FOR ALL PACKAGING SPECIFICATIONS.
 - THE SURFACES CONFORM TO THE MOLEX COSMETIC SPEC PS-45499-002. ALL EXTERIOR SURFACES TO BE CLASS 'B' SURFACE EXCEPT THE UNDERSIDE (CLASS 'C') OF THE CAGE (SIDE TOWARD THE PCB) AND AS OTHERWISE NOTED.
 - THE OVERALL CAGE WIDTH AT THE VERTICAL CENTER OF THE FRONT EDGE WILL FALL WITHIN THIS DIMENSION: 57.80±0.30 MM, THIS PORTION OF THE CAGE WILL FLEX INWARD AS THE CAGE IS BEING INSERTED INTO THE BEZEL OPENING.
 - REFER TO AS-76090-001 FOR HIGH SPEED ROUTING RECOMMENDATIONS.
 - DATE CODE LOCATION IS SHOWN ABOVE.
 DATE CODE FORMAT: DDDY MX A1
 DDD = DAY OF THE YEAR
 Y = YEAR
 MX = MOLEX
 A = ALPHA CHARACTER - INDICATES MANUFACTURING LINE
 1 = NUMERIC CHARACTER - INDICATES PRODUCTION SHIFT

PART NUMBER	DESCRIPTION	VIEW	COMPLIANT TAIL PLATING
760460001	4 LIGHT PORTS	SEE PG 2	MATTE TIN / LEAD
760460002	INNER 2 PORTS	SEE PG 2	MATTE TIN / LEAD
760460003	OUTER 2 PORTS	SEE PG 2	MATTE TIN / LEAD
760465001	4 LIGHT PORTS	SEE PG 2	MATTE TIN
760465002	INNER 2 PORTS	SEE PG 2	MATTE TIN
760465003	OUTER 2 PORTS	SEE PG 2	MATTE TIN

REV. NOTE 1 & 2 FOR EMI EC NO: UCP2016-3489 DRW:VANG01 2016/03/07 CHKD:BBARKER 2016/03/07 APPR:SMILLER 2016/03/25	QUALITY SYMBOLS ▽=0 ▽=0 ▽=0	GENERAL TOLERANCES (UNLESS SPECIFIED)		DIMENSION STYLE MM ONLY		SCALE 3:1	DESIGN UNITS METRIC	THIRD ANGLE PROJECTION	
		4 PLACES ± --- ± ---	3 PLACES ± --- ± ---	DRAWN BY MSANDBERG	DATE 1-26-2006	TITLE STACKED SFP+ 2X4 ASS'Y WITH METAL EMI GASKET AND LIGHTPIPES			
		2 PLACES ± 0.13 ± ---	1 PLACE ± 0.25 ± ---	CHECKED BY JLONG	DATE 1-26-2006	MATERIAL NO. SEE TABLE			
		0 PLACE ± ±	APPROVED BY RNELSON	DATE 1-26-2006	DOCUMENT NO. SD-76046-001				
DRAFT WHERE APPLICABLE MUST REMAIN WITHIN DIMENSIONS		SIZE C		THIS DRAWING CONTAINS INFORMATION THAT IS PROPRIETARY TO MOLEX INCORPORATED AND SHOULD NOT BE USED WITHOUT WRITTEN PERMISSION					

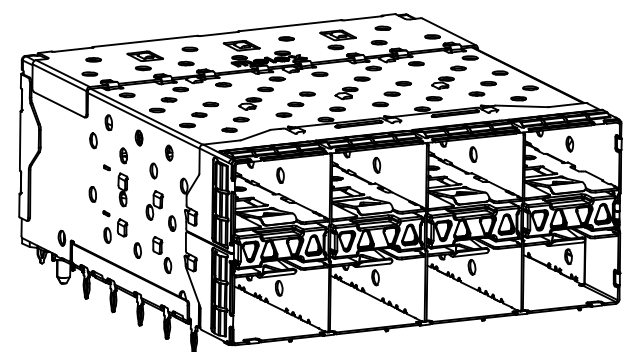

760460001 AND 760465001
WITH INNER AND OUTER LIGHTPIPES

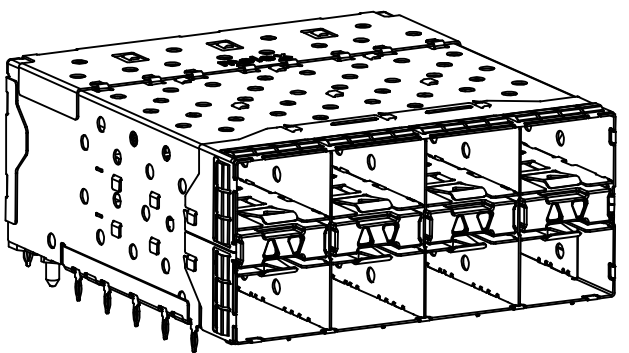

760460002 AND 760465002
WITH INNER LIGHTPIPES

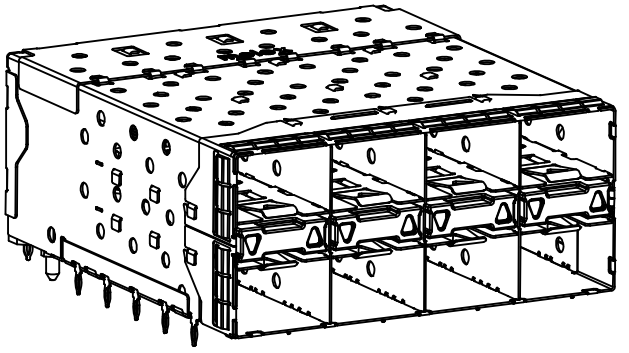

760460003 AND 760465003
WITH OUTER LIGHTPIPES

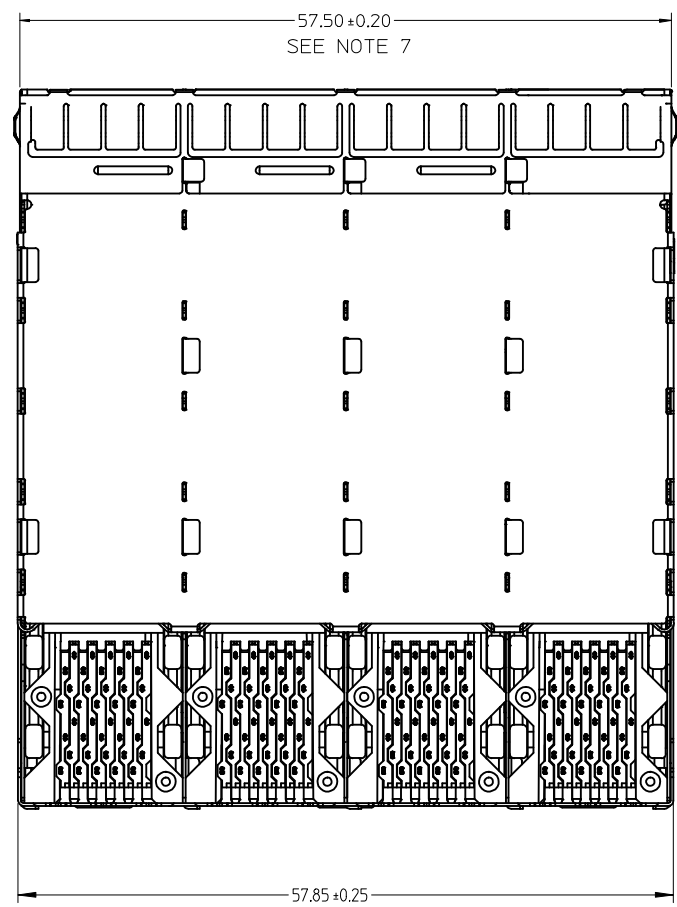

SEE SHEET 1 EC NO: UCP2016-3489 T DRWNS:VANG01 2016/03/07 CHKD:BBARKER 2016/03/07 APPR:SMILLER 2016/03/25	QUALITY SYMBOLS = 0 = 0 = 0	GENERAL TOLERANCES (UNLESS SPECIFIED) <table border="1"> <thead> <tr> <th></th> <th>mm</th> <th>INCH</th> </tr> </thead> <tbody> <tr> <td>4 PLACES</td> <td>± ---</td> <td>± ---</td> </tr> <tr> <td>3 PLACES</td> <td>± ---</td> <td>± ---</td> </tr> <tr> <td>2 PLACES</td> <td>± 0.13</td> <td>± ---</td> </tr> <tr> <td>1 PLACE</td> <td>± 0.25</td> <td>± ---</td> </tr> <tr> <td>0 PLACE</td> <td>±</td> <td>±</td> </tr> </tbody> </table>		mm	INCH	4 PLACES	± ---	± ---	3 PLACES	± ---	± ---	2 PLACES	± 0.13	± ---	1 PLACE	± 0.25	± ---	0 PLACE	±	±	DIMENSION STYLE MM ONLY DRAWN BY DATE MSANDBERG 1-26-2006 CHECKED BY DATE JLONG 1-26-2006 APPROVED BY DATE RNELSON 1-26-2006	SCALE 3:1 DESIGN UNITS METRIC THIRD ANGLE PROJECTION	TITLE STACKED SFP+ 2X4 ASS'Y WITH METAL EMI GASKET AND LIGHTPIPES molex
		mm	INCH																				
	4 PLACES	± ---	± ---																				
	3 PLACES	± ---	± ---																				
2 PLACES	± 0.13	± ---																					
1 PLACE	± 0.25	± ---																					
0 PLACE	±	±																					
MATERIAL NO. SEE TABLE	DOCUMENT NO. SD-76046-001	SHEET NO. 2 OF 5																					
DRAFT WHERE APPLICABLE MUST REMAIN WITHIN DIMENSIONS	SIZE 	THIS DRAWING CONTAINS INFORMATION THAT IS PROPRIETARY TO MOLEX INCORPORATED AND SHOULD NOT BE USED WITHOUT WRITTEN PERMISSION																					

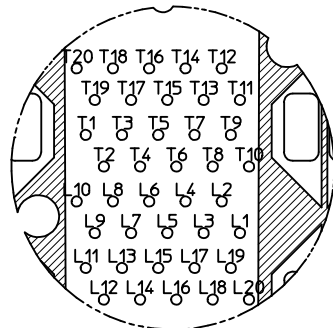

CIRCUIT NUMBERING
COMPONENT SIDE OF BOARD
SCALE 6:1

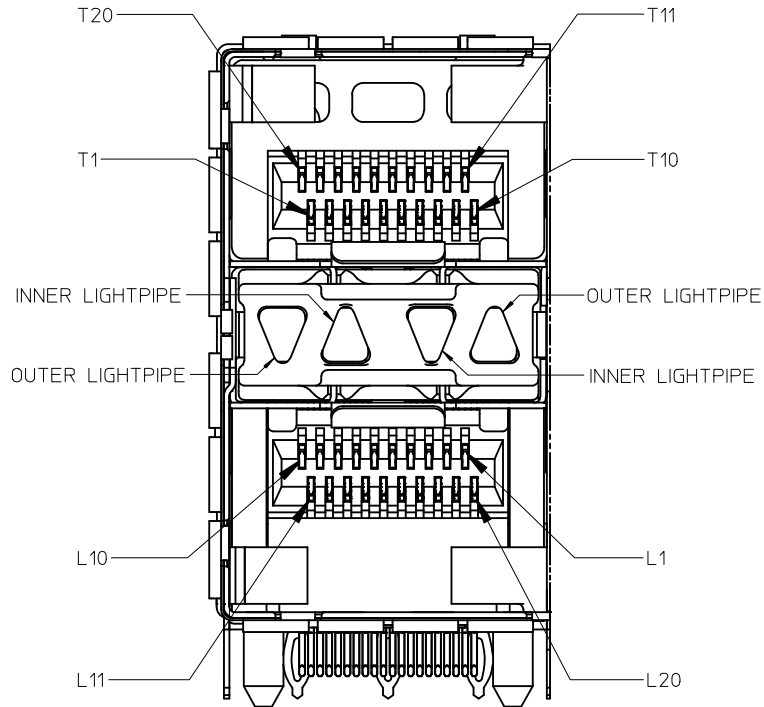

DETAIL B
SCALE 6:1
CIRCUIT NUMBERING
AND LIGHTPIPE
IDENTIFICATION

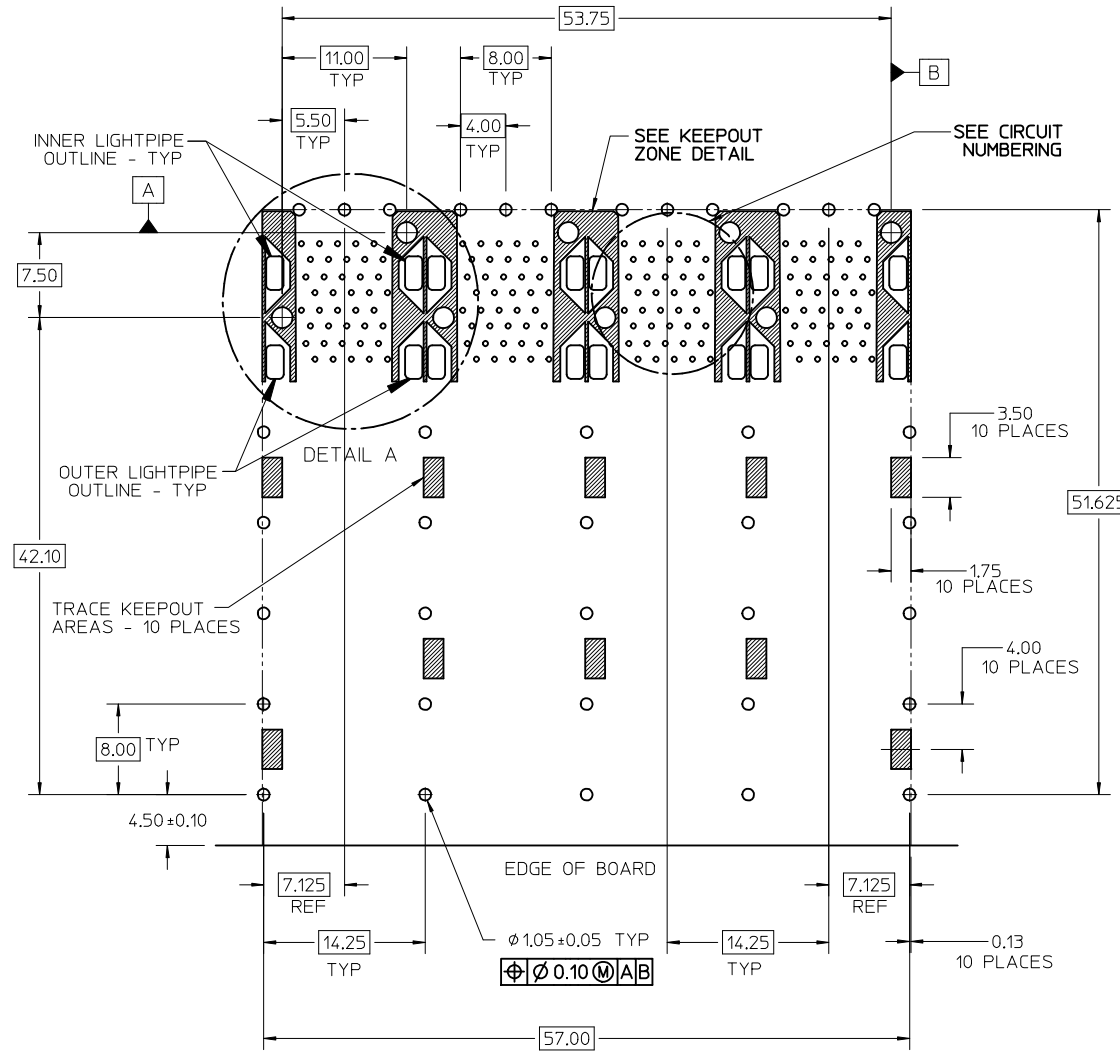

RECOMMENDED PCB LAYOUT - COMPONENT SIDE
RECOMMENDED PCB THICKNESS - 2.36 MM (.093 INCH)

THE ENTIRE AREA OF THE CONNECTOR FOOTPRINT
TO BE CONSIDERED THE KEEP OUT AREA FOR COMPONENTS
(OTHER THAN THE LIGHTPIPE LED'S)
THIS AREA IS INDICATED BY THE DASHED LINE

SEE SHEET 1 EC NO: UCP2016-3489 DRAWN BY: MSANDBERG CHECKED BY: JLONG APPROVED BY: RNELSON MATERIAL NO. DRAWN DATE: 2016/03/07 CHECKED DATE: 2016/03/07 APPROVED DATE: 2016/03/25	QUALITY SYMBOLS	GENERAL TOLERANCES (UNLESS SPECIFIED)	DIMENSION STYLE MM ONLY	SCALE 3:1	DESIGN UNITS METRIC	THIRD ANGLE PROJECTION
	▽=0 ▽=0 ▽=0	mm INCH 4 PLACES ± --- ± --- 3 PLACES ± --- ± --- 2 PLACES ± 0.13 ± --- 1 PLACE ± 0.25 ± --- 0 PLACE ± ±	DRAWN BY DATE MSANDBERG 1-26-2006 CHECKED BY DATE JLONG 1-26-2006 APPROVED BY DATE RNELSON 1-26-2006	TITLE STACKED SFP+ 2X4 ASS'Y WITH METAL EMI GASKET AND LIGHTPIPES	DOCUMENT NO. SD-76046-001	SHEET NO. 3 OF 5
REV	DESCRIPTION	ANGULAR ± 5 °	SEE TABLE	THIS DRAWING CONTAINS INFORMATION THAT IS PROPRIETARY TO MOLEX INCORPORATED AND SHOULD NOT BE USED WITHOUT WRITTEN PERMISSION		
DRAFT WHERE APPLICABLE MUST REMAIN WITHIN DIMENSIONS						

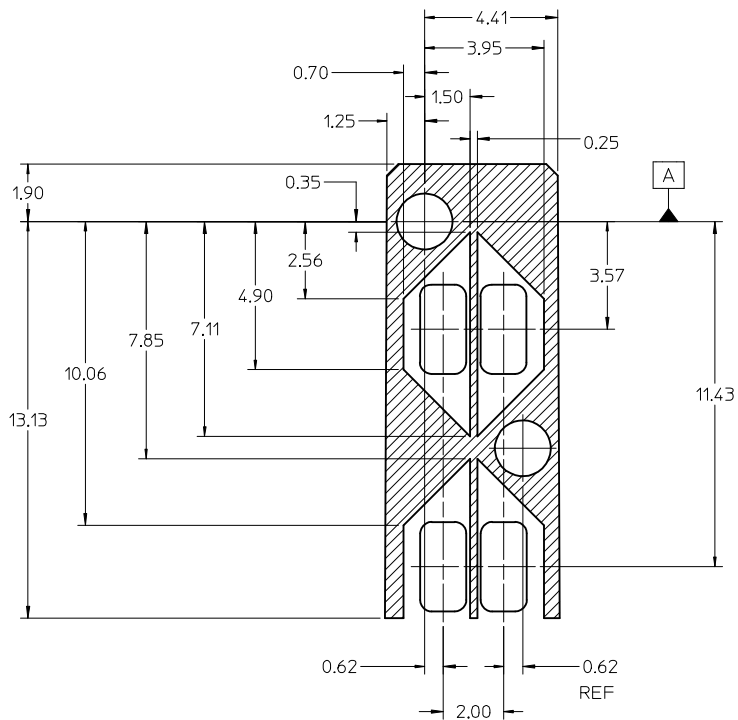

KEEPOUT ZONE DETAIL - LIGHTPIPE LOCATION AND OTHER ZONES
SCALE 8:1

THE HATCHED AREA IN THIS VIEW INDICATES ZONES THAT ARE OCCUPIED BY THE PLASTIC HOUSING THAT SEATS AGAINST THE PCB AND BY THE VERTICAL METAL CAGE WALL THAT STOPS JUST SHORT OF THE PCB

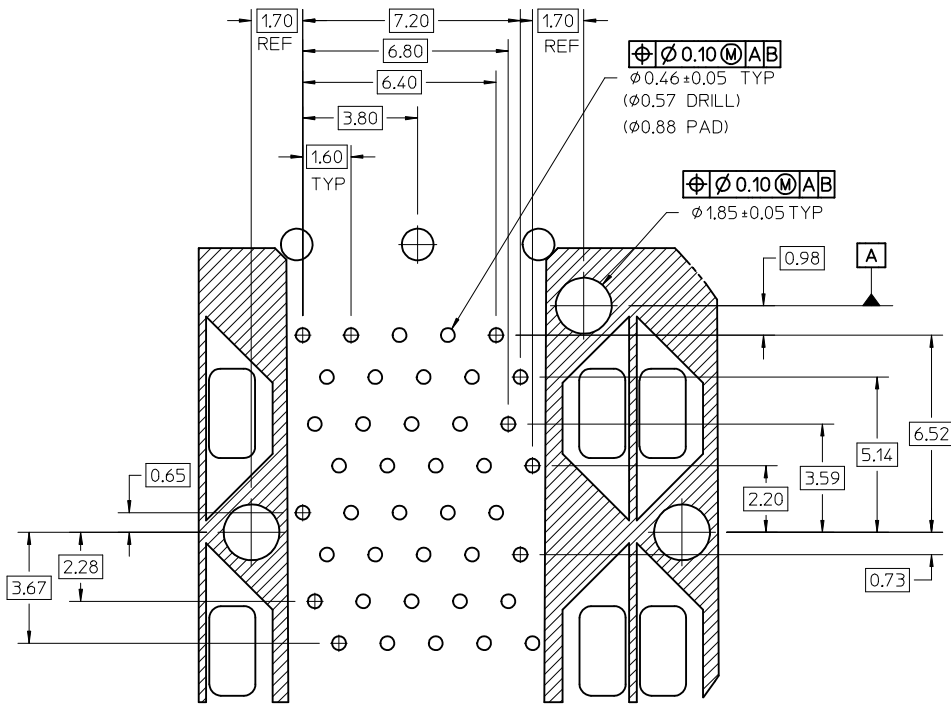

DETAIL A
SCALE 8:1

SEE SHEET 1 EC NO: UCP2016-3489 DRAWN BY: 2016/03/07 MSANDBERG CHECKED BY: 2016/03/07 JLONG APPROVED BY: 2016/03/25 RNELSON	QUALITY SYMBOLS ▽=0 ▽=0 ▽=0	GENERAL TOLERANCES (UNLESS SPECIFIED)		DIMENSION STYLE MM ONLY	SCALE 8:1	DESIGN UNITS METRIC	THIRD ANGLE PROJECTION	
		4 PLACES ± --- ± ---	3 PLACES ± --- ± ---	2 PLACES ± 0.13 ± ---	1 PLACES ± 0.25 ± ---	0 PLACE ± ±	ANGULAR ± 5 °	DRAFT WHERE APPLICABLE MUST REMAIN WITHIN DIMENSIONS
				MATERIAL NO.	DOCUMENT NO.	TITLE STACKED SFP+ 2X4 ASS'Y WITH METAL EMI GASKET AND LIGHTPIPES molex		
				SEE TABLE	SD-76046-001		SHEET NO. 4 OF 5	

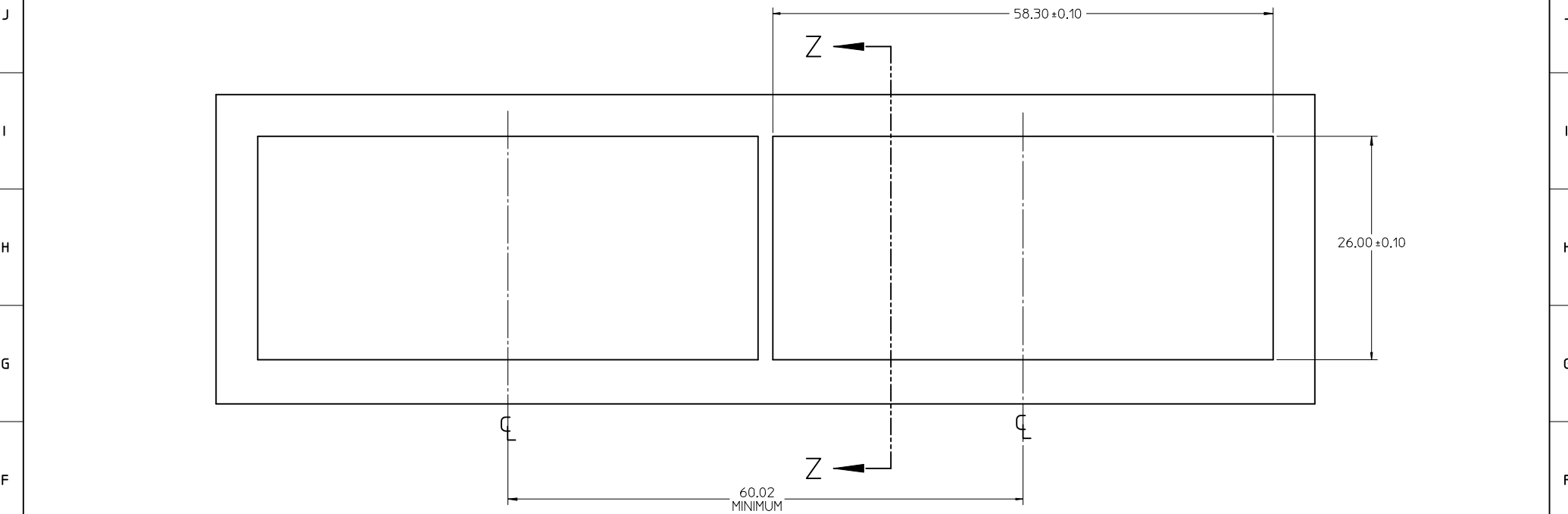

BEZEL CUTOUT CENTER SPACING DETAIL
BEZEL THICKNESS 0.8-2.6

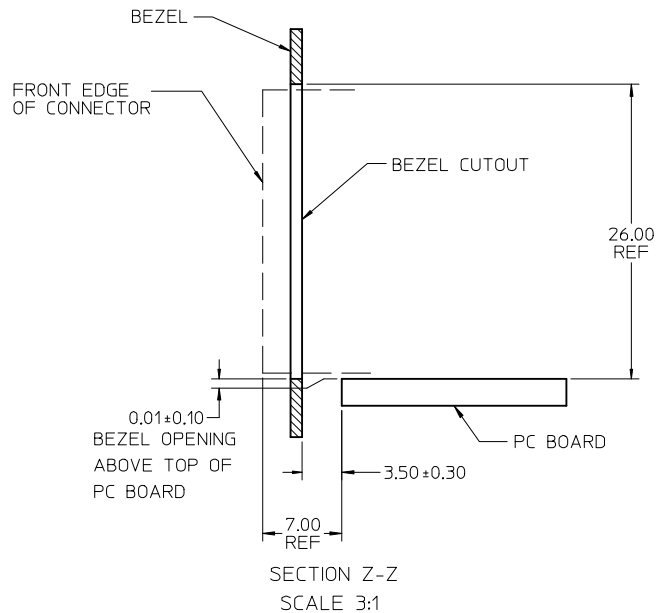

SEE SHEET 1 EC NO: UCP2016-3489 DRAWN: SVANG01 2016/03/07 CHKD: BBARKER 2016/03/07 APPR: SMILLER 2016/03/25	QUALITY SYMBOLS ▽=0 ▽=0 ▽=0	GENERAL TOLERANCES (UNLESS SPECIFIED)		DIMENSION STYLE MM ONLY		SCALE 3:1	DESIGN UNITS METRIC	THIRD ANGLE PROJECTION		
			mm	INCH	DRAWN BY MSANDBERG	DATE 1-26-2006	TITLE STACKED SFP+ 2X4 ASS'Y WITH METAL EMI GASKET AND LIGHTPIPES			
		4 PLACES ± ---	± ---	± ---	CHECKED BY JLONG	DATE 1-26-2006				
		3 PLACES ± ---	± ---	± ---	APPROVED BY RNELSON	DATE 1-26-2006	DOCUMENT NO. SD-76046-001			
2 PLACES ± 0.13	± ---	± ---	MATERIAL NO.		SHEET NO. 5 OF 5					
1 PLACE ± 0.25	± ---	± ---	ANGULAR ± 5 °		SEE TABLE					
0 PLACE ±	±	±	DRAFT WHERE APPLICABLE MUST REMAIN WITHIN DIMENSIONS		THIS DRAWING CONTAINS INFORMATION THAT IS PROPRIETARY TO MOLEX INCORPORATED AND SHOULD NOT BE USED WITHOUT WRITTEN PERMISSION					