

PART NUMBER	REVISION	DESCRIPTION	FEED TYPE
2151332-2	AB	FINE CRIMP HEIGHT ADJUST	PNEUMATIC
3-2151332-2	AB	FINE CRIMP HEIGHT ADJUST	DOUBLE ACTING PNEUMATIC WITH SENSORS
7-2151332-2	AB	PNEUMATIC AND CRIMP TOOLING KIT	PNEUMATIC
7-2151332-7	Y	CRIMP TOOLING KIT	-

ATLANTIC VERSION TERMINATOR INTERFACE ADAPTER

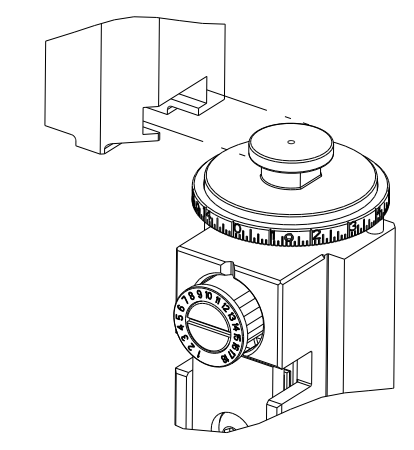

APPLICATOR DATA

CRIMP	SIZE	TYPE
WIRE	0.89 mm [.035]	F
INSUL	1.07 mm [.042]	O

APPLICATOR INSTRUCTIONS
408-35042

TERMINAL DATA: TE TERMINAL TE CRIMP SPECIFICATION

TERMINAL NAME: NANO MQS TERMINAL

WIRE STRIP LENGTH	INSULATION DIAMETER RANGE
3.25-3.55 mm [.128-.140 IN]	Ø0.85-1.10 mm [.033-.043 IN]

TERMINAL APPLICATION SPECIFICATION (A)114-18858 (B)114-137526

TERMINALS APPLIED

TE TERMINAL	TE TERMINAL	TE TERMINAL	TE TERMINAL
(A)1-1703930-1	(A)1-1703930-2	(B)2834464-5	

WIRE SIZE	CRIMP HEIGHT mm [INCH]	CRIMP HEIGHT REFERENCE SETTING
0.17mm2	0.63+/-0.02 [.0248+/- .0008]	6.5
0.13mm2	0.59+/-0.02 [.0232+/- .0008]	7.0

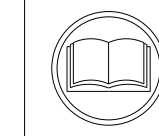

- 1. RECOMMENDED SPARE PARTS
- 2. REFER TO SUPPLIED INSTRUCTION SHEET FOR CLEANING, LUBRICATION AND STORAGE OF APPLICATOR.
- 3. APPLY PART NUMBER 2-23419-6 LOCTITE TO THREADS OF ITEM 242.
- 4. CRIMP HEIGHT REFERENCE SETTING WAS THE SETTING USED WHEN THE APPLICATOR WAS QUALIFIED AT THE FACTORY. ADJUSTMENT MAY BE NECESSARY WHEN RUNNING APPLICATOR IN THE FIELD.
- 5. THIS APPLICATOR IS EQUIPPED WITH THE DOUBLE ACTING FEED WITH SENSORS AND IS APPLICATION SPECIFIC AND DOES NOT REQUIRE ITEMS 49 & 248.
- 6. TERMINAL LUBRICANT IS RECOMMENDED.
- 7. UNLESS SPECIFIED OTHERWISE TORQUE VALUES SHALL BE USED PER DOCUMENT, 101-35000.

***WARNING**
 ON INSTALLATION, SET WIRE DISC TO CRIMP HEIGHT REFERENCE SETTING FOR LARGEST WIRE SIZE. CRIMP HEIGHT REFERENCE SETTINGS GREATER THAN THE VALUE SHOWN MAY CAUSE DAMAGE TO THE CRIMP TOOLING. REFER TO THE INSTRUCTION SHEET FOR PROPER SETUP AND ADJUSTMENTS

ATLANTIC VERSION
 Shown on sheets 1 of 4 & 2 of 4
 (Pacific version shown on sheets 3 of 4 & 4 of 4)

LOC	DIST	REVISIONS					
		P	LTN	DESCRIPTION	DATE	DWN	APVD
A	66	Z		ECR-21-001302	01FEB2021	JWC	GB
		Z1		ECR-21-003710	26MAR2021	FJ	YY
		AA		ECR-21-120047	08NOV2021	FZ	RK
		AB		ECR-22-147424	26JUL2022	TB	RK

-	1	1	1	1803945-4	TONKER	300
-	1	1	1	22278-9	SPRING, COMPRESSION	299
-	2	2	2	4-18032-3	SCR, SET, FLT PNT, M3 X 6.0	298
-	1	1	1	1803944-1	SPACER, TONKER	297
-	-	1	-	2844950-1	AIR FEED MODULE	290
-	1	1	1	2119791-9	DEPRESSOR, WIRE	286
-	1	1	1	1-22281-8	SPRING, COMPRESSION	262
-	1	1	1	2168083-6	SCR, SKT HD CAP, RoHS, M5 X 6.5	261
-	1	-	1	2119641-1	FEED CAM, AIR FEED	248
-	1	1	1	2119082-5	CAM, SNAIL, INSULATION ADJUSTMENT	244
-	1	1	1	2079764-1	WASHER, WAVE SPRING, CREST-TO-CREST	243
-	1	1	1	2119083-1	RETAINER, INSULATION DIAL	242
-	1	-	1	2844940-1	AIR FEED MODULE	238
-	REF	REF	REF	994970-2	COUNTER, MAGNETIC	164
-	1	1	1	2119955-1	ASSY, LUBRICATOR, SIDE FEED	113
-	1	1	1	2844908-1	SCREW, LOCKING	99
-	1	1	1	2844907-1	POST, LOCKING	98
-	1	1	1	1-690438-0	FRONT STRIP GUIDE	96
-	2	2	2	2168083-1	SCR, SKT HD CAP, RoHS, M3 X 8.0	95
-	1	1	1	455888-4	SPACER, CRIMPER	82
-	1	1	1	1803607-3	DOCUMENTATION PACKAGE	71
-	1	1	1	2119791-9	DEPRESSOR, WIRE	70
-	1	1	1	2119740-1	TAG, IDENTIFICATION	67
-	2	2	2	2168078-1	SCREW, DRIVE, RH, RoHS, 2 x .188	66
-	1	1	1	2-18032-5	SCR, SET, FLT PNT, M5 X 20.0	64
-	1	1	1	2-1722335-1	THREAD BOLT GEWINDEBOLZEN	61
-	1	1	1	2168083-2	SCR, SKT HD CAP, RoHS, M4 X 8.0	60
-	1	1	1	5-18022-5	SCR, HEX HD CAP, M4 X 6.0	59
-	1	1	1	1338685-1	PAWL, FEED	56
-	4	4	4	2168083-3	SCR, SKT HD CAP, RoHS, M4 X 12.0	54
-	2	2	2	2168083-8	SCR, SKT HD CAP, RoHS, M4 X 16	53
-	1	-	1	18023-9	SCR, SKT HD CAP M4 X 6.0	49
-	1	1	1	1803583-9	APPLICATOR BASIC ASSEMBLY, SF	46
-	1	1	1	1803515-1	RAM ASSEMBLY, SF ATLANTIC	44
-	1	1	1	1803602-1	SCR, BHSC, RoHS (M8 X 25)	41
-	1	1	1	1752356-3	SUPPORT, TERMINAL	34
-	2	2	2	2079383-5	SCR, BHSC, RoHS (M4 X 20)	33
-	2	2	2	2-2844962-4	SPACER, CYLINDRICAL, STRIP GUIDE	30
-	1	1	1	2844938-1	PLATE, STRIP GUIDE	29
-	2	2	2	22283-1	SPRING, COMPRESSION	27
-	1	1	1	356835-1	LEVER, DRAG RELEASE	26
-	1	1	1	1803142-1	DRAG, TERMINAL	25
-	1	1	1	1320928-2	STRIP GUIDE	24
-	1	1	1	980371-4	SCR, SKT HD SHLDR 5.0 DIA X 6.0	23
-	1	1	1	2168083-2	SCR, SKT HD CAP, RoHS, M4 X 8.0	21
-	2	2	2	1-18028-2	WASHER, FLAT, REG M4	20
-	1	1	1	2119533-1	STRIPPER, SIDE FEED	19
-	1	1	1	3-22280-3	SPRING, COMPRESSION	12
-	1	1	1	2-519000-1	SCR, SKT HD CAP M4 X 10.0	11
-	1	1	1	2119805-1	SHEAR HOLDER, FRONT	10
-	1	1	1	2-1803095-3	FLOATING SHEAR, FRONT	9
-	1	2	1	1633689-5	ANVIL, COMBINATION	8
-	1	1	1	2-240641-4	SPACER	7
-	1	1	1	1-2119757-8	DEPRESSOR, SHEAR	5
-	1	1	1	6-238011-0	BLOCK, CRIMPER SPACER	4
-	1	2	1	4-1803019-7	CRIMPER, INSULATION O	3
-	-	-	-	-	-	2
-	1	2	1	1803697-2	CRIMPER, WIRE PREMIUM, STEPPED	1

DIMENSIONS:	TOLERANCES UNLESS OTHERWISE SPECIFIED:	OWN	DATE	TE Connectivity	
mm	0 PLC ± 1 PLC ± 2 PLC ± 3 PLC ± 4 PLC ± ANGLES ±	C. CHEN	05MAY2011	Harrisburg, PA 17105-3608	
		S. XI	05MAY2011	NAME	
		J. CRUZ	05MAY2011	Ocean Side Feed Applicator	
MATERIAL:	FINISH:	APVD	PRODUCT SPEC	SIZE	CAGE CODE
			APPLICATION SPEC	A1	00779
		WEIGHT		DRAWING NO	RESTRICTED TO
				C=2151332	
				Customer Accessible Production Drawing	SCALE 1:2 SHEET 1 OF 4 REV AB

LOC	DIST	REVISIONS			
P	LTN	DESCRIPTION	DATE	DWN	APVD
A	66	SEE SHEET 1			

FEED TYPE PNEUMATIC

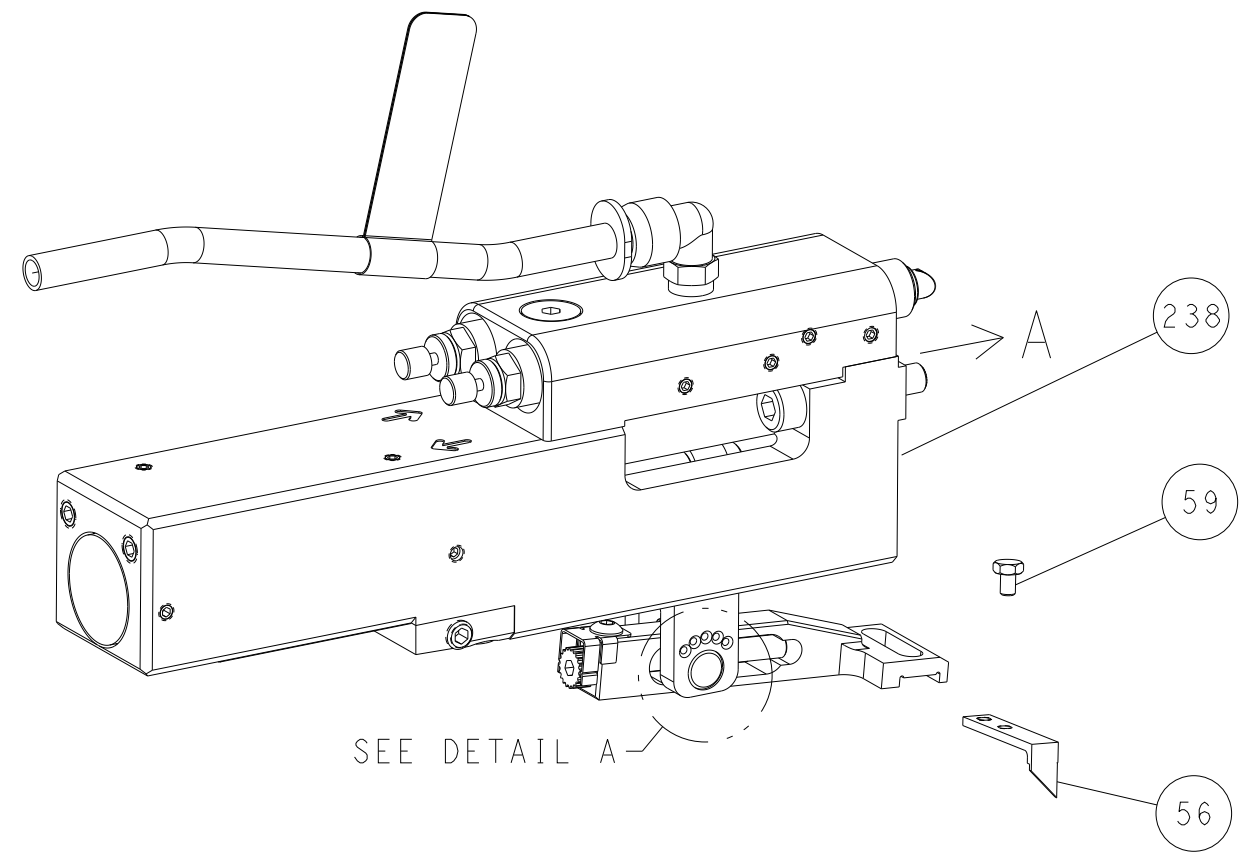

FEED SPRING SETTING POSITION (SHOWN FROM REAR SIDE)

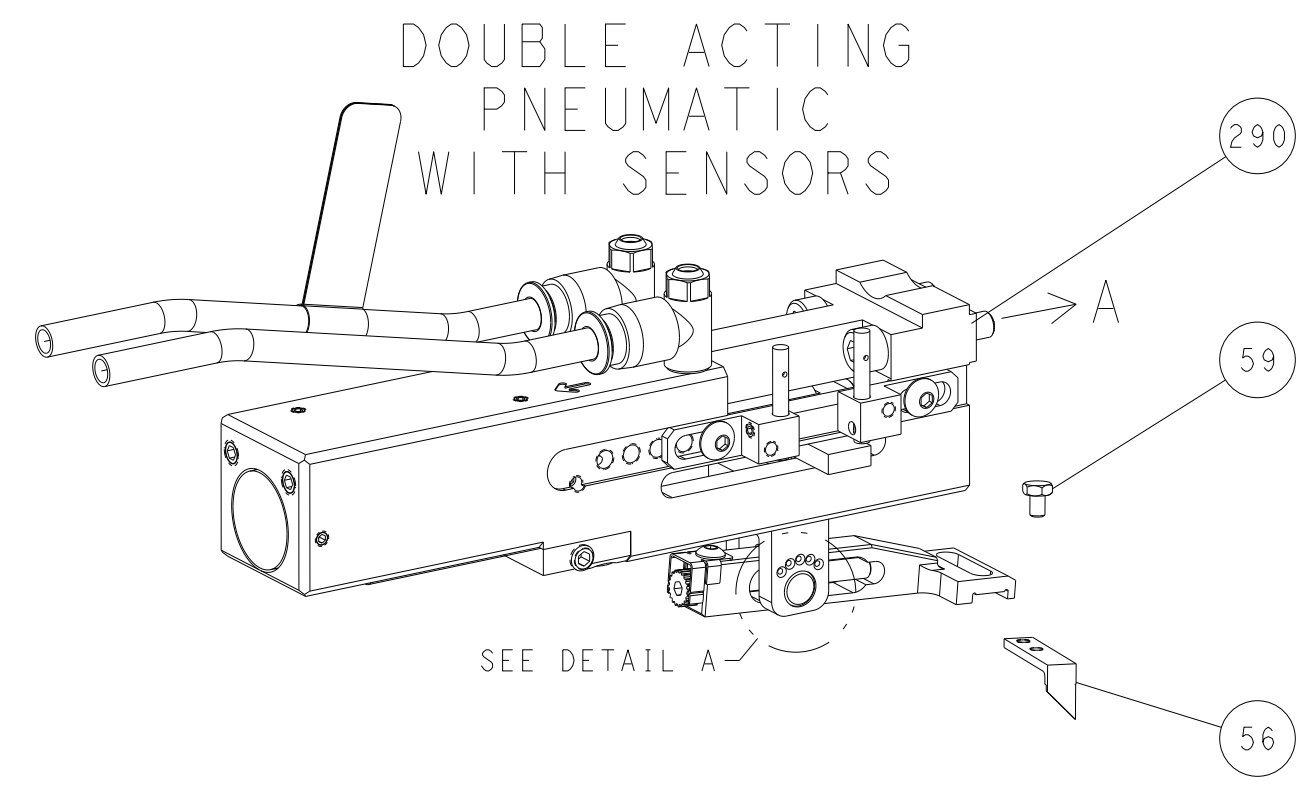
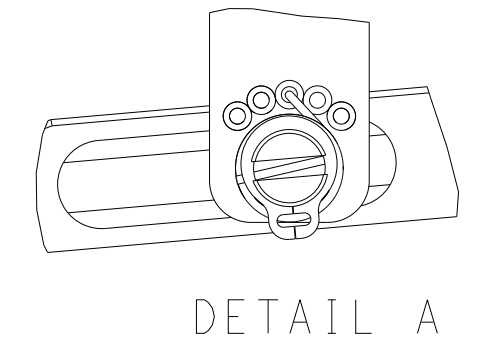

CAM POSITION

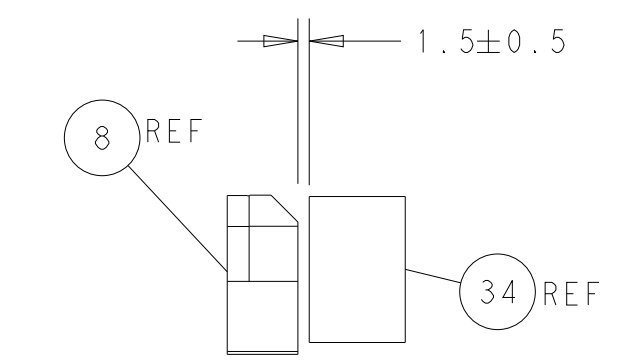
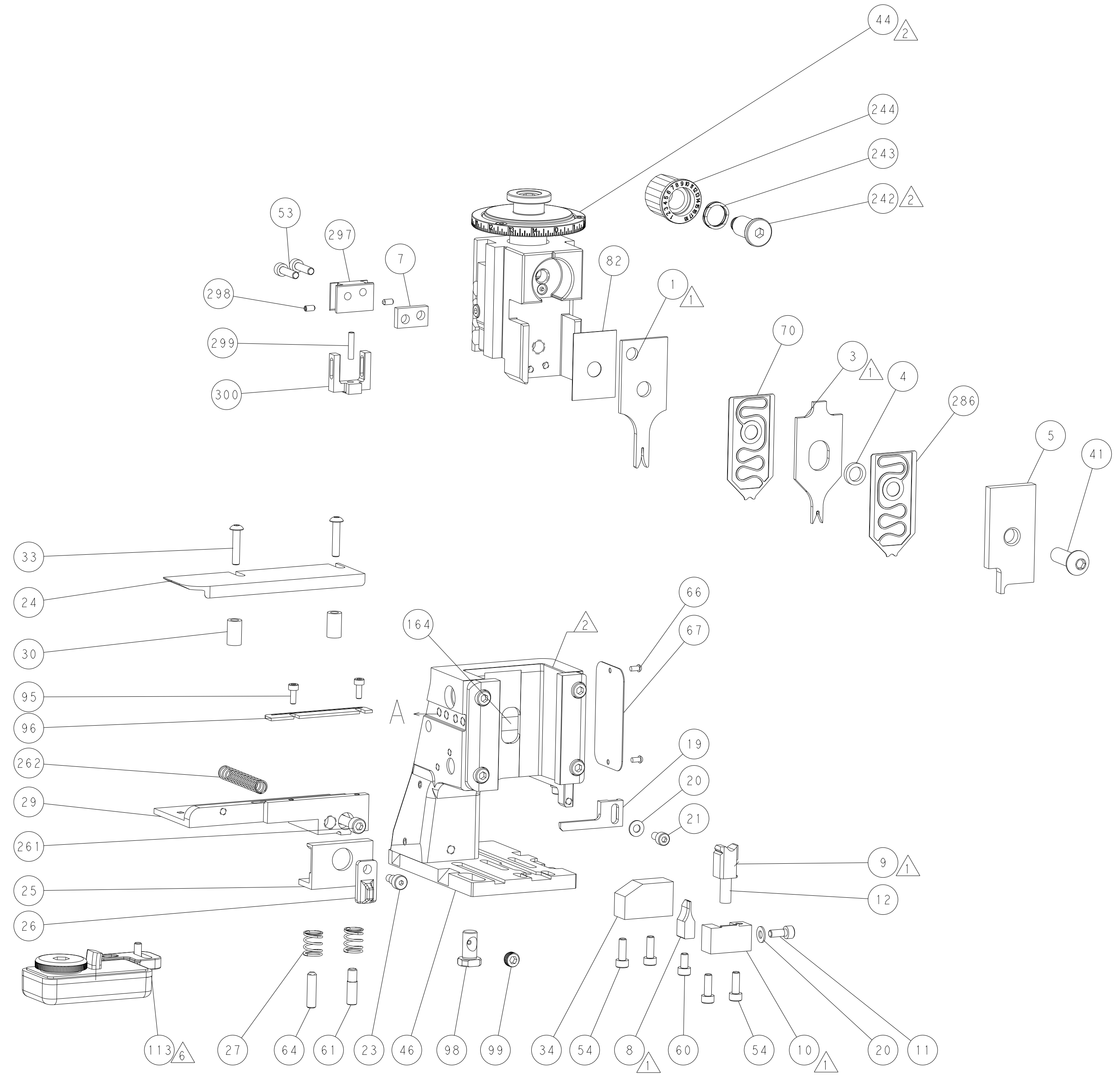
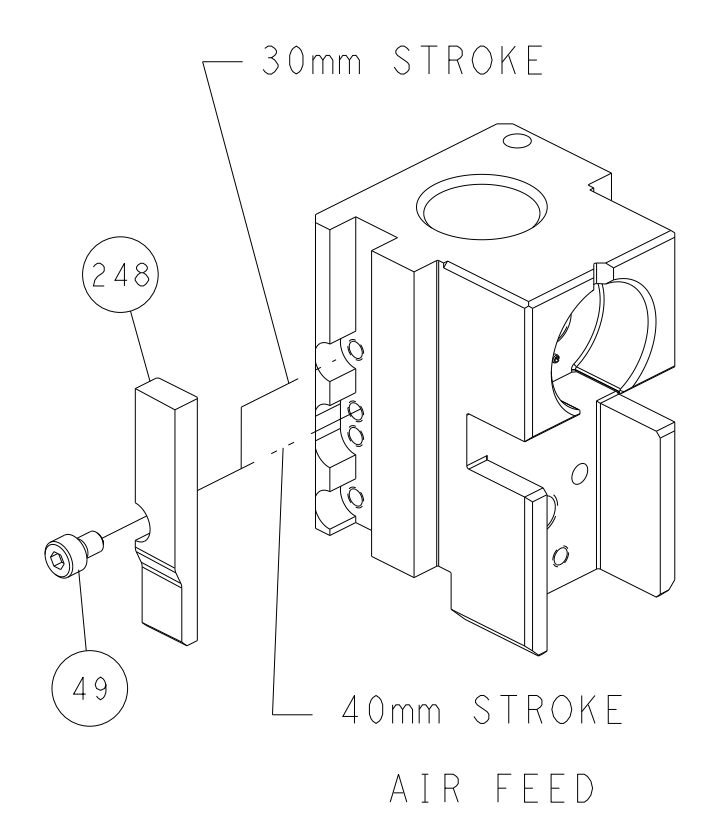

TERMINAL SUPPORT LOCATION

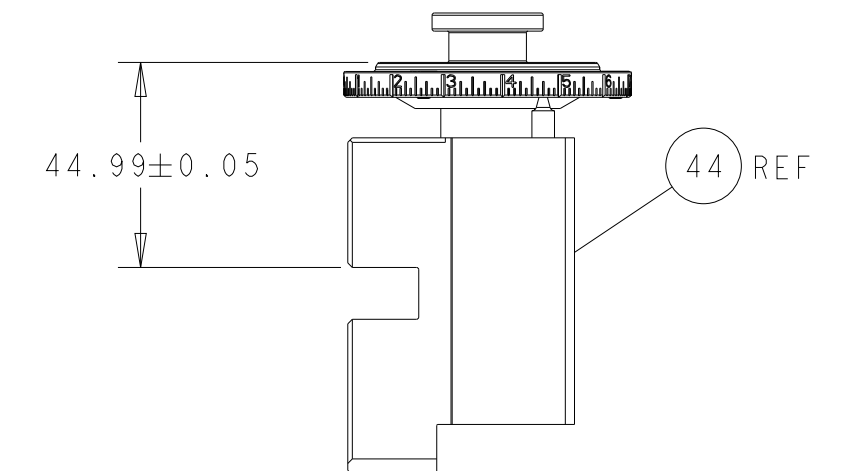

RAM SET-UP

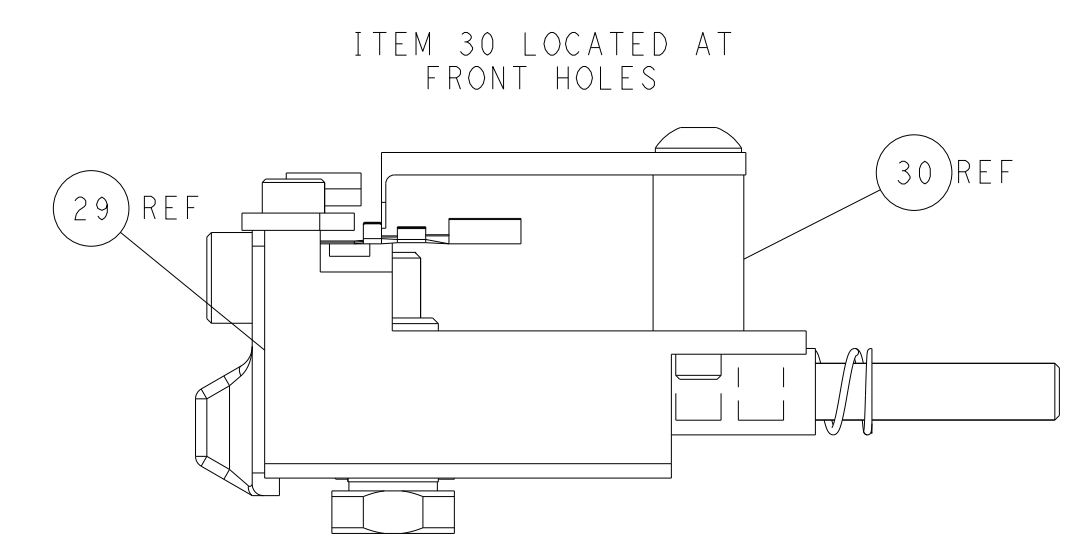

FEED TRACK POSITION GUIDE BY INSULATION BARREL

ATLANTIC VERSION
 Shown on sheets 1 of 4 & 2 of 4
 (Pacific version shown on sheets 3 of 4 & 4 of 4)

<small>THIS DRAWING IS A CONTROLLED DOCUMENT FOR TYCO ELECTRONICS CORPORATION. IT IS THE PROPERTY OF TYCO ELECTRONICS CORPORATION AND IS NOT TO BE REPRODUCED OR TRANSMITTED IN ANY FORM OR BY ANY MEANS, ELECTRONIC OR MECHANICAL, INCLUDING PHOTOCOPYING, RECORDING, OR BY ANY INFORMATION STORAGE AND RETRIEVAL SYSTEM, WITHOUT THE WRITTEN PERMISSION OF TYCO ELECTRONICS CORPORATION.</small>		DWN: C. CHEN 05MAY2011 CHK: S. XI 05MAY2011 APVD: J. CRUZ 05MAY2011	TE Connectivity Harrisburg, PA 17105-3608
DIMENSIONS: mm TOLERANCES UNLESS OTHERWISE SPECIFIED: 0 PLC ± 1 PLC ± 2 PLC ± 3 PLC ± 4 PLC ± ANGLES ± MATERIAL: - FINISH: -		NAME: Ocean Side Feed Applicator SIZE: A1 CAGE CODE: 00779 DRAWING NO: C-2151332 RESTRICTED TO: -	SCALE: 1:2 SHEET: 2 OF 4 REV: AB
CUSTOMER ACCESSIBLE PRODUCTION DRAWING		SHEETS 3 & 4 ARE NOT REQUIRED FOR ATLANTIC VERSION	

PART NUMBER	REVISION	DESCRIPTION	FEED TYPE
2-2151332-2	AB	FINE CRIMP HEIGHT ADJUST	PNEUMATIC
4-2151332-2	AB	FINE CRIMP HEIGHT ADJUST	DOUBLE ACTING PNEUMATIC WITH SENSORS
7-2151332-7	Y	CRIMP TOOLING KIT	-

PACIFIC VERSION TERMINATOR INTERFACE ADAPTER

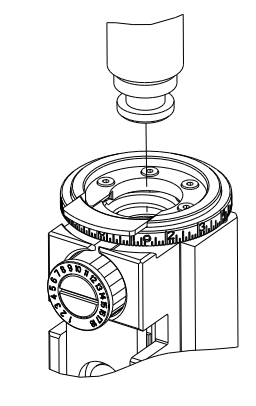

APPLICATOR DATA		
CRIMP	SIZE	TYPE
WIRE	0.89 mm [.035]	F
INSUL	1.07 mm [.042]	O
APPLICATOR INSTRUCTIONS 408-35042		

TERMINAL DATA: TE TERMINAL		TE CRIMP SPECIFICATION	
TERMINAL NAME: NANO MQS TERMINAL			
WIRE STRIP LENGTH		INSULATION DIAMETER RANGE	
3.25-3.55 mm [.128-.140 IN]		∅0.85-1.10 mm [.033-.043 IN]	
TERMINAL APPLICATION SPECIFICATION	(A)114-18858		
	(B)114-137526		
TERMINALS APPLIED			
TE TERMINAL	TE TERMINAL	TE TERMINAL	TE TERMINAL
(A)1-1703930-1	(A)1-1703930-2	(B)2834464-5	

WIRE SIZE	CRIMP HEIGHT mm [INCH]	CRIMP HEIGHT REFERENCE SETTING
0.17mm2	0.63+/-0.02 [.0248+/- .0008]	6.5
0.13mm2	0.59+/-0.02 [.0232+/- .0008]	7.0

- 1 RECOMMENDED SPARE PARTS
- 2 REFER TO SUPPLIED INSTRUCTION SHEET FOR CLEANING, LUBRICATION AND STORAGE OF APPLICATOR.
- 3 APPLY PART NUMBER 2-23419-6 LOCTITE TO THREADS OF ITEM 242.
- 4 CRIMP HEIGHT REFERENCE SETTING WAS THE SETTING USED WHEN THE APPLICATOR WAS QUALIFIED AT THE FACTORY. ADJUSTMENT MAY BE NECESSARY WHEN RUNNING APPLICATOR IN THE FIELD.
- 5 THIS APPLICATOR IS EQUIPPED WITH THE DOUBLE ACTING FEED WITH SENSORS AND IS APPLICATION SPECIFIC AND DOES NOT REQUIRE ITEMS 49 & 151.
- 6 TERMINAL LUBRICANT IS RECOMMENDED.
- 7. UNLESS SPECIFIED OTHERWISE TORQUE VALUES SHALL BE USED PER DOCUMENT, 101-35000.

***WARNING**
ON INSTALLATION, SET WIRE DISC TO CRIMP HEIGHT REFERENCE SETTING FOR LARGEST WIRE SIZE. CRIMP HEIGHT REFERENCE SETTINGS GREATER THAN THE VALUE SHOWN MAY CAUSE DAMAGE TO THE CRIMP TOOLING. REFER TO THE INSTRUCTION SHEET FOR PROPER SETUP AND ADJUSTMENTS

ENTRY LEVEL APPLICATOR		ITEM SUBSTITUTION LIST		
PART NUMBER	SAME AS	ITEM	ITEM DESCRIPTION	SUBSTITUTE PART NUMBER
8-2151332-2	2151332-2	1	WIRE CRIMPER	2370388-2
9-2151332-2	2-2151332-2	3	INSULATION CRIMPER	4-1803627-7
		46	BASIC SUB -ASSEMBLY	1803940-9
		141	BASIC SUB -ASSEMBLY	1-1803940-0
			LUBRICATOR	DELETE

PACIFIC VERSION
Shown on sheets 3 of 4 & 4 of 4
(Atlantic version shown on sheets 1 of 4 & 2 of 4)

LOC	DIST	REVISIONS					
A	66	P	LTN	DESCRIPTION	DATE	DWN	APVD
		-		SEE SHEET 1		-	-

-	1	1	1803945-4	TONKER			300
-	1	1	22278-9	SPRING, COMPRESSION			299
-	2	2	4-18032-3	SCR, SET, FLT PNT, M3 X 6.0			298
-	1	1	1803944-1	SPACER, TONKER			297
-	1	-	2844950-1	AIR FEED MODULE			290
-	1	1	2119791-9	DEPRESSOR, WIRE			286
-	1	1	1-22281-8	SPRING, COMPRESSION			262
-	1	1	2168083-6	SCR, SKT HD CAP, RoHS, M5 X 65			261
-	1	1	2119082-5	CAM, SNAIL, INSULATION ADJUSTMENT			244
-	1	1	2079764-1	WASHER, WAVE SPRING, CREST-TO-CREST			243
3	-	1	2119083-1	RETAINER, INSULATION DIAL			242
-	-	1	2844940-1	AIR FEED MODULE			238
-	REF	REF	994970-2	COUNTER, MAGNETIC			164
5	-	1	2119641-2	FEED CAM, AIR FEED			151
-	1	1	2168083-8	SCR, SKT HD CAP, RoHS, M4 X 16			144
-	4	4	2168083-9	SCR, SKT HD CAP, RoHS, M4 X 20			143
-	1	1	1-1803583-0	APPLICATOR BASIC ASSEMBLY, SF			141
-	1	1	1803516-1	RAM ASSEMBLY, SF PACIFIC			140
6	-	1	2119955-1	ASSY, LUBRICATOR, SIDE FEED			113
-	1	1	2844908-1	SCREW, LOCKING			99
-	1	1	2844907-1	POST, LOCKING			98
-	1	1	1-690438-0	FRONT STRIP GUIDE			96
-	2	2	2168083-1	SCR, SKT HD CAP, RoHS, M3 X 8.0			95
-	1	1	455888-4	SPACER, CRIMPER			82
-	1	1	1803607-3	DOCUMENTATION PACKAGE			71
-	1	1	2119791-9	DEPRESSOR, WIRE			70
-	1	1	2119740-1	TAG, IDENTIFICATION			67
-	2	2	2168078-1	SCREW, DRIVE, RH, RoHS, 2 x .188			66
-	1	1	2-18032-5	SCR, SET, FLT PNT, M5 X 20.0			64
-	1	1	2-1722335-1	THREAD BOLT GEWINDEBOLZEN			61
-	1	1	5-18022-5	SCR, HEX HD CAP, M4 X 6.0			59
-	1	1	1338685-1	PAWL, FEED			56
5	-	2	2168083-8	SCR, SKT HD CAP, RoHS, M4 X 16			53
-	-	1	18023-9	SCR, SKT HD CAP M4 X 6.0			49
-	1	1	1803602-1	SCR, BHSC, RoHS (M8 X 25)			41
-	1	1	1752356-3	SUPPORT, TERMINAL			34
-	2	2	2079383-5	SCR, BHSC, RoHS (M4 X 20)			33
-	2	2	2-2844962-4	SPACER, CYLINDRICAL, STRIP GUIDE			30
-	1	1	2844938-1	PLATE, STRIP GUIDE			29
-	2	2	22283-1	SPRING, COMPRESSION			27
-	1	1	356835-1	LEVER, DRAG RELEASE			26
-	1	1	1803142-1	DRAG, TERMINAL			25
-	1	1	1320928-2	STRIP GUIDE			24
-	1	1	980371-4	SCR, SKT HD SHLDR 5.0 DIA X 6.0			23
-	1	1	2168083-2	SCR, SKT HD CAP, RoHS, M4 X 8.0			21
-	2	2	1-18028-2	WASHER, FLAT, REG M4			20
-	1	1	2119533-1	STRIPPER, SIDE FEED			19
-	1	1	3-22280-3	SPRING, COMPRESSION			12
-	1	1	2-519000-1	SCR, SKT HD CAP M4 X 10.0			11
7	-	1	2119805-1	SHEAR HOLDER, FRONT			10
7	-	1	2-1803095-3	FLOATING SHEAR, FRONT			9
7	1	1	1633689-5	ANVIL, COMBINATION			8
-	1	1	2-240641-4	SPACER			7
-	1	1	1-2119757-8	DEPRESSOR, SHEAR			5
-	1	1	6-238011-0	BLOCK, CRIMPER SPACER			4
7	1	1	4-1803019-7	CRIMPER, INSULATION O			3
-	-	-	-	-			2
7	1	1	1803697-2	CRIMPER, WIRE PREMIUM, STEPPED			1

DIMENSIONS: mm		TOLERANCES UNLESS OTHERWISE SPECIFIED:		DWN C. CHEN 05MAY2011		CHK S. XI 05MAY2011		APVD J. CRUZ 05MAY2011		NAME	
0 PLC ±		1 PLC ±		2 PLC ±		3 PLC ±		4 PLC ±		RESTRICTED TO	
MATERIAL		FINISH		WEIGHT		SCALE		SHEET		REV	
-		-		-		1:2		3 OF 4		AB	

Customer Accessible Production Drawing

LOC	DIST	REVISIONS					
A	66	P	LTN	DESCRIPTION	DATE	OWN	APVD
		-		SEE SHEET 1			

FEED TYPE PNEUMATIC

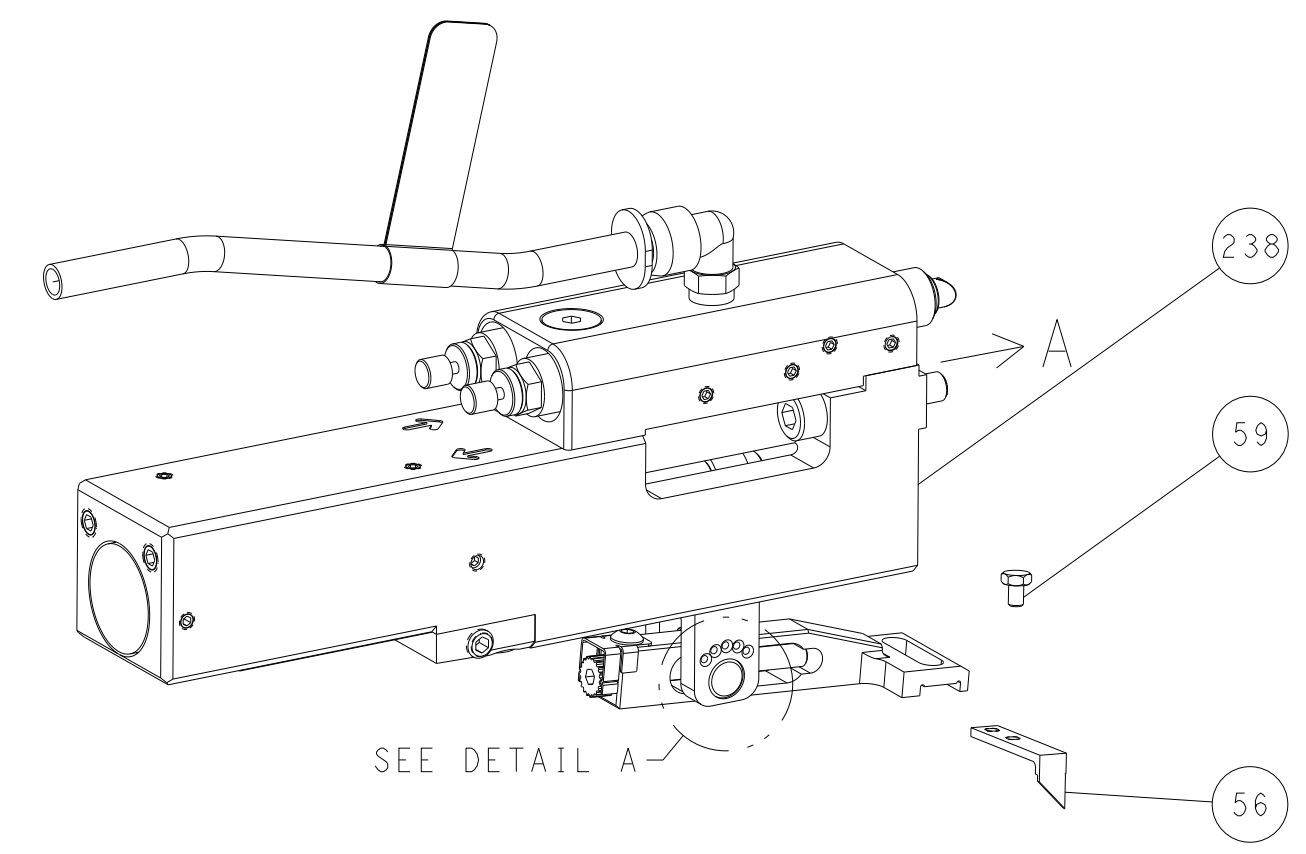

FEED SPRING SETTING POSITION (SHOWN FROM REAR SIDE)

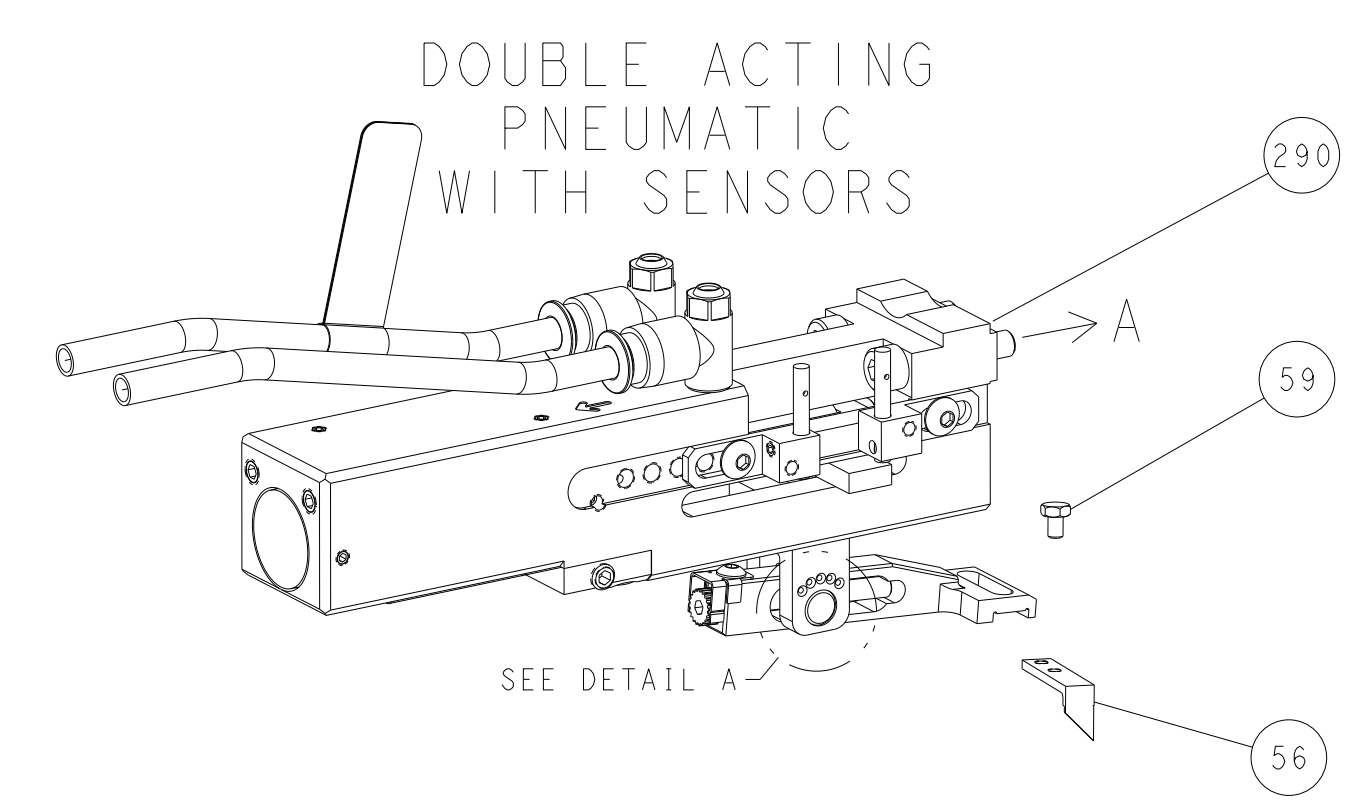
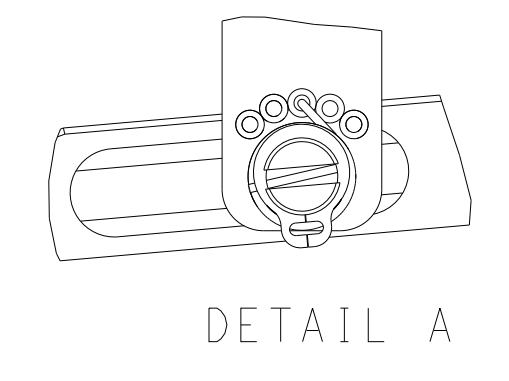

CAM POSITION

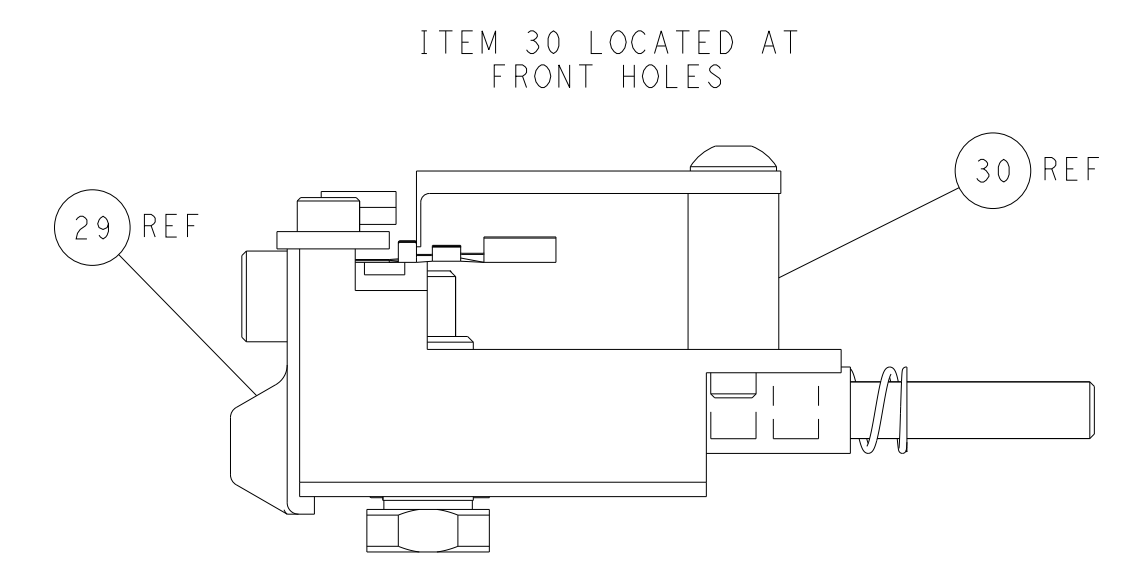
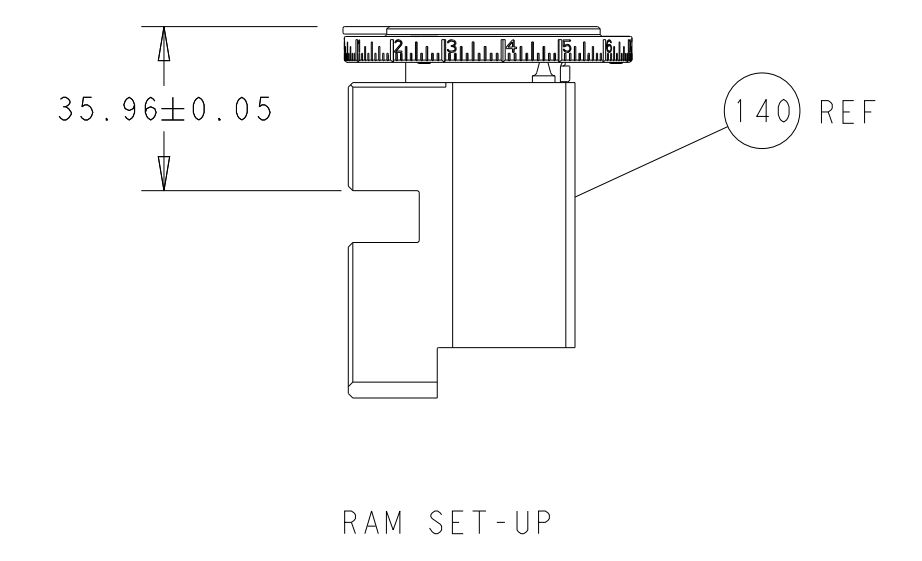
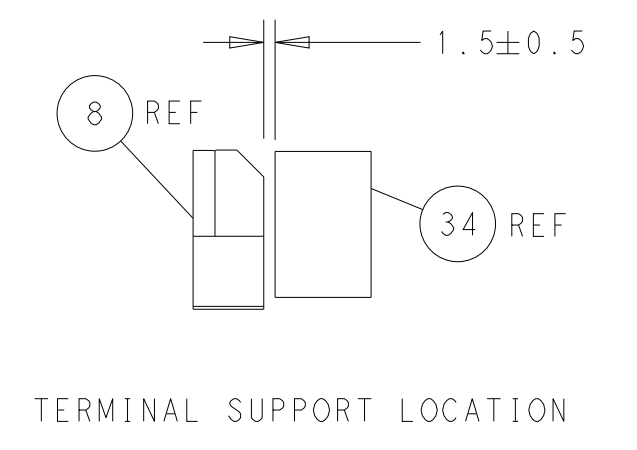
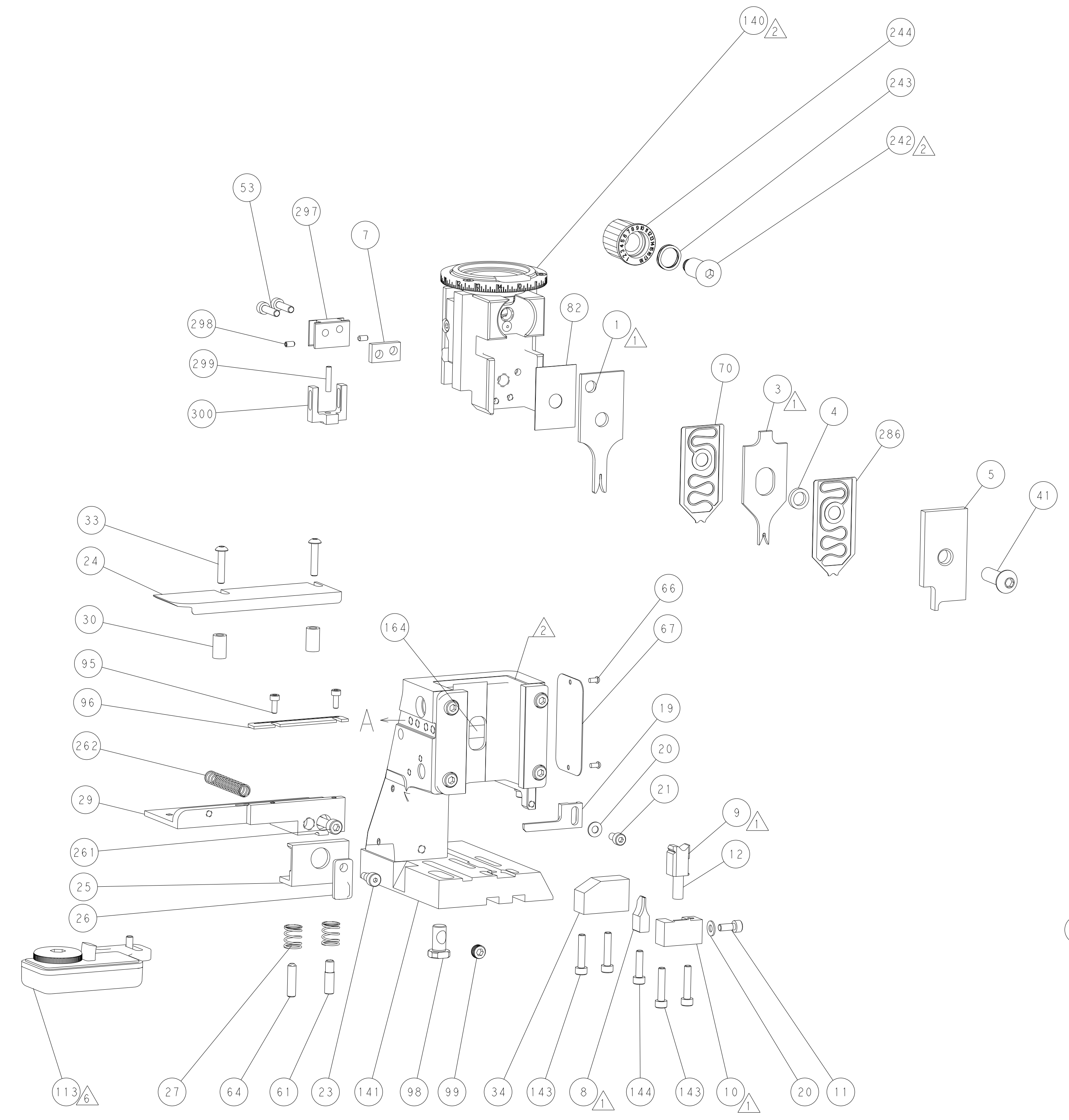
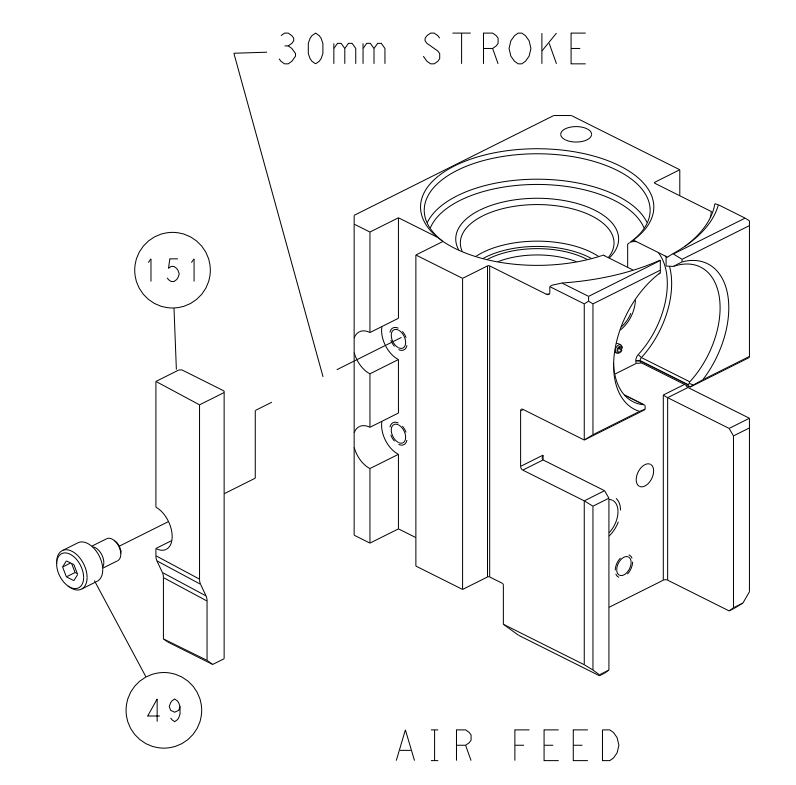

PACIFIC VERSION
 Shown on sheets 3 of 4 & 4 of 4
 (Atlantic version shown on sheets 1 of 4 & 2 of 4)

<small>THIS DRAWING IS UNPUBLISHED. RELEASED FOR PUBLICATION. ALL RIGHTS RESERVED. © 2011 BY TYCO ELECTRONICS CORPORATION.</small>		DWN: C. CHEN 05MAY2011 CHK: S. XI 05MAY2011 APVD: J. CRUZ 05MAY2011	TE Connectivity Harrisburg, PA 17105-3608
DIMENSIONS: mm TOLERANCES UNLESS OTHERWISE SPECIFIED: 0 PLC ± 1 PLC ± 2 PLC ± 3 PLC ± 4 PLC ± ANGLES ± FINISH		NAME: Ocean Side Feed Applicator SIZE: A1 CAGE CODE: 00779 DRAWING NO: 2151332 SCALE: 1:2 SHEET: 4 OF 4 REV: AB	RESTRICTED TO:
MATERIAL:		WEIGHT:	Customer Accessible Production Drawing