

REVISION

ZONE	LTR	ECN	DESCRIPTION	DATE	APPROVED
	A	37953	NEW RELEASE	7/7/88	<i>[Signature]</i>
	B	4134	UPDATE NOTE 1.	3/12/02	TC

.060-80 UNC-2A THD
(CAP SCREW) STAINLESS STEEL
PASSIVATED

PIN CONTACT.
COPPER ALLOY, GOLD PLTD

.035 TYP
.015

.300 REF

INSULATOR, GLASS
FILLED NYLON,
COLOR BLUE

.050 MAX EPOXY
WICKING ON SOLDER POTS

SOLDER POT
BRASS, GOLD PLTD
SHROUD

.135 MAX

#6
Ø12 MAX

45°
#6

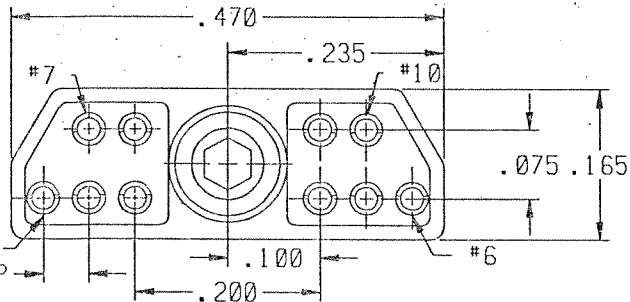

Tyco Dwg 3-1532150-3
Micro P/N 095-0573-0964

NOTES: UNLESS OTHERWISE SPECIFIED

- ▲ MARK PER TIS.
- ▲ EPOXY AS SHOWN USE 194-8102-6215/6225.
- 3. CRIMP SOLDER POTS INTO CONTACTS PER MEP 302-05.
- 4. NO SCRATCHES SHOWING BASE METAL PERMITTED ON SOLDER POTS.
- 5. ORIENT SOLDER POT OPENNINGS PARALLEL TO SIDES OF INSULATOR WITHIN 20°.
- ▲ ROLL SHROUD OVER AS SHOWN. SCREW MUST ROTATE FREELY.

UNLESS OTHERWISE SPECIFIED DIMENSIONS ARE IN INCHES. TOLERANCE ARE:		APPROVALS		 MALCO A MICRODOT COMPANY, INC. 306 PASADENA AVE., SO. PASADENA, CA 91030
FRACTIONS	DECIMALS	ANGLES	SIGNATURE	
± 1/32	.XX ± .03 .XXX ± .010	± 2°	<i>[Signature]</i>	7/7/88
MATERIAL:		CHECKED		
		PROJ. ENG.		
		APPROVED		
FINISH:		THIS DOCUMENT IS THE PROPERTY OF MALCO, A MICRODOT CO. USE OF THIS DOCUMENT OR ANY PART OF THEREOF IS STRICTLY FORBIDDEN WITHOUT THE EXPRESS WRITTEN PERMISSION OF MALCO, A MICRODOT COMPANY.		JACKMATE CONNECTOR MCJ BX-10PS (FULL COMPLEMENT OF CONTACTS)
		SIZE	CODE IDENT NO.	DRAWING NO.
		A	98278	095-0573-0964
		SCALE: NONE	SHEET 1 OF 1	