

DATA SHEET

2322 661 97...

Surface mount PTC thermistors for overload protection

Product specification
Supersedes data of 17th May 1999
File under BCcomponents, BC02

2001 Feb 14

Surface mount PTC thermistors for overload protection

2322 661 97...

FEATURES

- Ideal for pick-and-place circuit assembly
- Low mounting height
- Suitable for reflow soldering
- Small ceramic diameter for faster response
- Low heat transfer to substrate
- Flat terminations for stable positioning and good solderability.

APPLICATIONS

- Telecom
 - Central office switching (C.O.)
 - Subscriber terminal equipment (T.E.)
 - Set top box
 - Modems
 - Cable TV communications
- General industry and automotive
 - Low power supplies overload protection
 - Data bus protection.

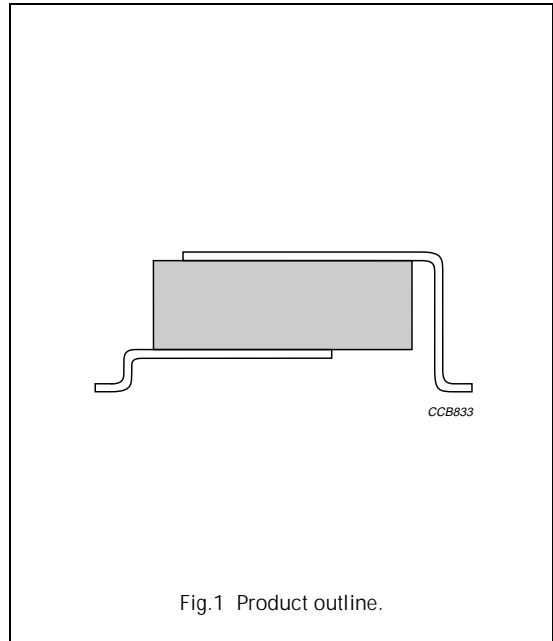

DESCRIPTION

The component consists of a high-performance PTC ceramic disc mounted in a lead-frame for direct soldering onto a printed-circuit board (PCB) or substrate.

The ceramic is soldered to the leadframe by a local reflow process, during which the solder layer is melted to the metallized ceramic surface using a low residue flux.

QUICK REFERENCE DATA

DESCRIPTION	VALUE	
	STANDARD TYPES ⁽¹⁾⁽²⁾	TELECOM TYPES ⁽¹⁾⁽²⁾
Nominal R25	2 to 500 Ω	10 to 70 Ω
Resistance tolerance	$\pm 10\%$; $\pm 15\%$; $\pm 20\%$	
Maximum overload current (voltage dependent)	2 to 10 A	
Non-trip current	50 to 500 mA at 25 °C	50 to 100 mA at 70 °C
Maximum voltage	16 to 400 V (RMS)	220 to 600 V (RMS)
Response time at 25 °C and 20 W overload power	<1 s	
Matching	–	down to 0.5 Ω
Maximum continuous power at 25 °C	2 W	

Notes

1. Customized products between the resistance ranges are available on request.
2. Coated and/or reinforced types are available on request.

Surface mount PTC thermistors for overload protection

2322 661 97...

SOLDERING CONDITIONS

This SMD thermistor is only suitable for reflow soldering, in accordance with "CECC 00802". Soldering processes which can be used are reflow (infrared and convection heating) and vapour phase. The maximum temperature of 260 °C during 10 s should not be exceeded and no liquid flux should be allowed to reach the ceramic body.

Typical examples of a soldering processes that will provide reliable joints without damage, are shown in Figs 2 and 3.

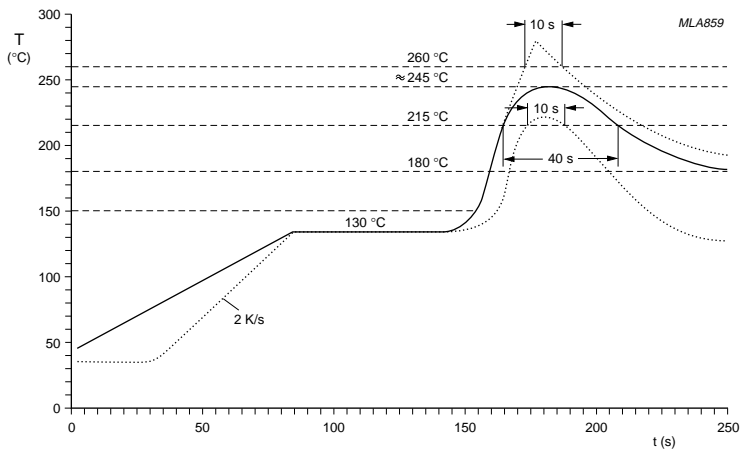

Typical values (solid line).
Process limits (dotted lines).

Fig.2 Reflow soldering.

Surface mount PTC thermistors for overload protection

2322 661 97...

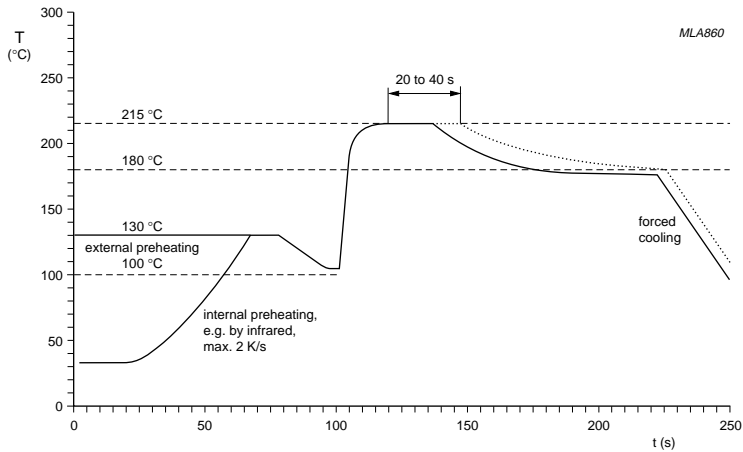

Typical values (solid line).
Process limits (dotted line).

Fig.3 Vapour phase soldering.

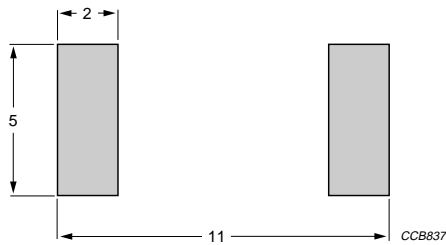

Dimensions in mm.

Fig.4 Dimensions of the solder lands.

Surface mount PTC thermistors for overload protection

2322 661 97...

MECHANICAL DATA

Table 1 Material information; see Fig.5

REF.	DESCRIPTION	MATERIAL AND REMARKS
1	ceramic	BaTiO ₃ doped
2	metallization	NiCr Ag layer (vacuum deposition)
3	leadframe	Ni plated phosphor bronze material covered by PbSn8 solder layer

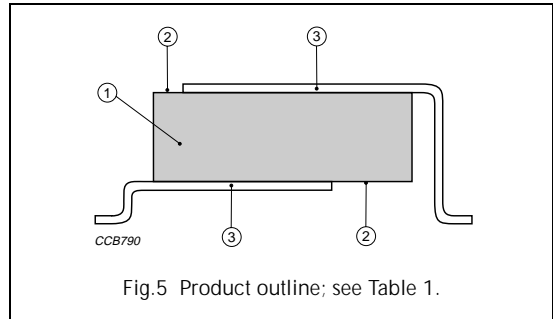

Marking

- All SMD PTCs are marked with the last 3-digits of the type number and a date code (YYWW).

Handling precautions

The special leadframe construction and the applied processes do not allow high handling forces on the component. Because of the nature of PTC ceramic material the component should not be touched with bare hands, as the residue of perspiration can influence component behaviour at high temperatures.

Handling forces vertically applied to the centre of the component should be limited to 5 N in the non-soldered condition and to 10 N in the soldered. These forces should not be exceeded during the handling, transportation and packaging of the soldered product.

For those applications where higher handling forces can be present, a re-inforced version is available on request.

Surface mount PTC thermistors for overload protection

2322 661 97...

PTC outlines

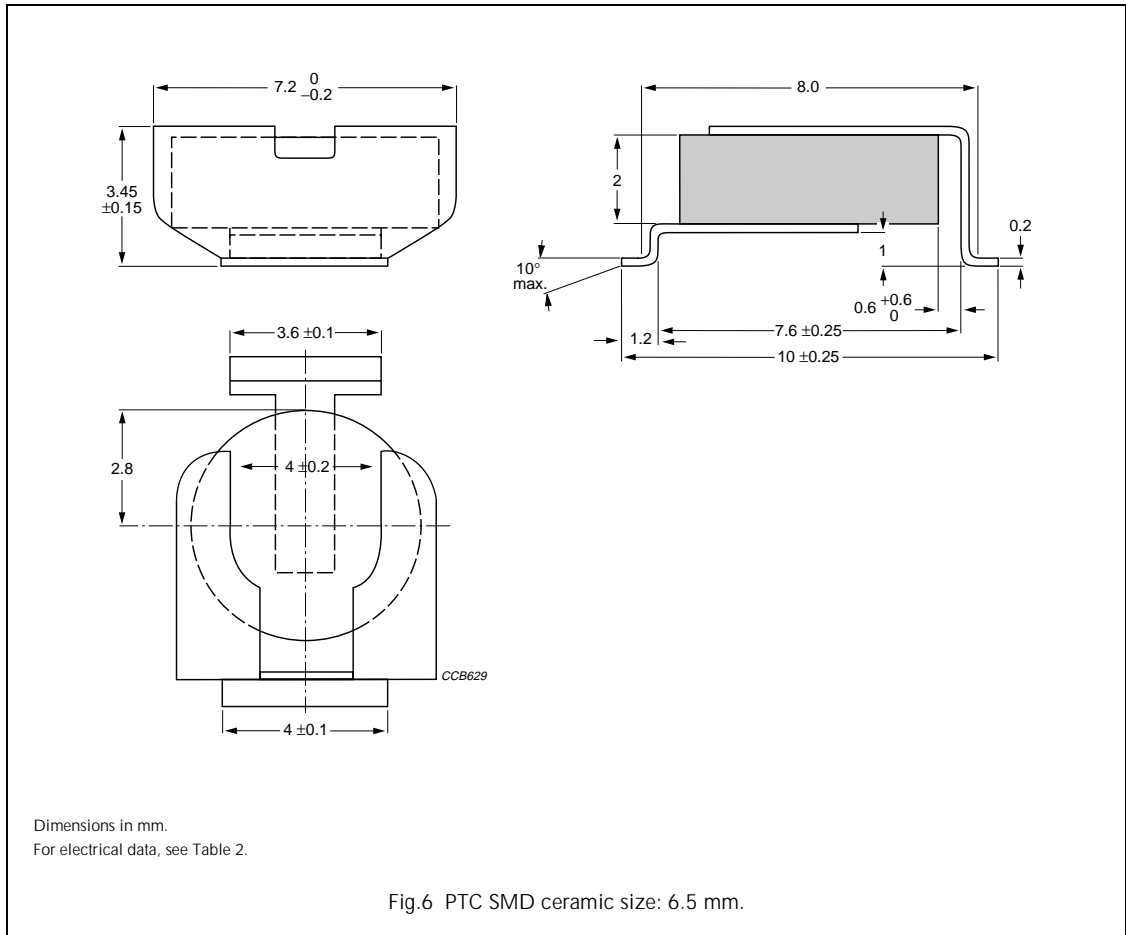

Surface mount PTC thermistors for overload protection

2322 661 97...

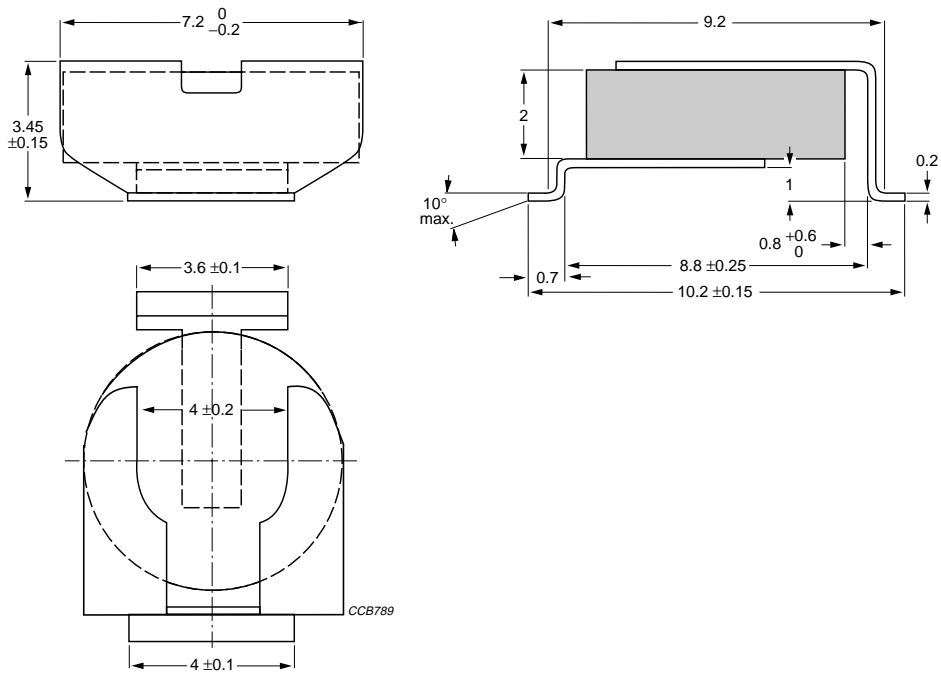

Dimensions in mm.
For electrical data, see Table 2.

Fig.7 PTC SMD ceramic size: 7.1 mm.

Surface mount PTC thermistors for overload protection

2322 661 97...

ELECTRICAL DATA

Table 2 Ceramic size: 6.5 and 7.1 mm; see Figs 6 and 7

R ₂₅		V MAX. (V)	I _{nt} at		I _t at	MAX. TRIP-TIME		MATCHED PAIRS AVAILABLE	CERAMIC SIZE (mm)	CATALOGUE NUMBER 2322 661
(Ω)	(%)		25 °C	70 °C	25 °C	t _t (s)	at I _t (mA)			
Telecommunication types; note 1										
40	25	265	80	50	130	2.5	500	no	6.5	97002
15 to 20 ⁽¹⁾	–	300	150	100	250	1.5	1000	0.5 Ω	6.5	97003
15 to 20 ⁽¹⁾	–	300	150	100	250	1.5	1000	no	6.5	97004
25 ⁽¹⁾	20	265	120	70	220	1.3	1000	1 Ω	6.5	97005
35 ⁽¹⁾	+15/–20	425	110	70	175	1.0	1000	1 Ω	6.5	97009
10 ⁽¹⁾	20	245	165	100	270	3.0	1000	no	6.5	97012
10 ⁽¹⁾	20	245	165	100	270	3.0	1000	0.5 Ω	6.5	97016
20 ⁽¹⁾	20	300	120	70	250	1.4	1000	0.5 Ω	6.5	97018
50	20	425	90	60	150	0.8	1000	1 Ω	6.5	97019
10 ⁽¹⁾	20	300	150	100	250	3.0	1000	0.5 Ω	7.1	97203
25 ⁽¹⁾	20	400	120	70	220	2.0	1000	1 Ω	7.1	97204
50 ⁽¹⁾	20	600	70	40	140	0.7	1000	1 Ω	7.1	97205
General industrial types										
9.4 ⁽¹⁾	25	60	150	100	300	4.0	600	–	6.5	97011
3.3 ⁽¹⁾	25	24	400	–	650	6.0	1000	–	6.5	97013

Note

1. These types pass "ITU-T K20/21" telecommunication protection recommendation.

Surface mount PTC thermistors for overload protection

2322 661 97...

PACKAGING

Tape specifications

All tape and reel specifications are in accordance with "IEC 60286-3". Basic dimensions are given in Figs 8 and 12, and Tables 3 and 4. Carrier tape material is conductive polystyrene or polycarbonate.

Blister tape

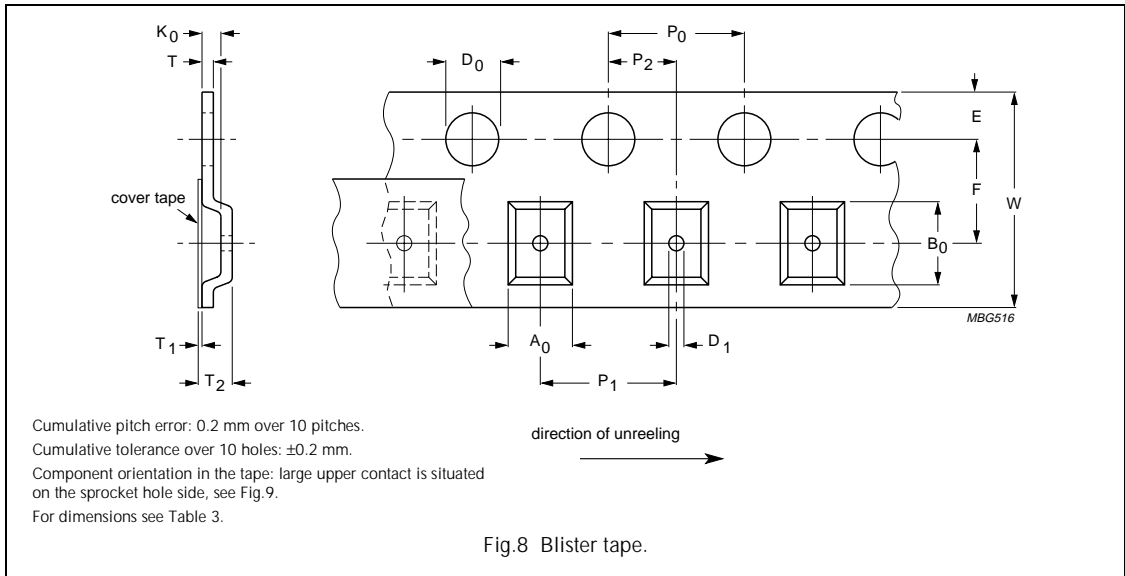

Table 3 Dimensions of blister tape, in millimetres; see Fig.8

SYMBOL	PRODUCT SIZE CODE	TOL.
A_0 ; note 1	7.5	± 0.1
B_0 ; note 1	10.5	± 0.1
K_0	4.1	± 0.1
W	16	± 0.3
E	1.75	± 0.1
F	7.5	± 0.1
D_0	1.5	+0.1/-0.0
D_1	1.5	+0.1/-0.0
P_0 ; note 2	4	± 0.1
P_1	12	± 0.1
P_2	2	± 0.1
T tape thickness	0.3	± 0.03
T_1 cover tape	0.05	-
T_2	4.6	max.

Notes

1. Measured 0.3 mm above base pocket.
2. P_0 pitch tolerance over any 10 pitches is ± 0.2 mm.

Surface mount PTC thermistors for overload protection

2322 661 97...

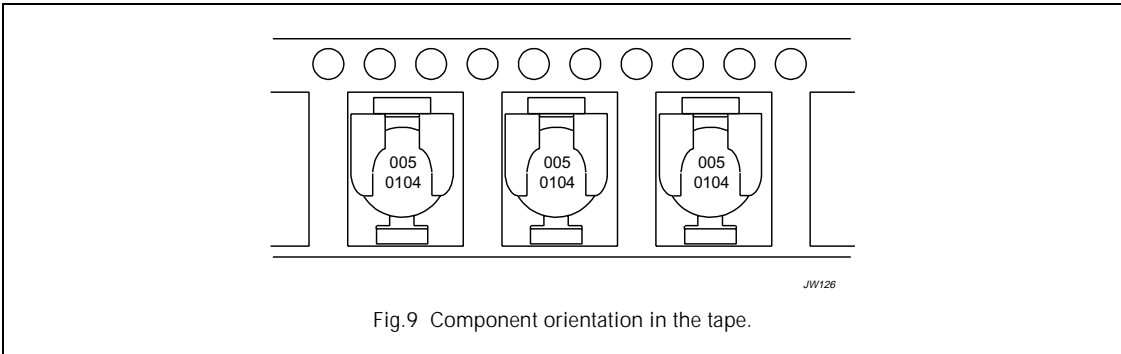

Fig.9 Component orientation in the tape.

Leader/trailer tape specification

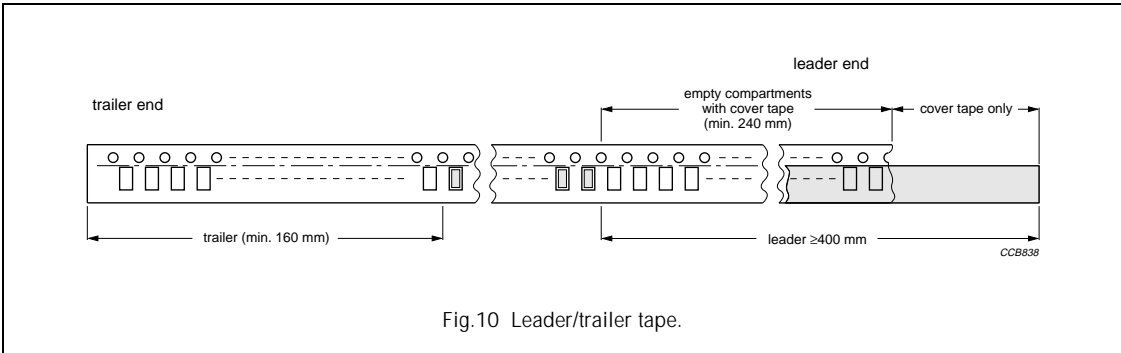

Fig.10 Leader/trailer tape.

Taping package requirements

Component is free and not sticking to top and/or bottom tape.

Component should be easy to remove from carrier tape.

Peel-off force

Peel-off force of blister tape is in accordance with "IEC 60286-3"; that is, 0.1 to 1.3 N at a peel-off speed of 300 mm/minute.

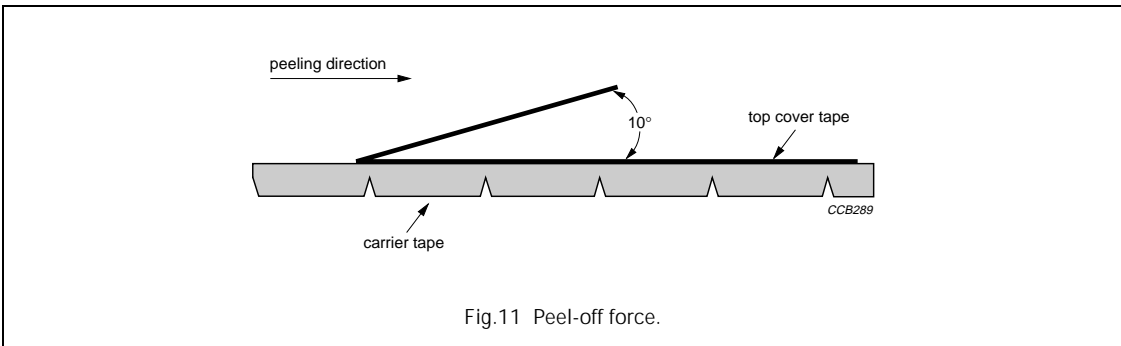

Fig.11 Peel-off force.

Surface mount PTC thermistors for overload protection

2322 661 97...

Reel specifications

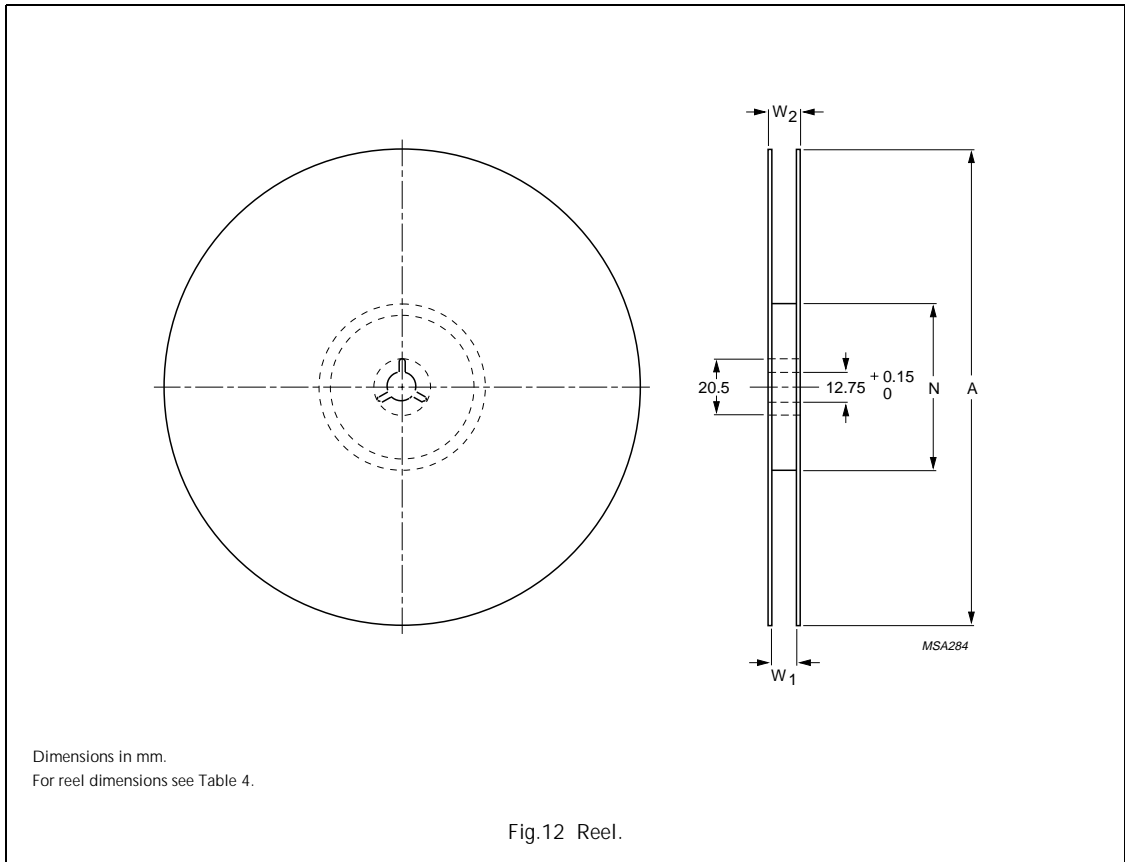

Table 4 Reel dimensions; see note 1 and Fig.12

PRODUCT SIZE CODE	UNITS ⁽²⁾ PER REEL	TAPE WIDTH (mm)	A (mm)	N (mm)	W ₁ (mm)	W ₂ MAX. (mm)
4028	1500	16	330	62	16.4	20.4

Notes

1. Reels are packed in sealed plastic bags for protection against high humidity and corrosive atmospheres.
2. For matched components it is possible to have a maximum of one incomplete reel per resistance group. The minimum packaging quantity will be 500 units, with an even 100 up to 1400.