

THIS DRAWING IS UNPUBLISHED. RELEASED FOR PUBLICATION
 © COPYRIGHT - By - ALL RIGHTS RESERVED.

REVISIONS					
P	LTR	DESCRIPTION	DATE	DWN	APVD
	H	REVISED PER ECR-13-001204	24JUN13	KH	PD
	H1	REVISED PER ECR-16-004258	25MAR16	JJ	TD

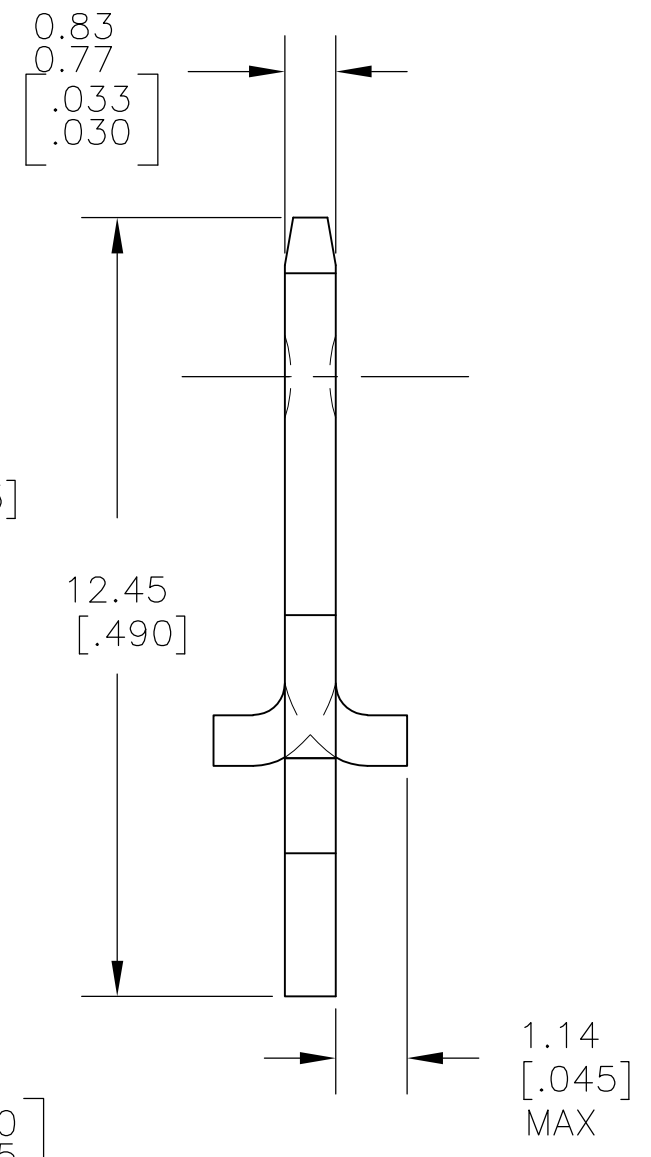

- 1 CONTINUOUS STRIP ON REELS.
- 2 TIN PLATE 0.00381 [.000150] MIN OVER 0.00254 [.000100] MIN THK COPPER OR TIN PLATE 0.00381 [.000150] MIN OVER 0.00127 [.000050] MIN THK NICKEL.
- 3 LOOSE PIECE TYPE.
- 4 PREPRODUCTION FASR REQUIRED.

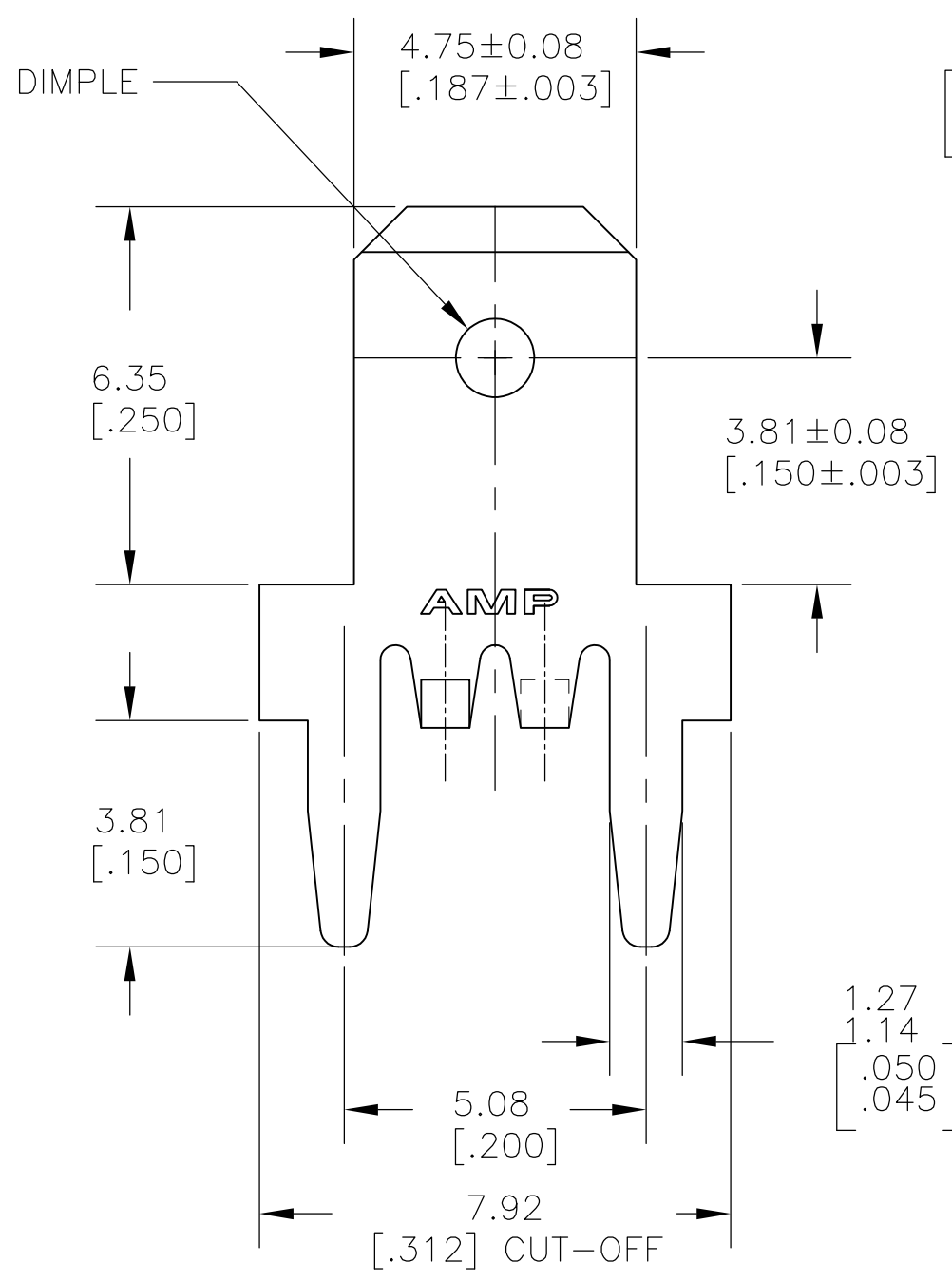
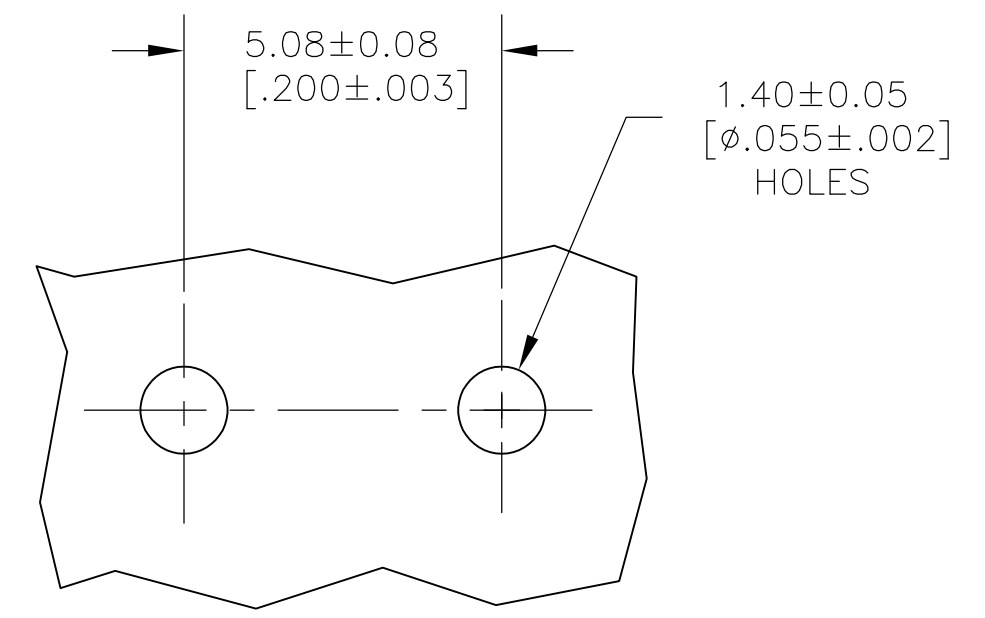

P.C. BOARD HOLE PATTERN

4	3	63860-2
	1	63860-1
		PART NO.

THIS DRAWING IS A CONTROLLED DOCUMENT.		DWN	JR RUTH	13FEB01	TE Connectivity		
DIMENSIONS: mm [INCHES]		CHK	MS FEHER	20FEB01			
TOLERANCES UNLESS OTHERWISE SPECIFIED:		APVD	N DEIBERT	20FEB01	TAB, FASTON, P.C.BOARD		
0 PLC ± -		PRODUCT SPEC		4.75 [.187]			RESTRICTED TO
1 PLC ± -		APPLICATION SPEC		-			SIZE
2 PLC ± 0.25 [.010]		-		-			CAGE CODE
3 PLC ± -		-		-			DRAWING NO
4 PLC ± -		-		-			WEIGHT
ANGLES ± -		-		-			A3 00779
FINISH		-		-			G-63860
MATERIAL		-		-			SCALE
BRASS		-		-			8:1
		-		-			SHEET
		-		-			1 OF 1
		-		-			REV
		-		-			H1