

DO NOT  
SCALE FROM  
THIS PRINT

RECEPTACLE  
SIZE

LEAD STYLE  
-02: 12 POS, 28 AWG

PLATING SPECIFICATION  
-L: 10µ" GOLD IN CONTACT AREA

END 2 (SEE TABLE 1)  
-BC: BLUNT CUT  
-01: 2 x 6 SFSD  
(PIN 1 TO PIN 1)

END 1  
-S: SOCKET

ASSEMBLED LENGTH  
XX.XX (IN METERS)  
(0.10 METER MIN TO  
50.00 METER MAX)

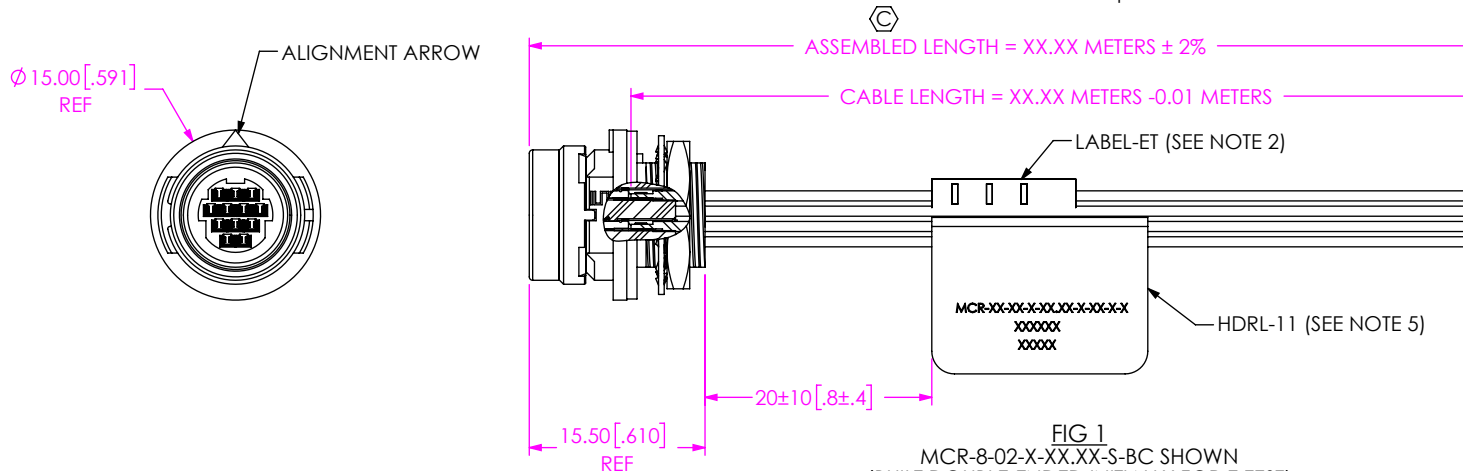

FIG 1  
MCR-8-02-X-XX.XX-S-BC SHOWN  
(BUILT DOUBLE-ENDED INITIALLY FOR E-TEST)

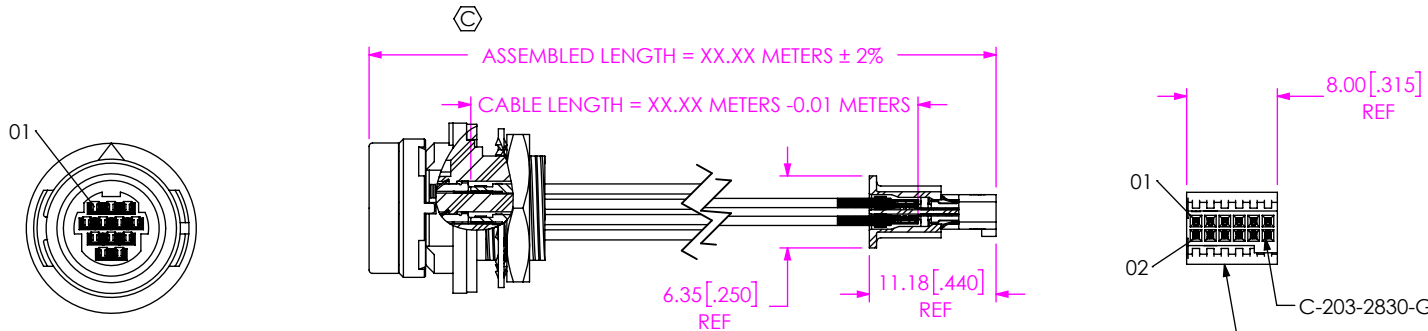
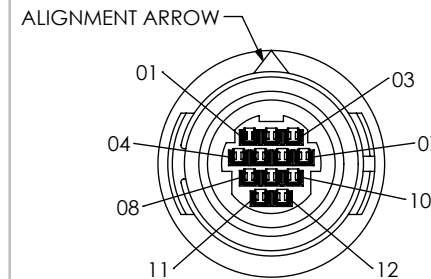

FIG 2  
MCR-8-02-X-XX.XX-S-01 SHOWN  
(PIN 1 TO PIN 1)  
(DIFFERENT AS SHOWN, OTHERWISE SAME AS FIG 1)

END 1 OPTIONS

12 POSITION  
(-S: SOCKET)



NOTES:

1. Ⓢ REPRESENTS A CRITICAL DIMENSION.
2. ASSEMBLY TO BE 100% TESTED FOR CONTINUITY, ISOLATION, & HI-POT AT 300V. (1) LABEL-ET TO BE APPLIED AFTER FINAL ELECTRICAL TEST.
3. ASSEMBLIES TO BE BULK PACKAGED PER PACKAGING STANDARD CO-RF-WI-3001-M.
4. SIGNAL MAPPING IS 1 TO 1, 2 TO 2, 3 TO 3, etc..
5. PLACE HDRL-11 (LABEL) ON CABLE WHERE SHOWN. LABEL TO CONTAIN  
LINE 1 - PART NUMBER "MCR-8-XX-X-XX.XX-X-XX"  
LINE 2 - SHOP ORDER NUMBER "XXXXXX"  
LINE 3 - DATE CODE "XXXXXX"
6. PANEL THICKNESS RANGE: 0.70[0.027] - 3.00[0.118].
7. WHEN MOUNTING PRODUCT TO PANEL TORQUE PN-30-8 TO 0.8 Nm[7.08 IN-LBS].
8. CONTACTS MUST BE INSERTED UNTIL RETENTION FEATURE LOCKS INTO PLACE.
9. REFER TO CRIMP-SPECIFICATIONS PRINT FOR CRIMP AND STRIP DIMENSIONS, TOLERANCES, TOOLING, AND ITS REQUIREMENTS.
10. -S (SOCKET): REFERENCE DC-MCR-8 PRINT FOR SOCKET DUSTCAP

UNLESS OTHERWISE SPECIFIED,  
DIMENSIONS ARE IN MILLIMETERS.  
TOLERANCES ARE:  
DECIMALS ANGLES  
X.X: ±0.3 [.01] 2°  
X.XX: ±0.13 [.005]  
X.XXX: ±0.051 [.0020]

PROPRIETARY NOTE

THIS DOCUMENT CONTAINS CONFIDENTIAL AND PROPRIETARY INFORMATION AND ALL DESIGN, MANUFACTURING, REPRODUCTION, USE, PATENT RIGHTS AND SALES RIGHTS ARE EXPRESSLY RESERVED BY SAMTEC, INC. THIS DOCUMENT SHALL NOT BE DISCLOSED, IN WHOLE OR PART, TO ANY UNAUTHORIZED PERSON OR ENTITY NOR REPRODUCED, TRANSFERRED OR INCORPORATED IN ANY OTHER PROJECT IN ANY MANNER WITHOUT THE EXPRESS WRITTEN CONSENT OF SAMTEC, INC.

MATERIAL: DO NOT SCALE DRAWING SHEET SCALE: 3:2  
INSULATOR, C-RING: PPS  
CONTACTS: PHOS BRONZE  
GASKET: NEOPRENE RUBBER  
LOCK WASHER: PHOS BRONZE, NI PLATED  
HEX NUT: BRASS, NI PLATED

**samtec**

520 PARK EAST BLVD, NEW ALBANY, IN 47150  
PHONE: 812-944-6733 FAX: 812-948-5047  
e-Mail: info@SAMTEC.com code 53322

DESCRIPTION:  
MINI CIRC. PANEL ASSEMBLY

DWG. NO.  
MCR-8-02-X-XX.XX-X-XX

BY: J. BORGELT 4/11/2013 SHEET 1 OF 2

REVISION F

**IN-PROCESS 1**  
 CUT CABLE TO LENGTH SHOWN  
 (CABLE LENGTH FORMULA HAS ADDER  
 FOR BUILDING CABLE DOUBLE ENDED)  
 (SEE NOTE 6)

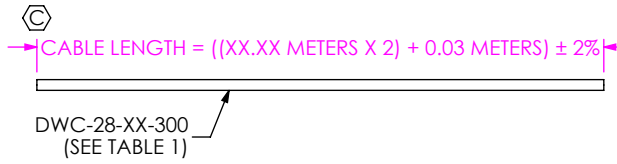

TABLE 1				
POSITION	-BC		-01	
	COLOR	DWC-XX-XX-XXX	COLOR	DWC-XX-XX-XXX
01	BROWN	DWC-28-01-300	BLACK	DWC-28-10-300
02	RED	DWC-28-02-300	BLACK	DWC-28-10-300
03	ORANGE	DWC-28-03-300	BLACK	DWC-28-10-300
04	YELLOW	DWC-28-04-300	BLACK	DWC-28-10-300
05	GREEN	DWC-28-05-300	BLACK	DWC-28-10-300
06	DARK BLUE	DWC-28-06-300	BLACK	DWC-28-10-300
07	VIOLET	DWC-28-07-300	BLACK	DWC-28-10-300
08	GRAY	DWC-28-08-300	BLACK	DWC-28-10-300
09	WHITE	DWC-28-09-300	BLACK	DWC-28-10-300
10	BLACK	DWC-28-10-300	BLACK	DWC-28-10-300
11	GREEN/BLACK	DWC-28-11-300	BLACK	DWC-28-10-300
12	TAN	DWC-28-12-300	BLACK	DWC-28-10-300

**IN-PROCESS 2**  
 STRIP CONDUCTORS



**IN-PROCESS 3**  
 CRIMP CONTACTS  
 (SEE NOTE 9)



**IN-PROCESS 4**  
 SLIDE PG-30-8, LW-30-8, & PN-30-8 COMPONENTS ONTO WIRES

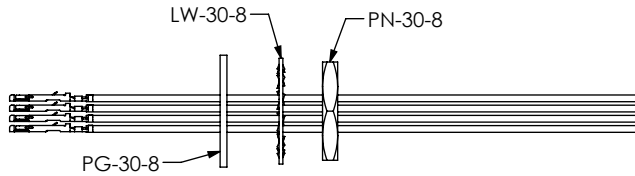

**IN-PROCESS 5**  
 INSERT CONTACTS INTO SUB-MCR-8-12 INSULATOR  
 UNTIL THEIR RETENTION FEATURES LOCK INTO PLACE.

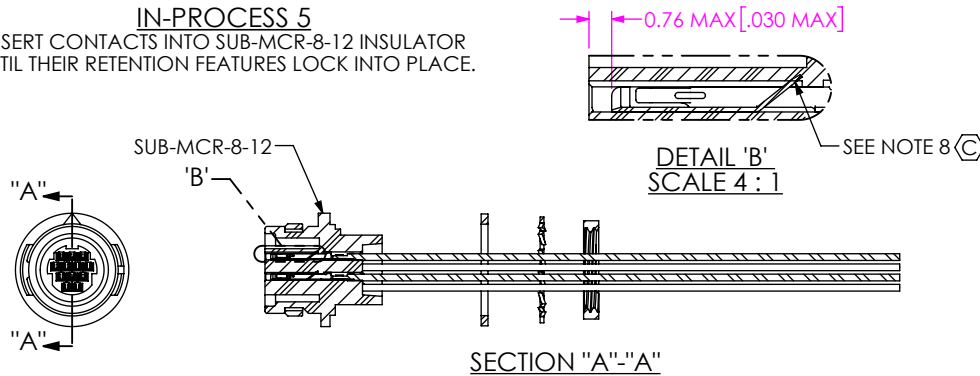

**IN-PROCESS 6**

SLIDE PG-30-8 FORWARD AND SEAT AGAINST FLANGE ON  
 SUB-MCR-8-12. SLIDE LW-30-8 FORWARD & LOOSELY THREAD  
 PN-30-8 ONTO SUB-MCR-8-12 TO HOLD ITEMS IN PLACE



**IN-PROCESS 7**

REPEAT STEPS 2-6 FOR END 2, E-TEST CABLE, APPLY  
 LABEL-ET & HDRL-11 TO BOTH ENDS, CUT CABLE IN  
 HALF & TRIM BOTH ENDS TO FINISHED LENGTH.

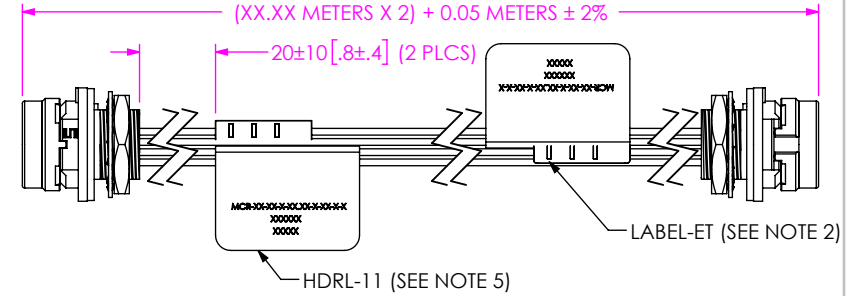

**RECOMMENDED PANEL OPENING**  
 (SEE NOTES 6 & 7)

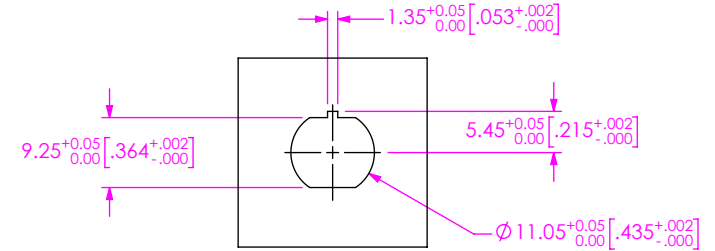

**PROPRIETARY NOTE**  
 THIS DOCUMENT CONTAINS CONFIDENTIAL AND  
 PROPRIETARY INFORMATION AND ALL DESIGN,  
 MANUFACTURING, REPRODUCTION, USE, PATENT RIGHTS  
 AND SALES RIGHTS ARE EXPRESSLY RESERVED BY SAMTEC,  
 INC. THIS DOCUMENT SHALL NOT BE DISCLOSED, IN WHOLE  
 OR PART, TO ANY UNAUTHORIZED PERSON OR ENTITY NOR  
 REPRODUCED, TRANSFERRED OR INCORPORATED IN ANY  
 OTHER PROJECT IN ANY MANNER WITHOUT THE EXPRESS  
 WRITTEN CONSENT OF SAMTEC, INC.

DO NOT SCALE DRAWING  
 SHEET SCALE: 1:1



520 PARK EAST BLVD, NEW ALBANY, IN 47150  
 PHONE: 812-944-6733 FAX: 812-948-5047  
 e-Mail info@SAMTEC.com code 55322

DESCRIPTION:  
 MINI CIRC. PANEL ASSEMBLY

DWG. NO.  
 MCR-8-02-X-XX.XX-X-XX

BY: J. BORGELT 4/11/2013 SHEET 2 OF 2