

**Order Number**  
**63808-2210**

# molex

## Application Tooling Specification

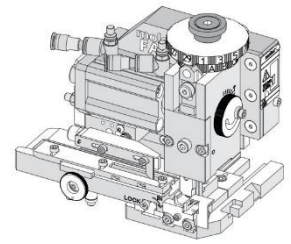

### FEATURES

- Applicator designed to industry-standard mounting and 135.80mm (5.346") shut height
- Quick setup time; plus, the crimp height, track and feed adjustments can be set without removing the applicator from the press
- Fine adjustment allows users to achieve target with little effort by adjusting in increments of 0.015mm (.0006") for conductor crimp height and 0.025mm (.001") for insulation height
- Independent adjustment rings allow users to quickly adjust the conductor or insulation crimp height without affecting each other
- Directly adapts to most automatic wire processing machines
- This applicator was designed for use in a wire processor only
- Fine adjustment of the bend is achieved using the bend adjust dial
- This applicator is configured with a pneumatic feed, which requires a 4-way pneumatic valve for operation

### SCOPE

**Products:** CTX50 Sealed Large Receptacle Terminals, 0.35mm<sup>2</sup> wire.

Terminal Series No.	Terminal Order No.	Wire		Insulation Diameter		Strip Length	
		Wire Type	Size	mm	In.	mm	In.
34905	34905-6447 34905-2447	FLR2X A3ZH-A	0.35mm <sup>2</sup>	1.20-1.40	.047-.055	3.80	.150

**CAUTION:** This applicator was designed for use in a wire processor only.

**CAUTION:** To operate the pneumatic feed, a 4-way pneumatic valve is required.

**DEFINITION OF TERMS**

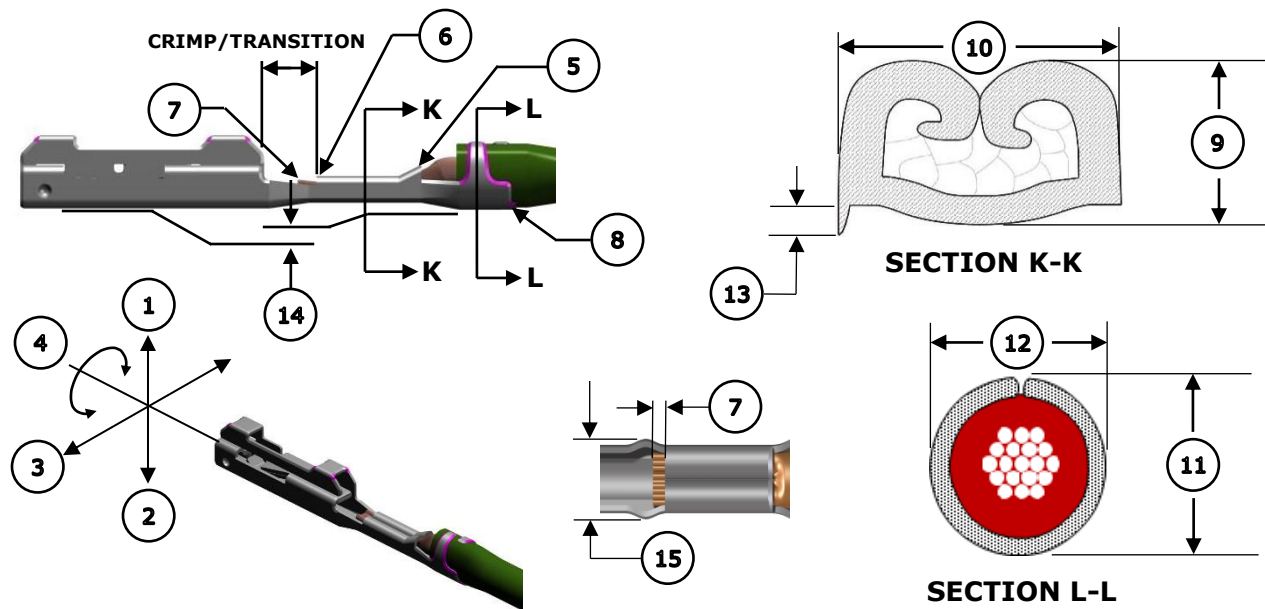

**CRIMP SPECIFICATIONS**

The following crimp specifications are based on document AS-34905-001 Rev. H:

Feature	Requirement				
<b>1. Bend Up</b>	1° Max				
<b>2. Bend Down</b>	1° Max				
<b>3. Twist</b>	2° Max				
<b>4. Roll</b>	Not Applicable				
<b>5. Bell Mouth Rear</b>	0.25-0.45mm (.010-.018")				
<b>6. Bell Mouth Front</b>	Not Applicable				
<b>7. Conductor Brush</b>	0.30-0.70mm (.012-.028")				
<b>8. Cut-Off Tab</b>	0.20mm (.008") Max				
<b>Conductor Crimp</b>	<b>Wire Type</b>	<b>Wire Size</b>	<b>9. Crimp Height</b>		<b>10. Crimp Width</b>
	FLR2X A3ZH-A	0.35 mm <sup>2</sup>	0.69-0.75mm	.027-.030 in.	1.09-1.15mm .043-.045 in.
<b>Insulation Crimp</b>	<b>Wire Type</b>	<b>Wire Size</b>	<b>11. Crimp Height</b>		<b>12. Crimp Width</b>
	FLR2X A3ZH-A	0.35 mm <sup>2</sup>	1.50-1.56mm	.059-.061 in.	1.32-1.38mm .052-.054 in.
<b>Pull Force</b>	<b>Wire Type</b>	<b>Wire Size</b>	<b>Minimum Force</b>		To be measured with no influence from the insulation crimp.
	FLR2X A3ZH-A	0.35 mm <sup>2</sup>	50 N	11.3 lb.	
<b>13. Conductor Anvil Flash</b>	0.10mm (.004") Max				
<b>14. Insulation Grip Step</b>	-0.135-0.065mm (-.005-.003")				
<b>15. Crimp Bulge</b>	1.25mm (.049") Max within crimp/transition area				

## NOTES

---

### Applicator Notes

- This applicator is for automatic wire processor use only.
- This applicator does not include a cutting insert.
- Installing a cutting insert will cause jamming in this applicator.

### CUTTING INSERT

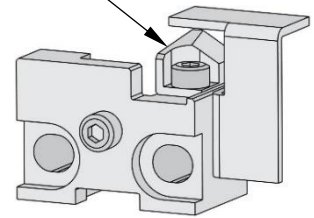

### Specification Notes

- It is very important that the brush length is consistently within specification for this sealed connector system to work properly.
- This applicator should only be run in a properly set up wire processor to consistently achieve the brush length.

### General Notes

1. Molex recommends that an extra perishable tooling kit be maintained at your facility.
2. Verify tooling alignment by hand cycling the press and applicator before crimping under power. Check that all screws are tight.
3. Slugs, terminals, dirt and oil should be kept clear of the work area.
4. Wear safety glasses at all times.
5. For recommended maintenance, refer to the FA2 manual (TM-638080200).
6. Molex recommends crimping stranded copper wire only.

## WARNINGS

---

**CAUTION:** This applicator must be installed in a press with a standard shut height of 135.80mm (5.346"). Tooling damage could result at a lower setting.

**CAUTION:** To prevent injury, never operate this applicator without the guards supplied with the press or wire-processing machine in place. Reference the press or wire processing manufacturer's instruction manual.

**CAUTION:** Molex tooling crimp specifications are valid only when used with Molex terminals and tooling manufactured by Molex and sold by Molex or authorized distributors ("Molex Tooling"). When using tooling other than Molex Tooling with Molex-specific connector systems listed in our ATS documents, the Molex Tooling qualification does not apply, and the responsibility for full qualification of the connector system is that of the customer. Molex accepts no liability for connector performance or tooling support where tooling other than Molex Tooling is used or where Molex Tooling is modified.

**PARTS LIST**

<b>Applicator 63808-2210</b>				
<b>Item</b>	<b>Order No.</b>	<b>Engineering No.</b>	<b>Description</b>	<b>Quantity</b>
<b>Perishable Tooling</b>				
	63808-2270	63808-2270	Tool Kit (All "Y" Items)	Ref
1	63454-0176	63454-0176	Insulation Punch	1 Y
2	63457-0133	63457-0133	Conductor Punch	1 Y
3	63456-0128	63456-0128	Insulation Anvil	1 Y
4	63455-0176	63455-0176	Conductor Anvil	1 Y
5	63443-0136	63443-0136	Cut-Off Plunger	1 Y
<b>Non-Perishable Components</b>				
6	63443-0118	63443-0118	Front Plunger Retainer	1
7	63700-0992	63700-0992	Cut-Off Plunger Spring	1
8	63443-0117	63443-0117	Front Scrap Chute	1
9	63443-7530	63443-7530	Anvil Mount	1
10	63443-0090	63443-0090	Wire Stop Assembly	1
11	63443-2803	63443-2803	Front Plunger Striker	1
12	63890-0140	63890-0140	Wire Hold Down Plunger	1
13	63600-4389	63600-4389	Wire Hold Down Spring	1
14	63600-5776	63600-5776	Nose Hold Down	1
15	63600-5775	63600-5775	Nose Hold Down Shank	1
16	63443-4703	63443-4703	Terminal Guide	1
17	63443-7403	63443-7403	Hold Down Block	1
18	63808-0229	63808-0229	Bend Adjust Dial	1
19	63808-0249	63808-0249	Feed Pawl	1
20	63443-4603	63443-4603	Carrier Cover	1
<b>Frame</b>				
21	63808-0200	63808-0200	Applicator Core	1
22	63808-0196	63808-0196	Pneumatic Feed Assembly	1
23	63808-0191	63808-0191	Track Assembly	1
<b>Hardware</b>				
24	—	—	M2.5 x 4 SHCS	1*
25	—	—	M3 Flat Washer Hard	1*
26	—	—	M3 Hex Nut	1*
27	—	—	M3 Inner Tooth Lock Washer	1*
28	—	—	M3 x 6 BHCS	2*
29	—	—	M3 x 12 SHCS	4*
30	—	—	M4 x 5 SSS	1*
31	—	—	M4 x 6 SHCS	1*
32	—	—	M4 x 50 SHCS	2*
33	—	—	M5 x 12 SHCS	1*
34	—	—	M5 x 12 Long Cup Point SSS	1*
35	—	—	M5 Hex Jam Nut	1*
*Fastener parts can be purchased through most industrial suppliers by using the description in the table above.				

**ASSEMBLY DRAWING**

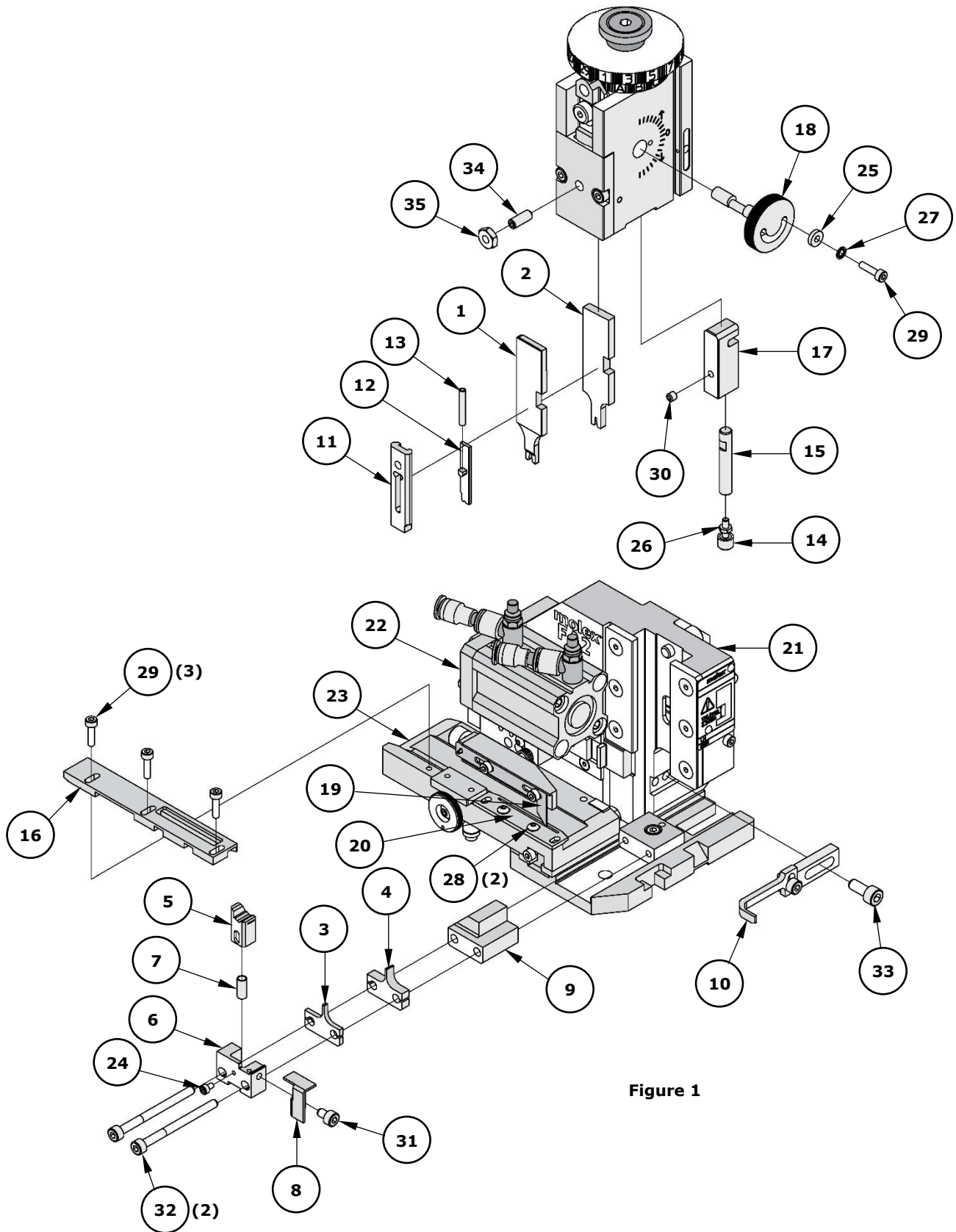

## FACTORY SETTINGS

### Feed Pawl Assembly

The FA2 applicator number 63808-2210 ships with the following factory settings. See Figure 2:

- The feed pawl shaft and M3 screw that holds the feed pawl spring are in position 3.
- The pin is in position B.

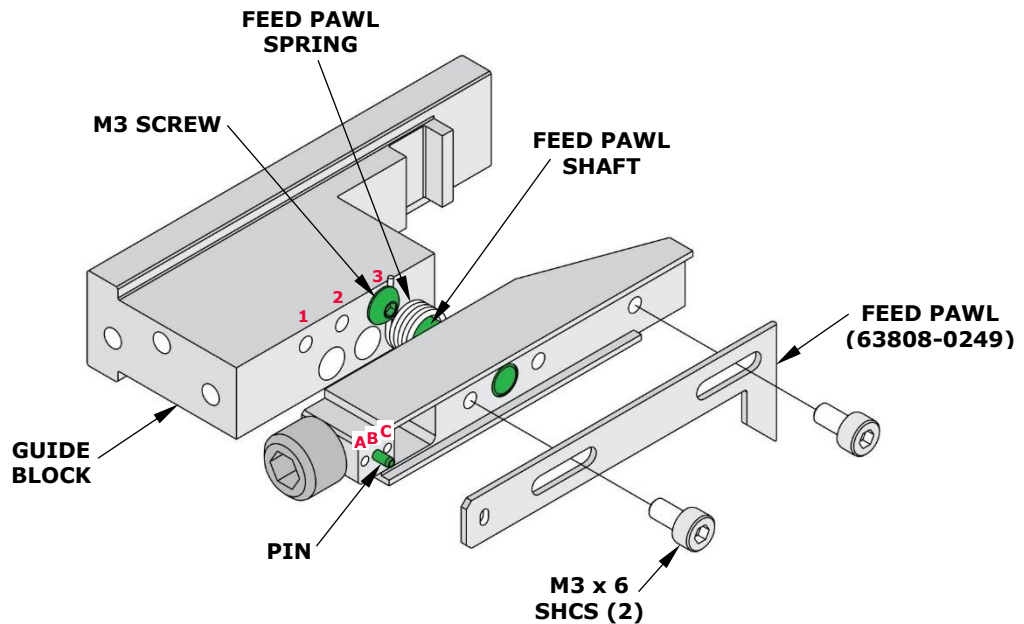

Figure 2

**Note:** Each applicator is configured and tested by Molex prior to shipping, and the above settings were used to produce the included sample crimps.

### Third Dial/Ram Assembly

○ Indicates item number on the Parts List and Assembly Drawing

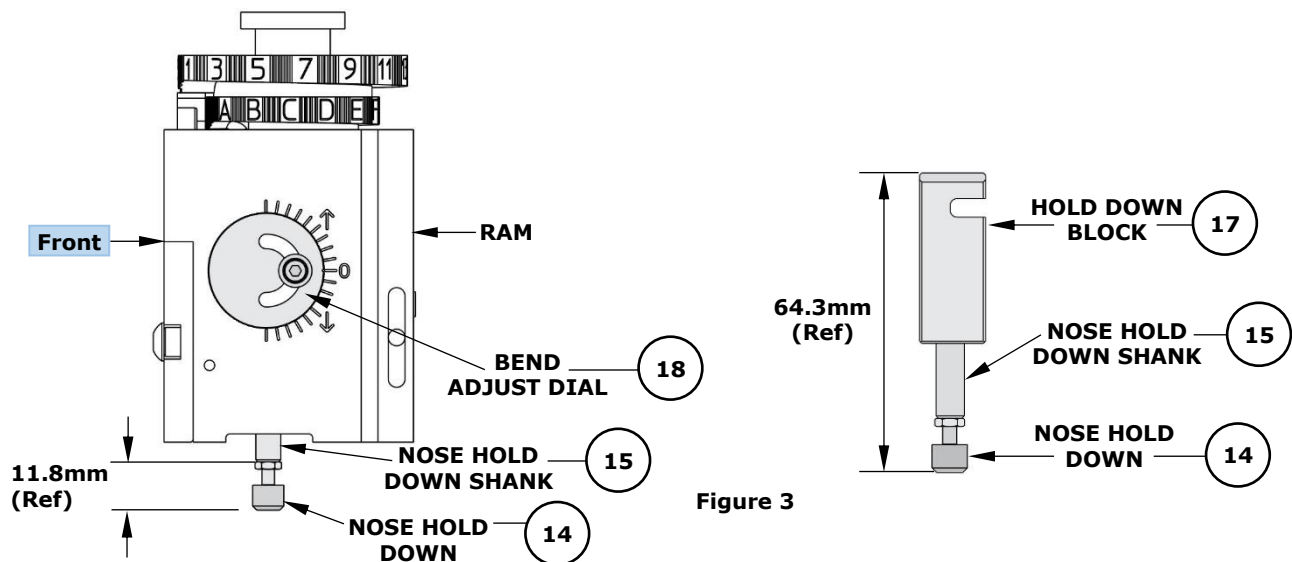

Figure 3

**Note:** The above dimensions were measured during setup and are included as a reference only. Additional adjustments may be required before crimping for production.

### Mounting Datum Location

This applicator was assembled and tested by Molex with the mounting datum in the location shown in Figure 4. Do not remove the mounting datum.

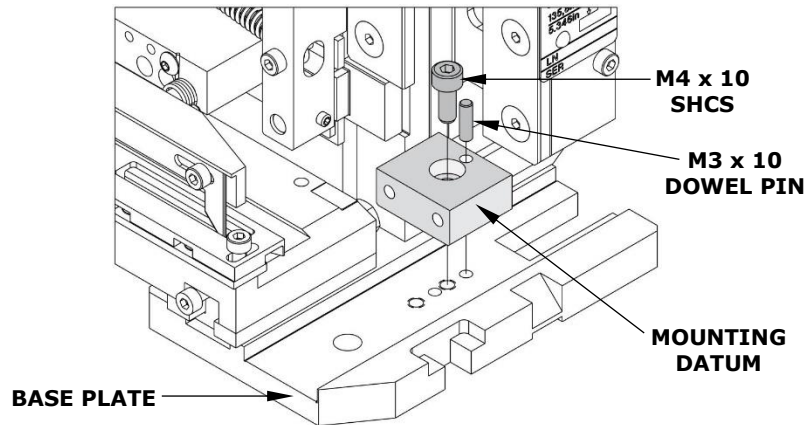

Figure 4

### PNEUMATIC CONNECTION (AIR FEED)

- The pneumatic feed applicator uses a double-acting air cylinder that must be actuated by a 4-way pneumatic valve.
- The air cylinder is equipped with push-in fittings for 6mm diameter vinyl or Nylon tube. Adapters are included for 1/4" diameter and 4mm diameter vinyl or Nylon tube.

**Note:** The TM-3000 and TM-4000 presses have pneumatic valves with 1/4" diameter tube fittings. Be sure to install the 1/4" diameter adapters in the air cylinder fittings and use 1/4" diameter vinyl or Nylon tube.

- Pneumatic tubes must be connected as shown in Figure 5. Tubes are typically connected so the terminal feed is forward when the applicator ram is up.
- When using the TM-3000 or TM-4000 presses, connect the tubes to the press pneumatic valve as shown in Figure 6.

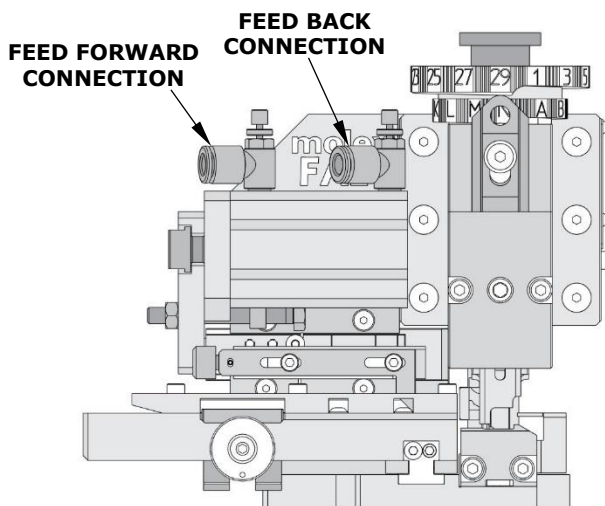

Figure 5

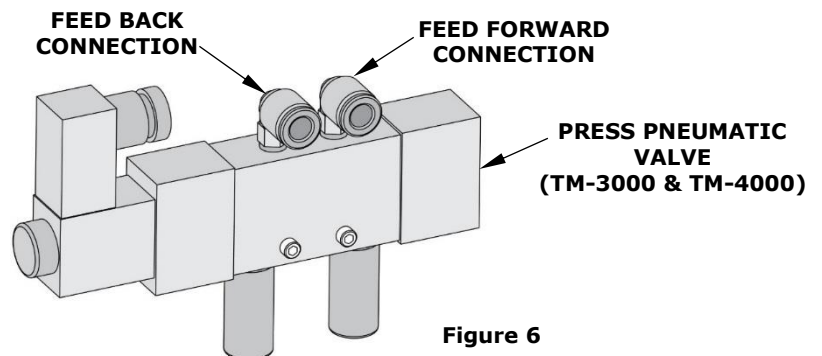

Figure 6

**Application Tooling Support**

**Phone:** (402) 458-TOOL (8665)

**E-Mail:** [toolingsupport@molex.com](mailto:toolingsupport@molex.com)

**Website:** [www.molex.com/applicationtooling](http://www.molex.com/applicationtooling)

Molex is a registered trademark of Molex, LLC in the United States of America and may be registered in other countries; all other trademarks listed herein belong to their respective owners.