

25 WAY CONNECTOR ASSEMBLY  
KEY 1 & KEY 5

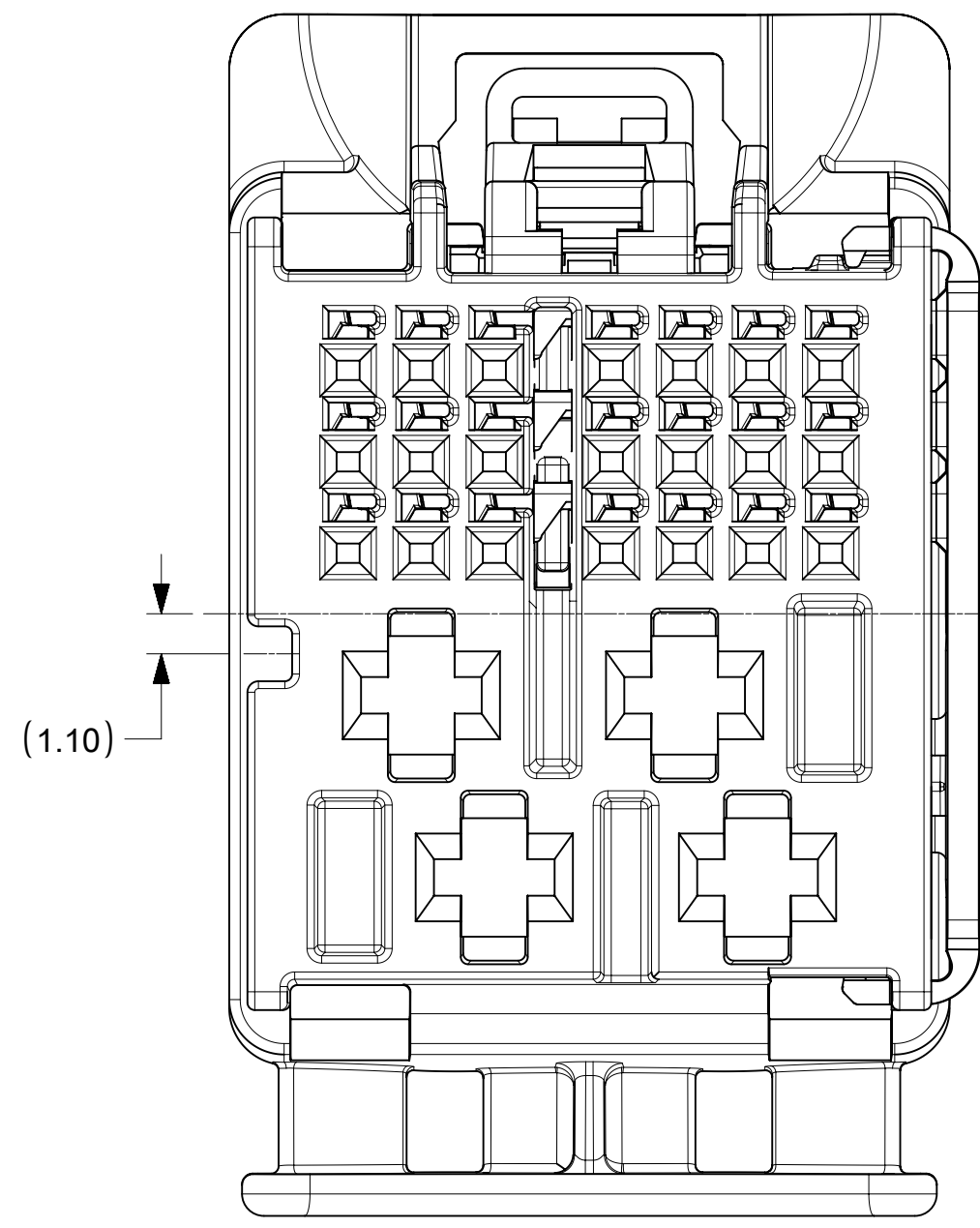

25 WAY CONNECTOR ASSEMBLY  
KEY 2 & KEY 6

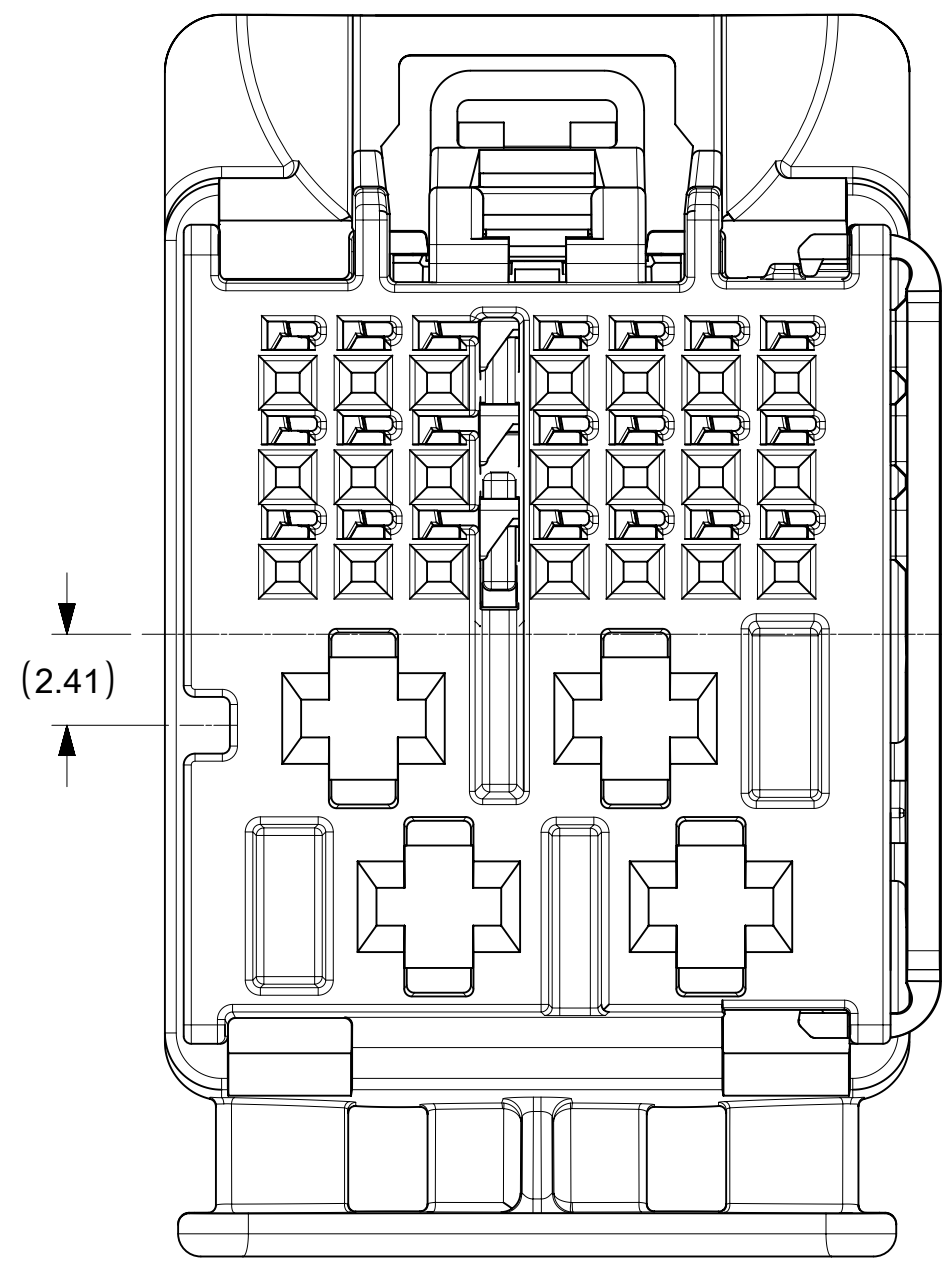

25 WAY CONNECTOR ASSEMBLY  
KEY 3 & KEY 7

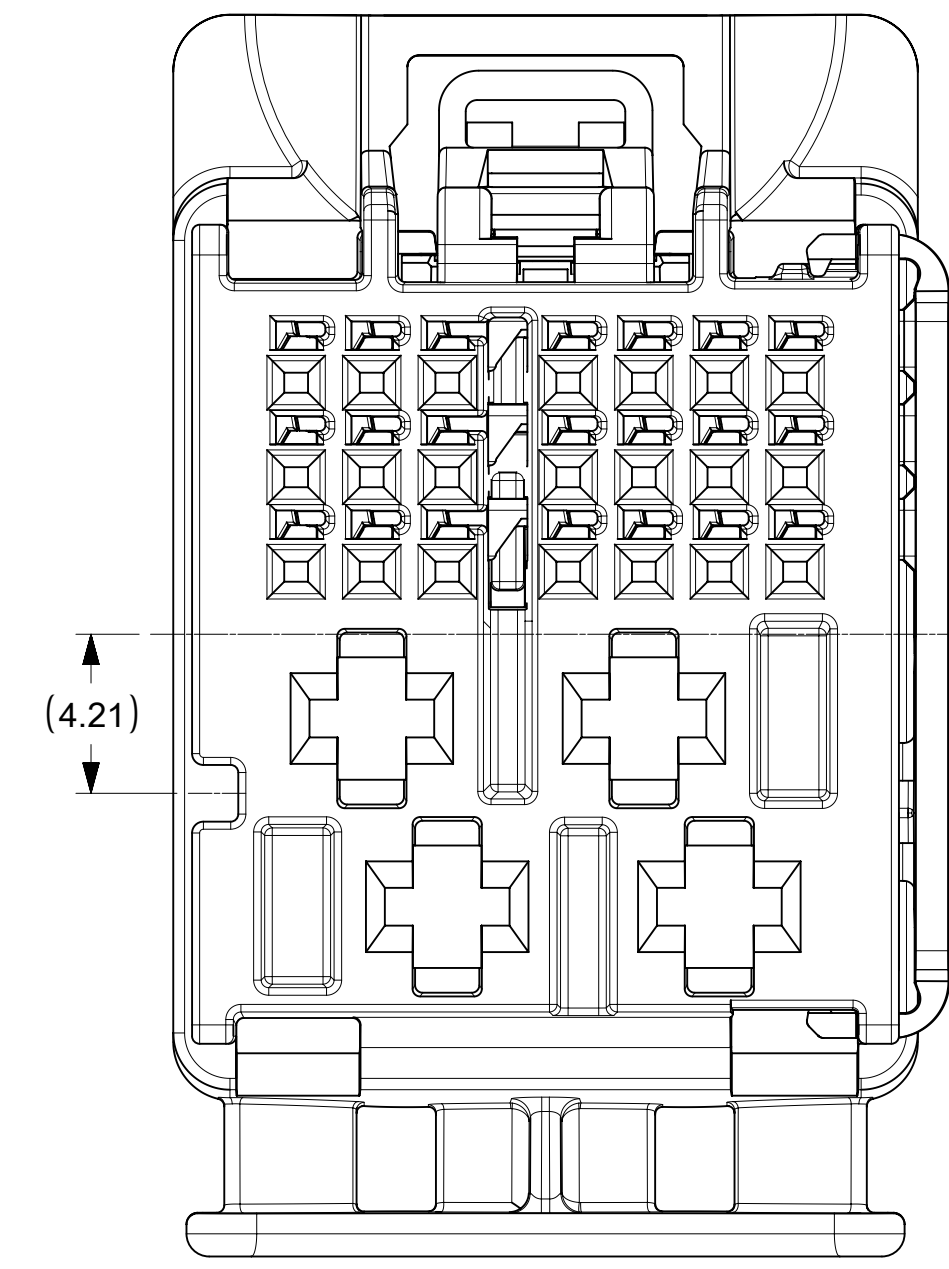

25 WAY CONNECTOR ASSEMBLY  
KEY 4 & KEY 8

NOTES: VALID UNLESS OTHERWISE SPECIFIED

1. GENERAL:
- a. APPLICATION SPECIFICATION SEE: AS-160014-001
  - b. PRODUCT SPECIFICATION SEE: PS-160014-001
  - c. PACKAGING SPECIFICATION PER MOLEX DRAWING: PK-31302-266
  - d. PARTS MUST BE IN COMPLIANCE TO MOLEX CHEMICAL SUBSTANCES FOR PRODUCTS AND PACKAGING SPECIFICATION: ES-40000-5016
  - e. DATA MUST BE SUBMITTED UNDER THE MOLEX PART NUMBER TO IMDS (COMPANY ID#13255)

2. DESIGN - MATERIALS:
- a. SEE BOM TABLE

3. DESIGN - GEOMETRY:
- a. ALL GRAPHIC DATA IS BASIC (NO TOLERANCE) AND MUST BE TAKEN FROM THE DATA FILE AT ITS LATEST REVISION.
  - b. PRODUCT DESIGN MODEL NUMBER(S): SEE BOM TABLE
  - c. GEOMETRIC DIMENSIONS AND TOLERANCES PER ASME Y14.5-2009
  - d. EDGES AND UNDIMENSIONED DETAILS PER ISO13715
  - e. CORNERS SHOWN AS SHARP TO BE R 0.2 MAX.
  - f. MARKED TEXT TO INCLUDE RECYCLING CODE, CAVITY ID, VENDOR IDENTIFICATION AND CUSTOMER MATERIAL NUMBER.
    - 1. LASER ETCHED DATE CODE
    - 1ST THROUGH 2ND DIGIT = CALENDAR YEAR
    - 3RD THROUGH 5TH DIGIT = "DAY #" OF YEAR
    - 6TH THROUGH 7TH DIGIT = HOUR OF DAY
    - 8TH THROUGH 9TH DIGIT = MINUTE OF HOUR
    - 10TH THROUGH 11TH DIGIT = SECOND OF MINUTE

4. DESIGN - MANUFACTURING:
- a. VISUAL DEFECTS SHALL MEET COSMETIC STANDARD PS-45499-002 (Class B)

PART NUMBER	PLATING	SUPPLIER	WIRE GAGE (mm2)	TERMINAL FAMILY	WIRE SPECIFICATION
200096-0101	TIN PLATING	MOLEX	0.35	TAK FAMILY (0.5 mm)	VW 60306 OR GMW 15626 (SEE APPLICATION SPECIFICATION FOR MORE DETAILS)
200096-0201	TIN PLATING	MOLEX	0.13	TAK FAMILY (0.5 mm)	
2272196-2	TIN PLATING	TE	0.35	Generation 50 Locking Lance (0.5mm)	SAE/ J1128 THIN WALL INSULATION
2272196-1	TIN PLATING	TE	0.13	Generation 50 Locking Lance (0.5mm)	
1-968851-1	TIN PLATING	TE	1.0 - 2.5	AMP MCP 2.8	GMW 15626 INSULATION TYPE FLR (REGULAR THIN WALL)
1-968849-1	TIN PLATING	TE	0.5 - 1.0	AMP MCP 2.8	
15457849	TIN PLATING	DELPHI	1.5 - 2.5	CTS 2.8mm	
15457848	TIN PLATING	DELPHI	0.5 - 1.0	CTS 2.8mm	

ITEM	DESCRIPTION	COLOR	RECYCLING CODE	WEIGHT (GRAMS)	RIB OPTION	NO OF ITEMS REQUIRED												
1	OUTER SHROUD - KEY 1	LIGHT GREEN B	SPS/PA66-GF20	4.1	A	1												
2	OUTER SHROUD - KEY 2	STONE GRAY	SPS/PA66-GF20	4.1	A		1											
3	OUTER SHROUD - KEY 3	BLACK	SPS/PA66-GF20	4.1	A			1										
4	OUTER SHROUD - KEY 4	DARK GRAY	SPS/PA66-GF20	4.1	A				1									
5	OUTER SHROUD - KEY 5	DK PURPLE A	SPS/PA66-GF20	4.1	B					1								
6	OUTER SHROUD - KEY 6	TBD	SPS/PA66-GF20	4.1	B						1							
7	OUTER SHROUD - KEY 7	TBD	SPS/PA66-GF20	4.1	B							1						
8	OUTER SHROUD - KEY 8	LT GRAY	SPS/PA66-GF20	4.1	B								1					
9	ISL	NATURAL	SPS-GF30	0.37	N/A	1	1	1	1	1	1	1	1	1	1	1	1	1
10	CPA	NATURAL	PA66-GF50	0.08	N/A	1	1	1	1	1	1	1	1	1	1	1	1	1
11	INNER HOUSING	STONE GRAY	SPS/PA66-GF20	1.04	N/A	1	1	1	1									
12	INNER HOUSING	STONE GRAY	SPS/PA66-GF20	1.04	N/A							1	1	1	1	1	1	1

MOLEX ASSEMBLY PART NO.'S	
1600270011	KEY 1
1600270012	KEY 2
1600270013	KEY 3
1600270014	KEY 4
1600270015	KEY 5
1600270016	KEY 6
1600270017	KEY 7
1600270018	KEY 8

RIB OPTION A

RIB OPTION B

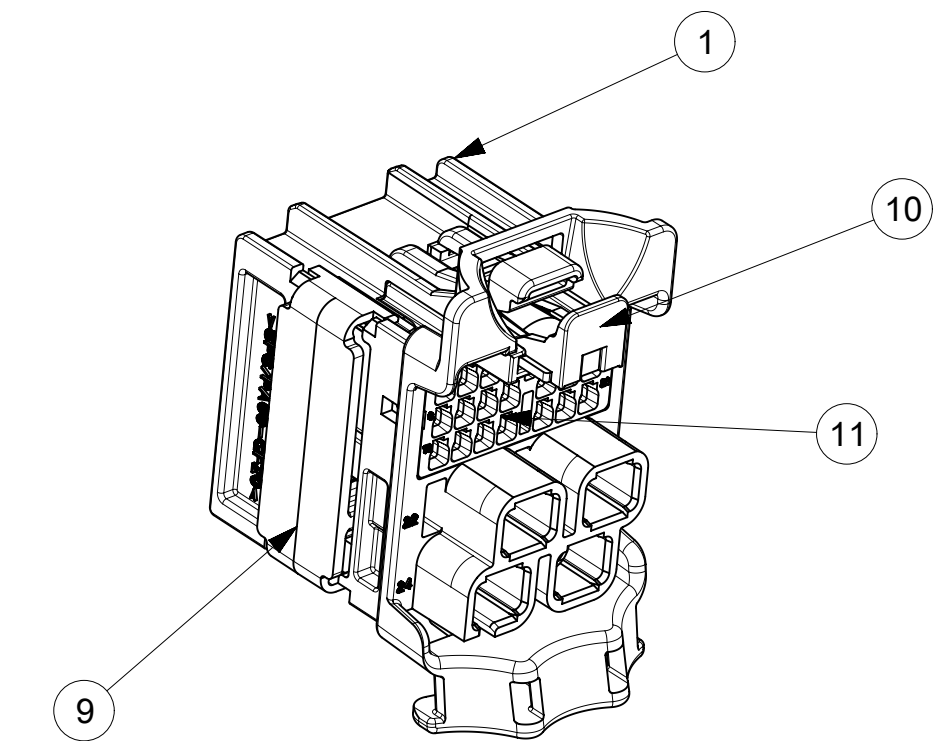
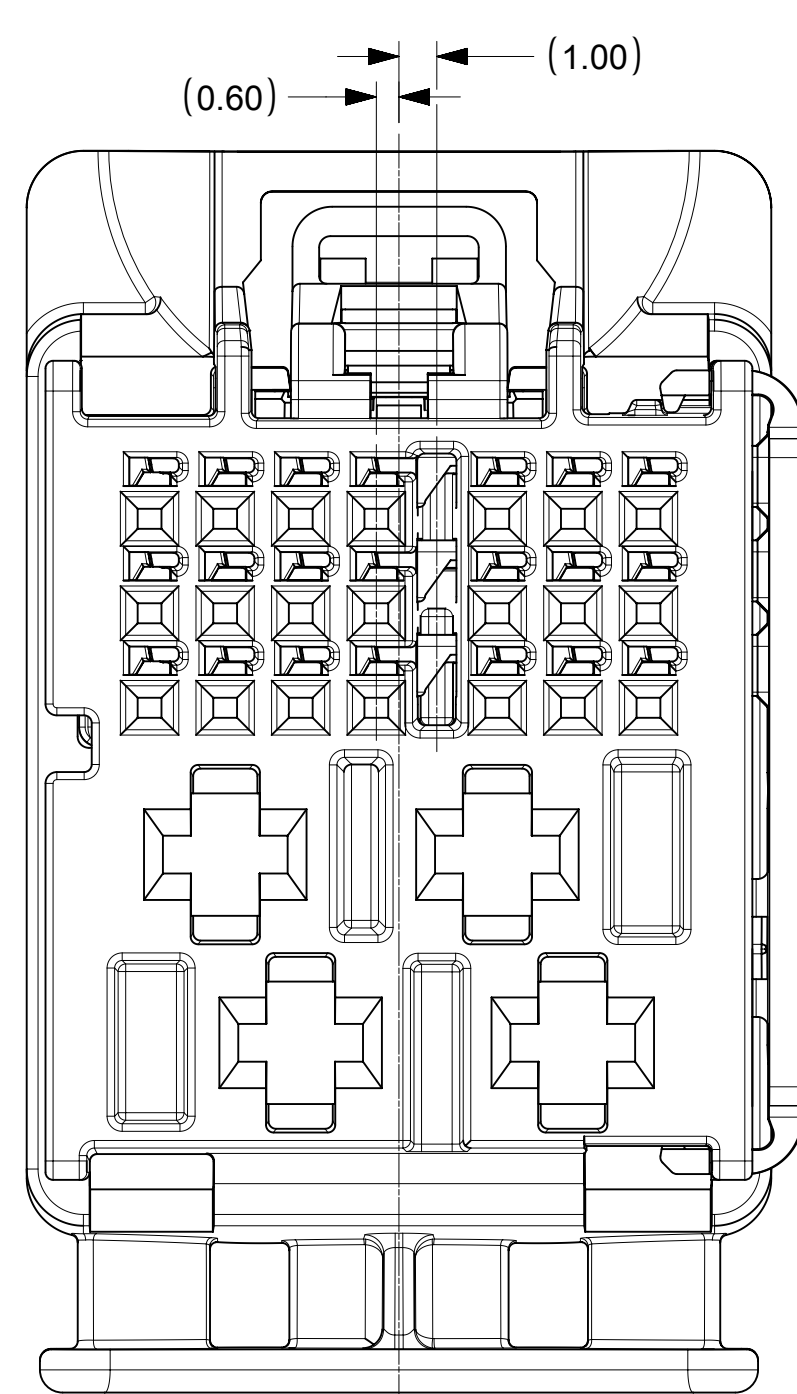
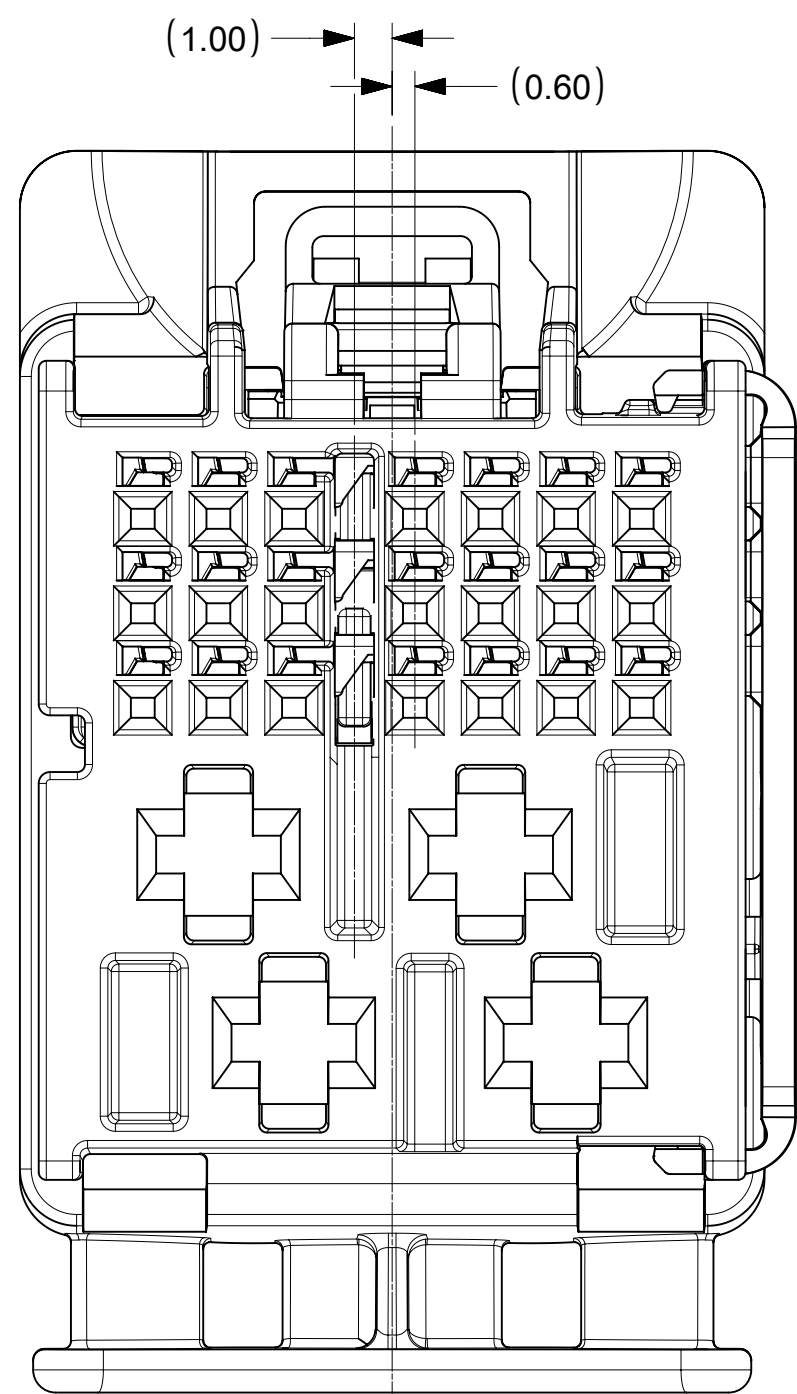

SCALE 2:1

<b>SYMBOLS</b> DIMENSION UNITS: mm SCALE: 5:1 GENERAL TOLERANCES (UNLESS SPECIFIED): ANGULAR TOL ± 3.0° 4 PLACES ± 3 PLACES ± 2 PLACES ± 0.3 1 PLACE ± 0.3 0 PLACES ± 0.3 DRAFT WHERE APPLICABLE MUST REMAIN WITHIN DIMENSIONS	THIS DRAWING CONTAINS INFORMATION THAT IS PROPRIETARY TO MOLEX ELECTRONIC TECHNOLOGIES, LLC AND SHOULD NOT BE USED WITHOUT WRITTEN PERMISSION CURRENT REV DESC: UPDATED 2.8 CAVITY VIEWS ON SHEET 2		<b>molex</b> 25WAY STAK50H HYBRID ASSEMBLY CONNECTOR ASSEMBLY PRODUCT CUSTOMER DRAWING	
	EC NO: 613462 DRWN: RCARLSON 2019/03/07 CHK'D: JCONDON 2019/03/08 APPR: JCONDON 2019/03/08		INITIAL REVISION: DRWN: RCARLSON 2019/02/18 APPR: JCONDON 2019/02/25	
DOCUMENT NUMBER: 1600270011 DOC TYPE: PSD DOC PART: 000 REVISION: A2		MATERIAL NUMBER: SEE CHART CUSTOMER: GENERAL MARKET SHEET NUMBER: 1 OF 2		

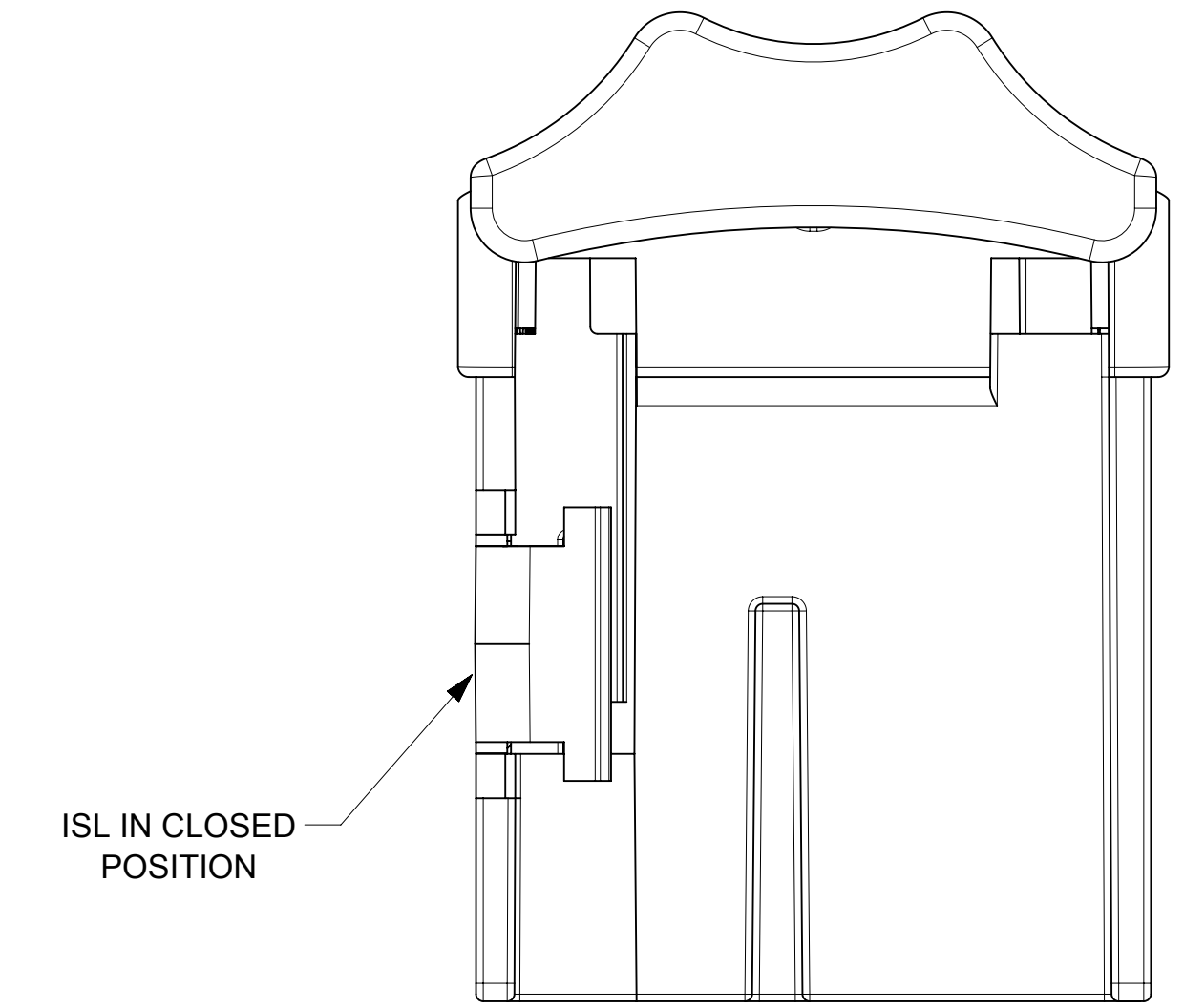
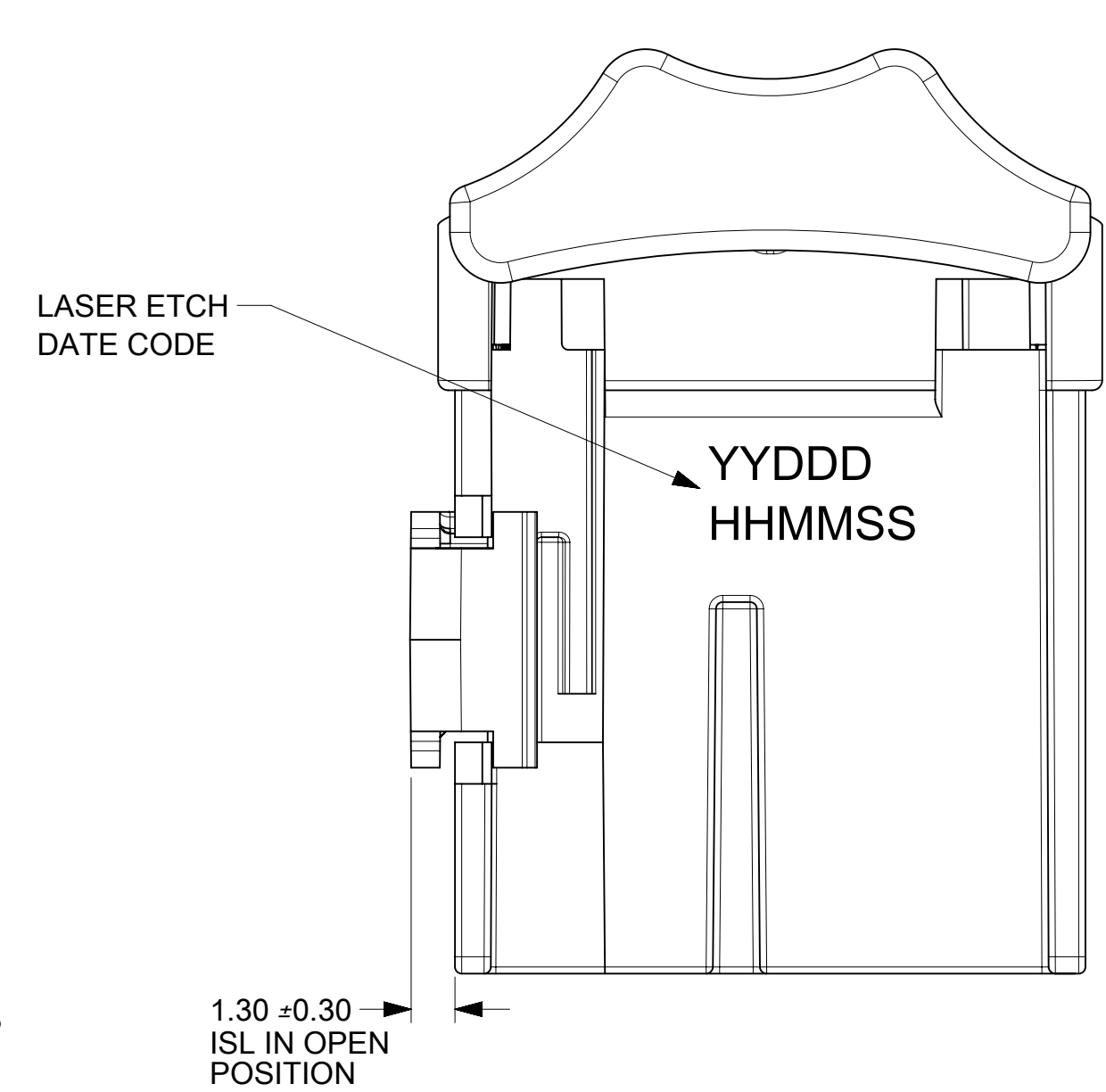
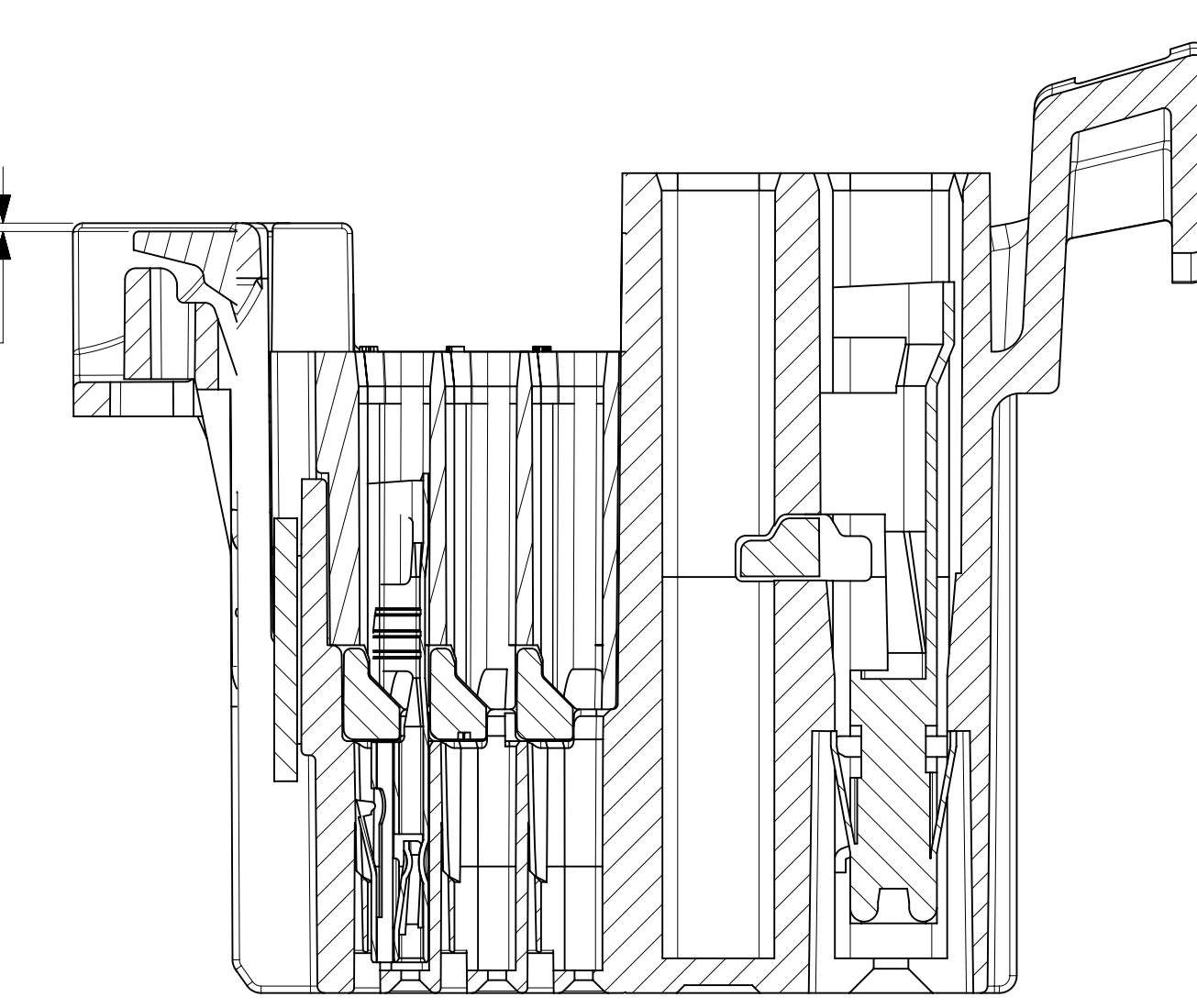
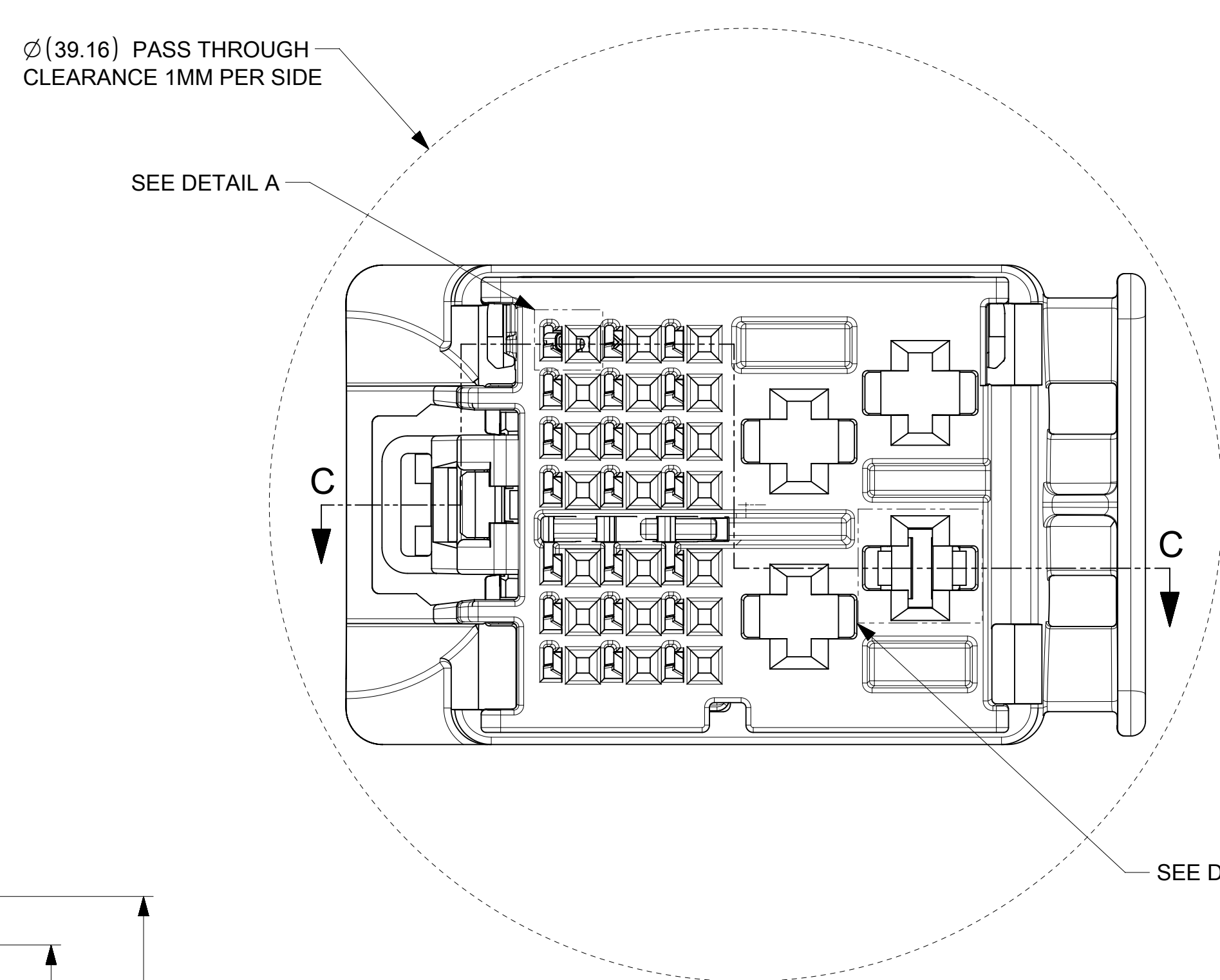
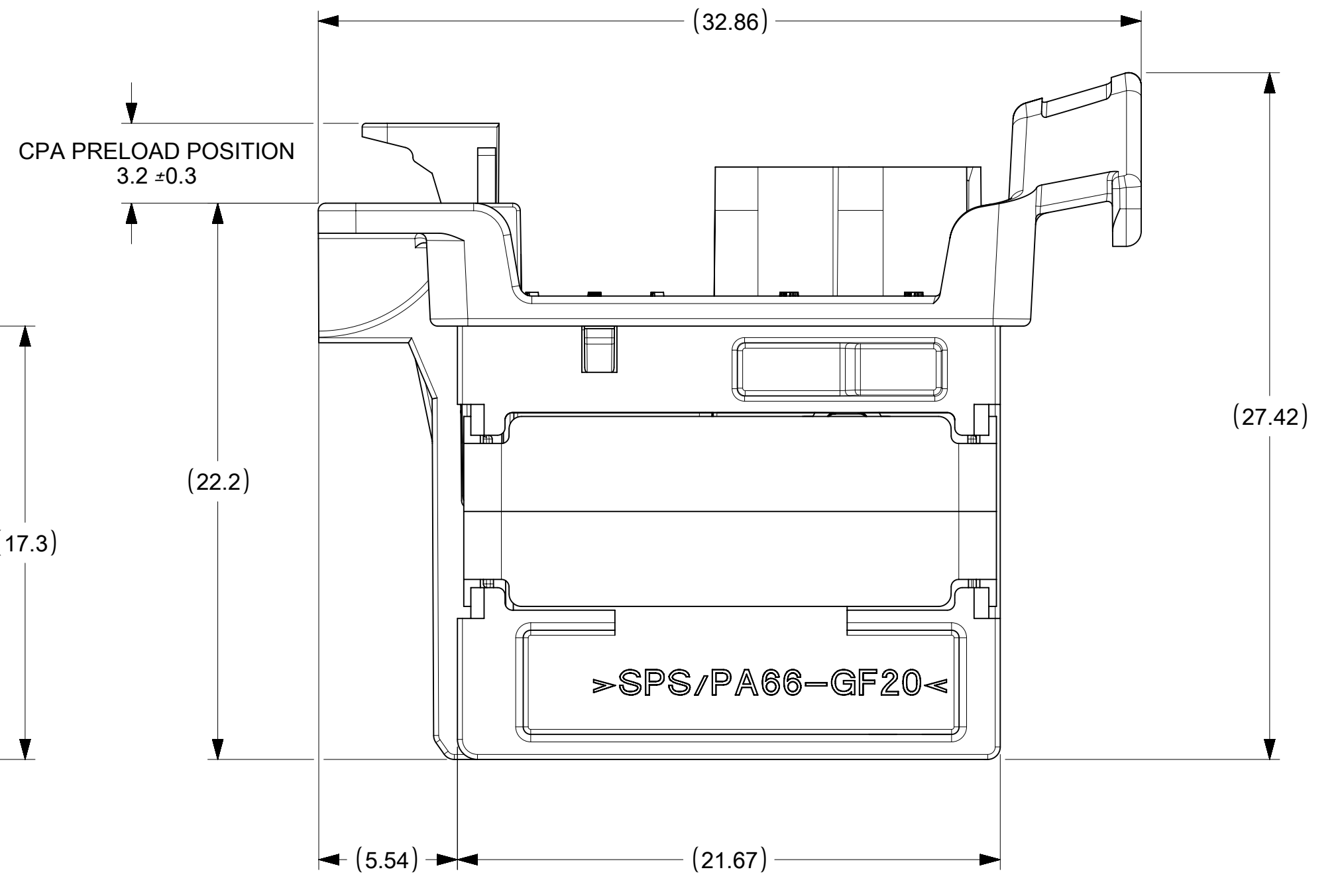
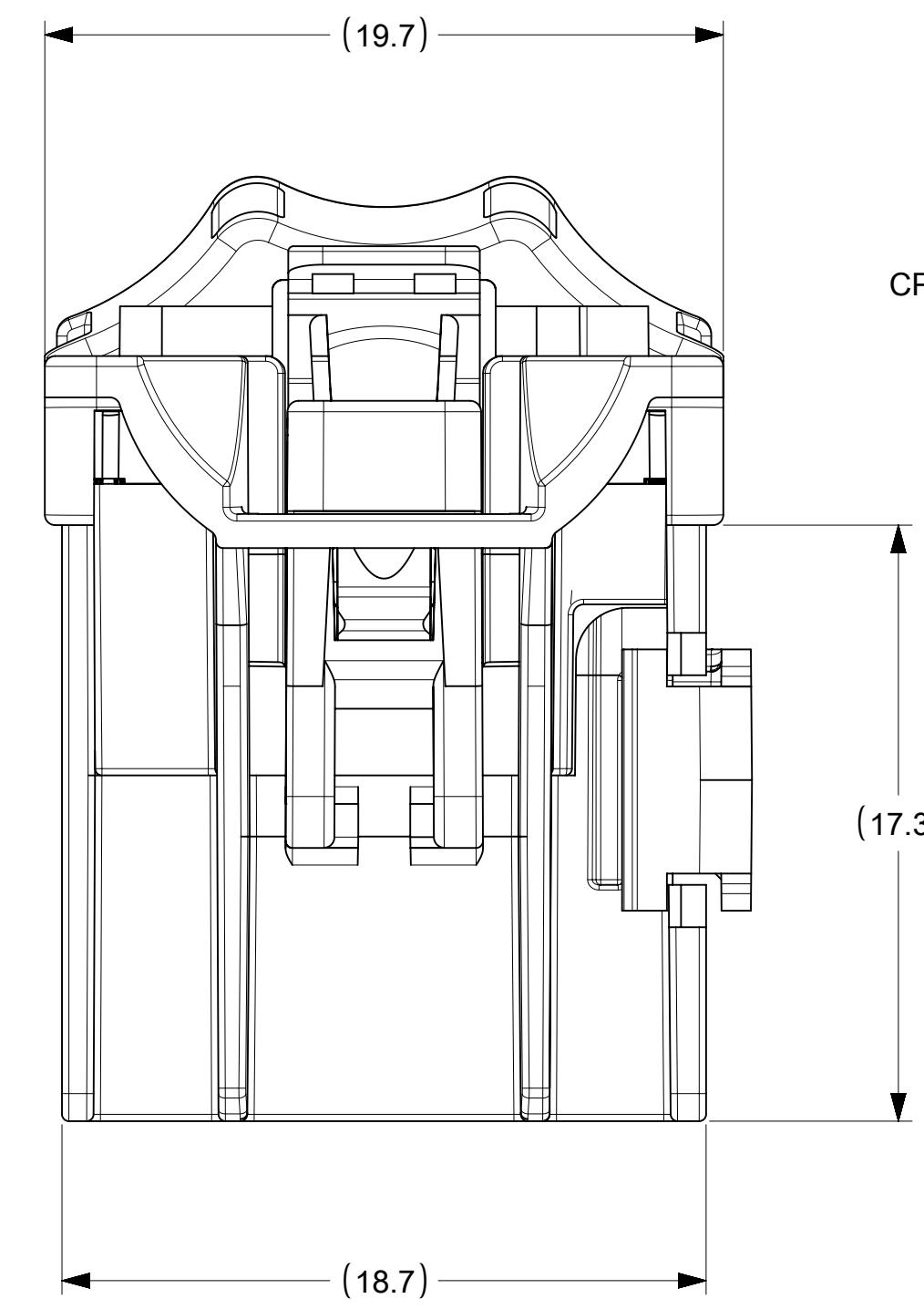
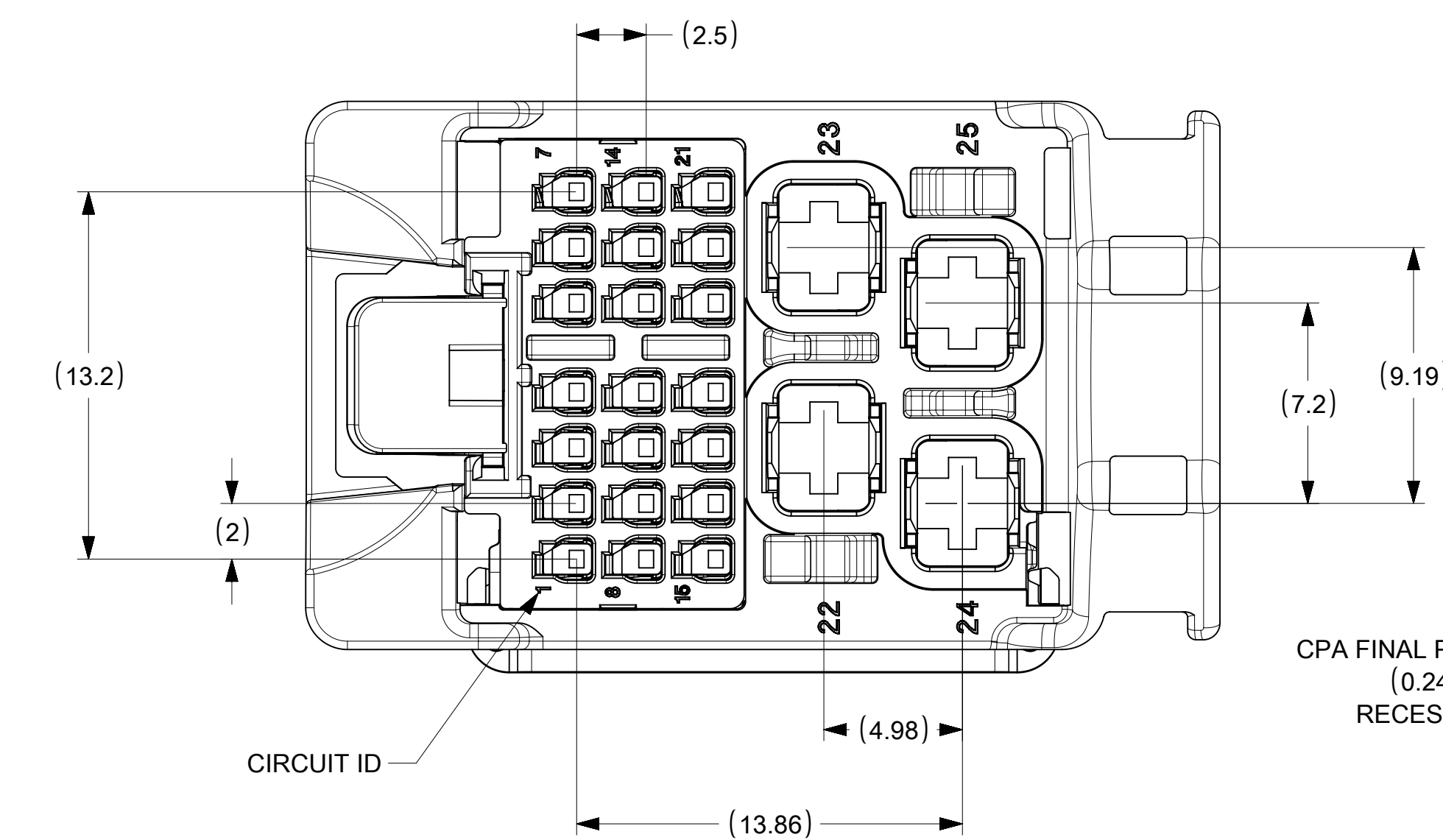
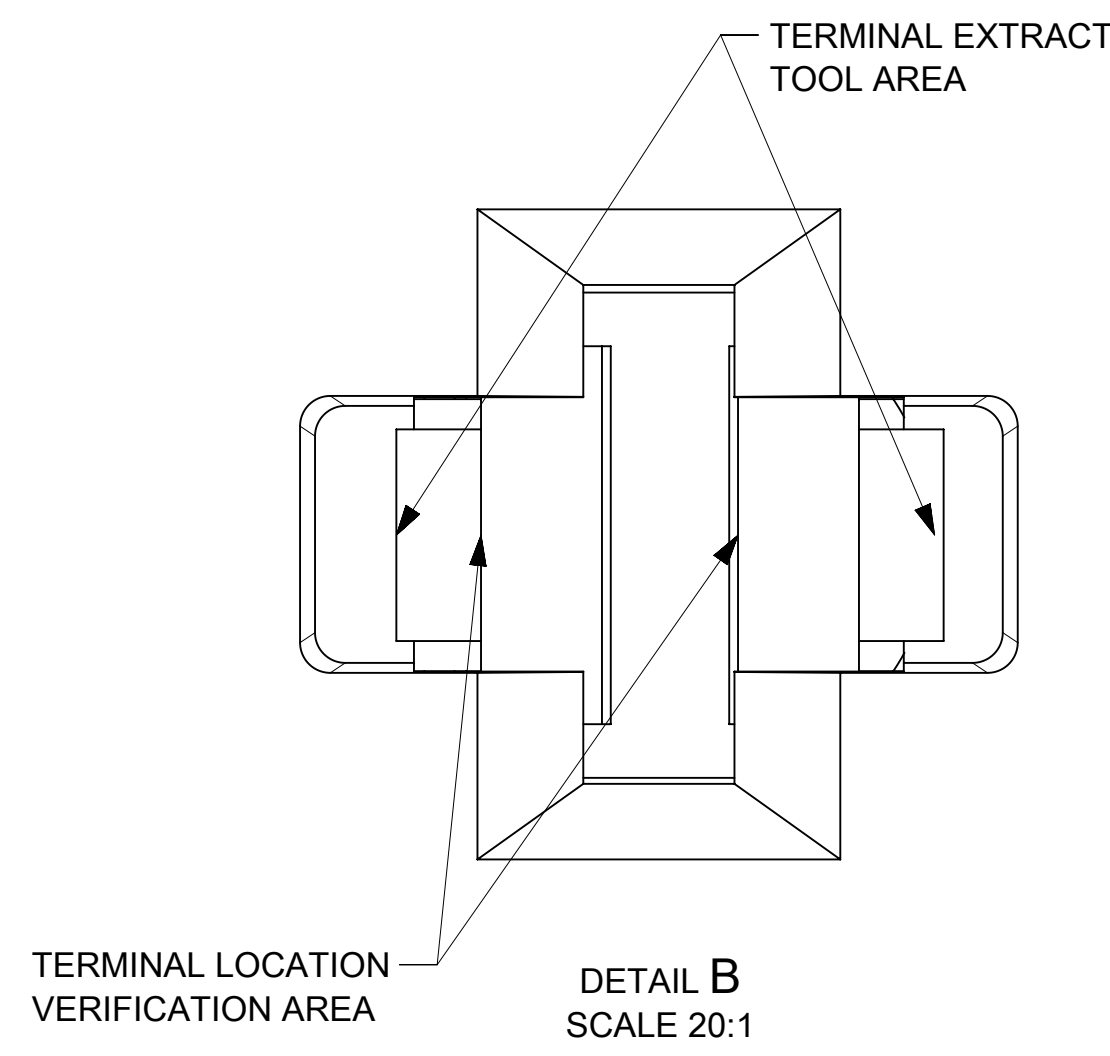
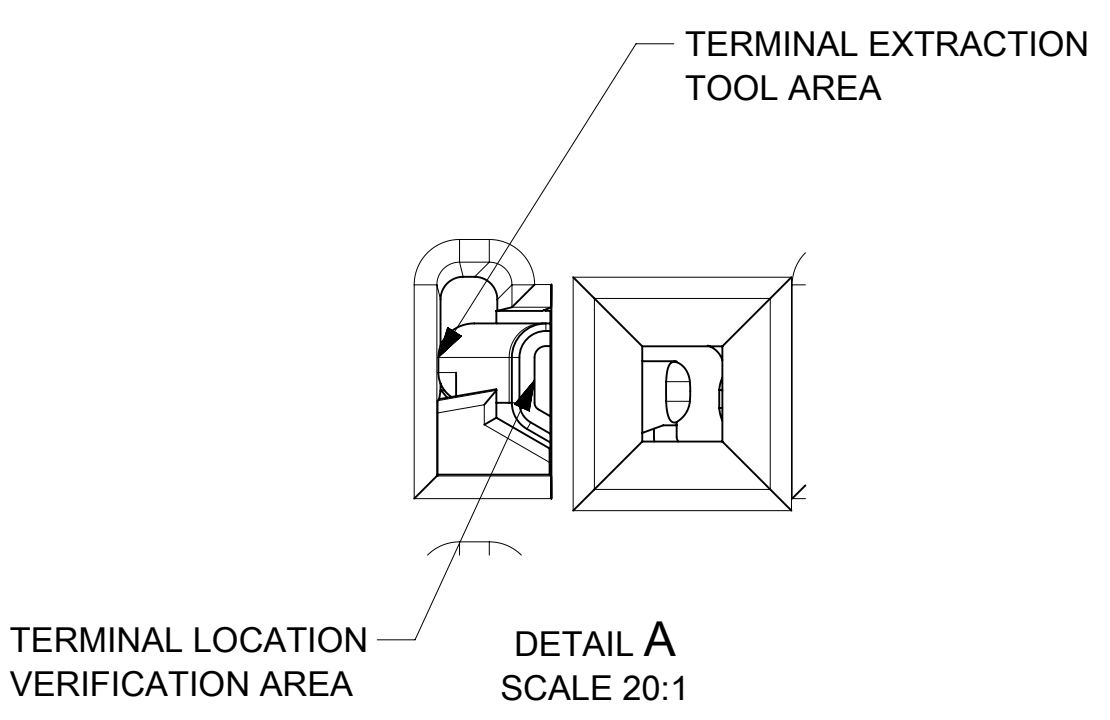

SYMBOLS	THIS DRAWING CONTAINS INFORMATION THAT IS PROPRIETARY TO MOLEX ELECTRONIC TECHNOLOGIES, LLC AND SHOULD NOT BE USED WITHOUT WRITTEN PERMISSION	
	DIMENSION UNITS	SCALE
▽ = 0	mm	5:1
▽ = 0	GENERAL TOLERANCES (UNLESS SPECIFIED)	
▽ = 0	ANGULAR TOL	± 3.0°
▽ = 0	4 PLACES	±
▽ = 0	3 PLACES	±
▽ = 0	2 PLACES	± 0.3
▽ = 0	1 PLACE	± 0.3
▽ = 0	0 PLACES	± 0.3
■ = 0	DRAFT WHERE APPLICABLE MUST REMAIN WITHIN DIMENSIONS	
▽ = 0	THIRD ANGLE PROJECTION	
CURRENT REV DESC: UPDATED 2.8 CAVITY VIEWS ON SHEET 2		
EC NO: 613462		
DRWN: RCARLSON		2019/03/07
CHK'D: JCONDON		2019/03/08
APPR: JCONDON		2019/03/08
INITIAL REVISION:		
DRWN: RCARLSON		2019/02/18
APPR: JCONDON		2019/02/25
DRAFTING		SERIES
D-SIZE		160027
MATERIAL NUMBER		CUSTOMER
SEE SHEET 1		GENERAL MARKET
DOCUMENT NUMBER		DOC TYPE   DOC PART   REVISION
1600270011		PSD   000   A2
SHEET NUMBER		
2 OF 2		

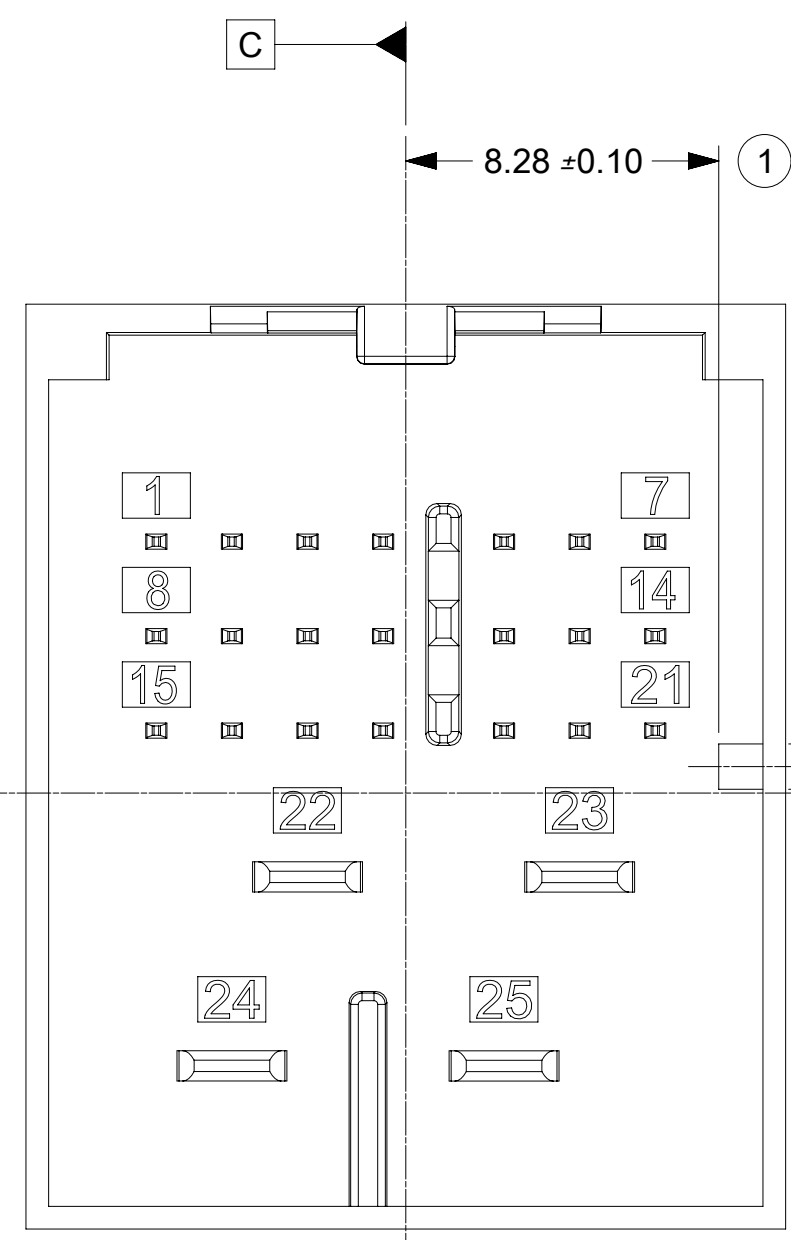

INTERFACE KEY 1 & KEY 5

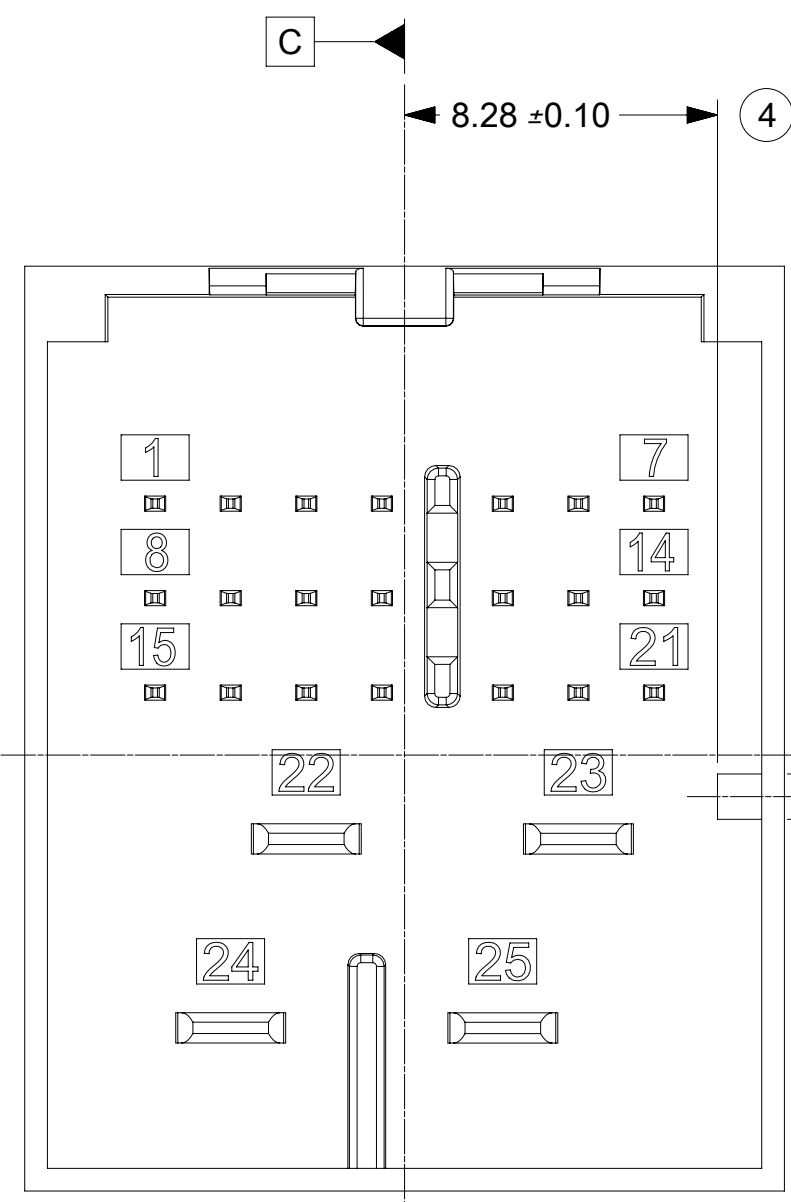

INTERFACE KEY 2 & KEY 6

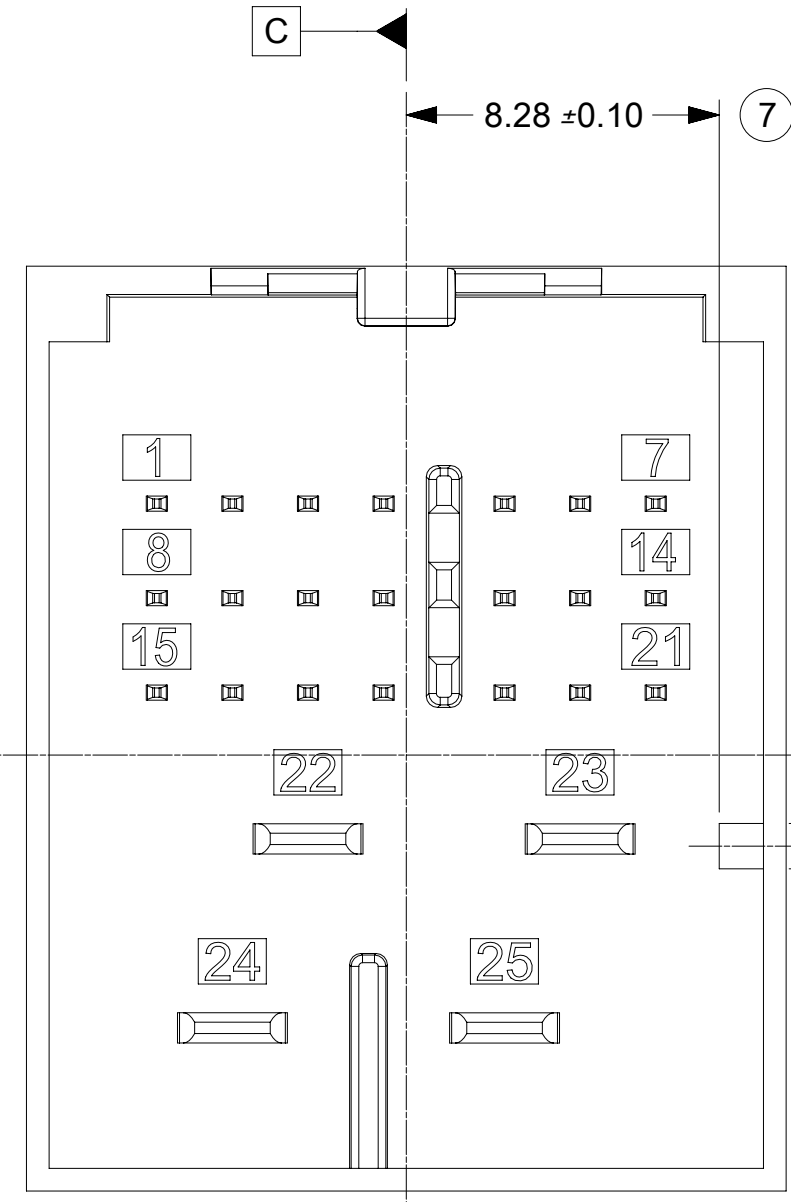

INTERFACE KEY 3 & KEY 7

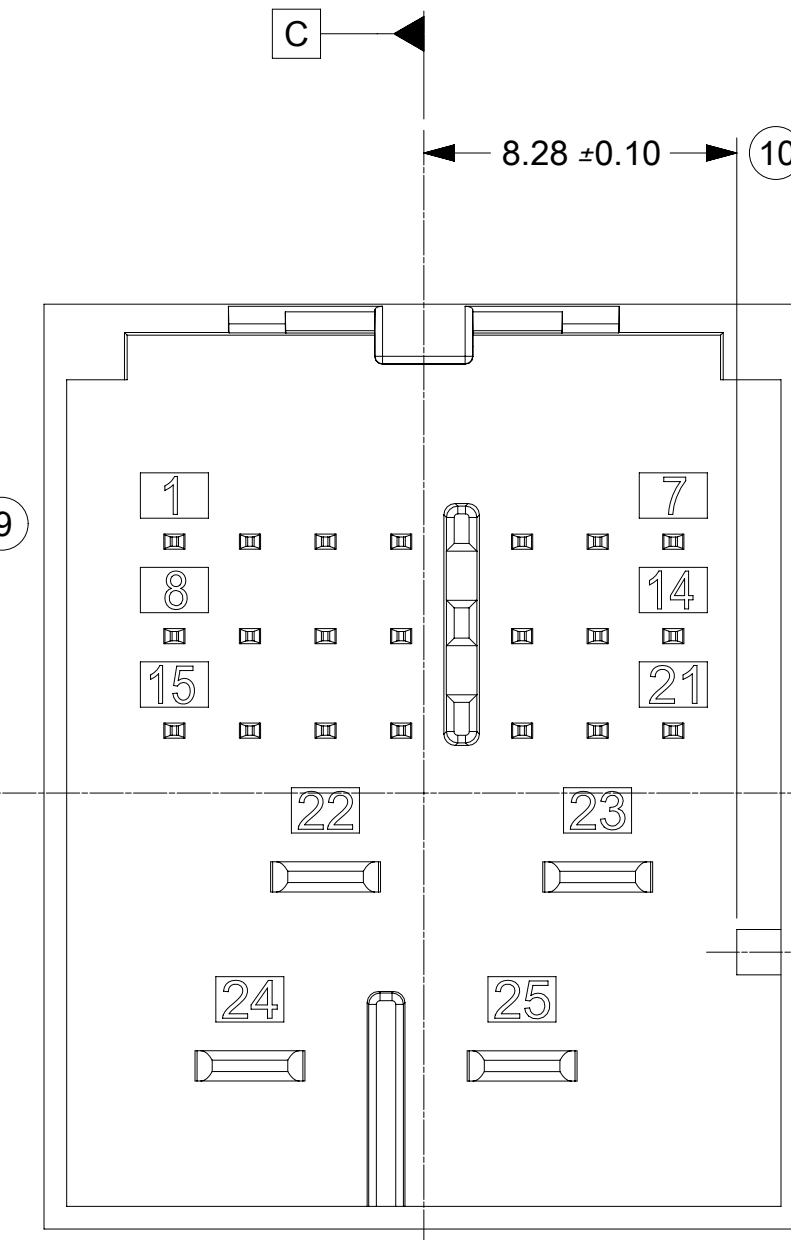

INTERFACE KEY 4 & KEY 8

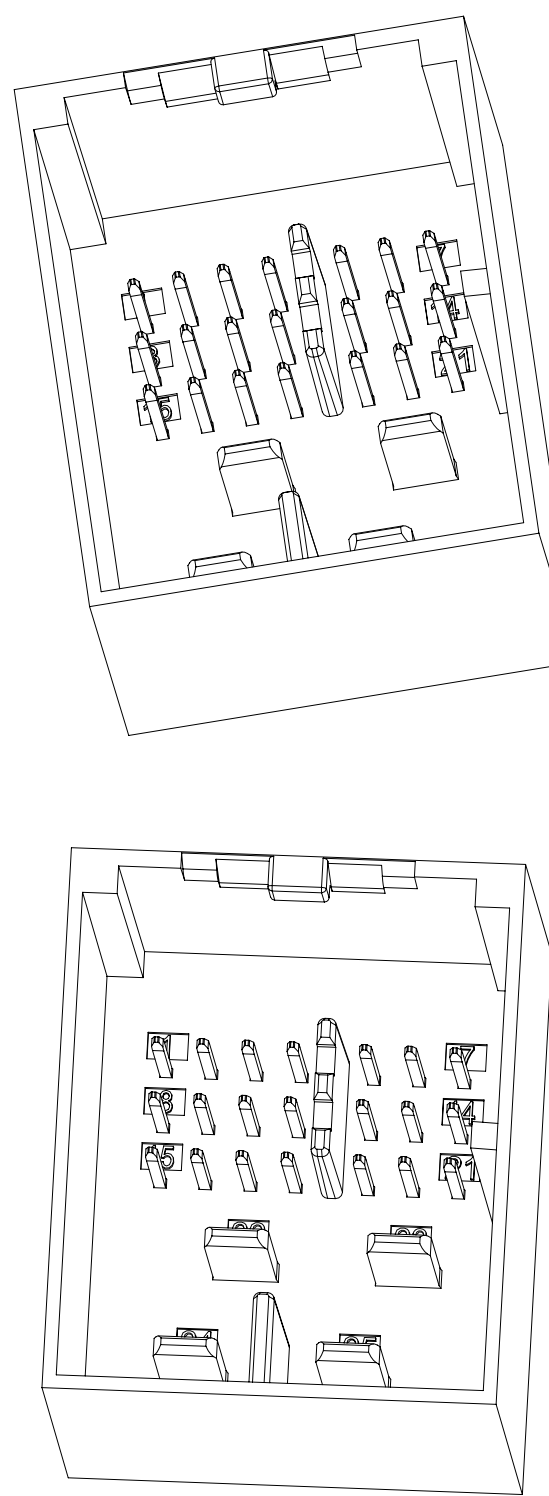

INTERFACE OPTIONS		
KEY	RIB OPTION	MATING CONNECTOR COLOR
1	OPTION A	LIGHT GREEN B
2	OPTION A	STONE GRAY
3	OPTION A	BLACK
4	OPTION A	DARK GRAY
5	OPTION B	DARK PURPLE A
6	OPTION B	TBD
7	OPTION B	TBD
8	OPTION B	LIGHT GRAY

NOTES: VALID UNLESS OTHERWISE SPECIFIED

1. DESIGN - MATERIALS:

- a. RESIN MATERIAL : PBT+GF30 OR SPS+GF30 OR EQUIVALENT
- b. PIN/BLADE MATERIAL : ACCORDING TO USCAR DRAWING EWCAP-001 NOTE B2
- c. PLATING: ACCORDING TO USCAR DRAWING EWCAP-001 TIN REFLOW WITH UNDERPLATE
- d. PIN TIPS ACCORDING TO USCAR DRAWING EWCAP-001 (050-T001 & 280-T001)
- e. DEVIATION TO EWCAP-001 ACCEPTABLE IF PERFORMANCE (ELECTRICAL/MECHANICAL) IS SHOWN TO BE EQUAL OR BETTER AS REQUIRED BY VALIDATION TESTING.
- Ⓢ 1. DEVIATION TO TIN PLATING THICKNESS AS NECESSARY TO MEET MATING FORCE AND ALL VALIDATION REQUIREMENTS

2. DRAWING - GEOMETRY:

- a. ALL GRAPHIC DATA IS BASIC (NO TOLERANCE) AND MUST BE TAKEN FROM THE DATA FILE AT ITS LATEST REVISION.
- b. GEOMETRIC DIMENSIONS AND TOLERANCES PER ASME Y14.5M-2009.
- c. GENERAL TOLERANCES:  
 LINEAR : PER DIN 16901 LINEAR CODE B FOR PRECISION ENGINEERING  
 ANGULAR : ±3°
- d. EDGES AND UNDIMENSIONED DETAILS PER ISO13715
- e. CORNERS SHOW AS SHARP TO BE R 0.2 MAX.
- f. LETTERS SHALL BE 0.2 MAX RAISED IN 0.25 MAX RECESSED PAD.  
 THIS INCLUDES RECYCLING CODE, CAVITY ID, VENDOR IDENTIFICATION, AND CUSTOMER MATERIAL NUMBER.

3. DESIGN - MANUFACTURING:

- a. DRAFT TO BE WITHIN TOLERANCE.

INSPECTION BALLOON NUMBER LOG	
PER DRAWING REVISION:	C1
LAST BALLOON NUMBER:	63
ADDED BALLOON NUMBER:	NONE
DELETED BALLOON NUMBER:	NONE

C1	UPDATED BASIC DIMENSIONS IN SECTION B-B ON SHEET 2 ECN: 649575 11/19/2020 YPENG47
C	ADDED 2.8MM BLADE LENGTH VARIANT FOR MATE FORCE REQUIREMENT ADDED NOTE 1.E.1 CHANGE RECORD: 626144 JPATE 10/22/2019
B1	ADDED BALLOONS JCONDON 08/02/2018
B	REMOVED 0.2MM FROM CONNECTOR LOCK TAB FEATURE
A2	ADDED CIRCUIT IDs
A1	ADDED NOTE 1e, MKOWALSKY 7/7/2017
8	GEOMETRY UPDATED , SPEMMARAJU 02/18/2016
7	UAU2016-1146 SAP # 10681629 JCONDON 03/25/2015

RIB OPTION A

RIB OPTION B

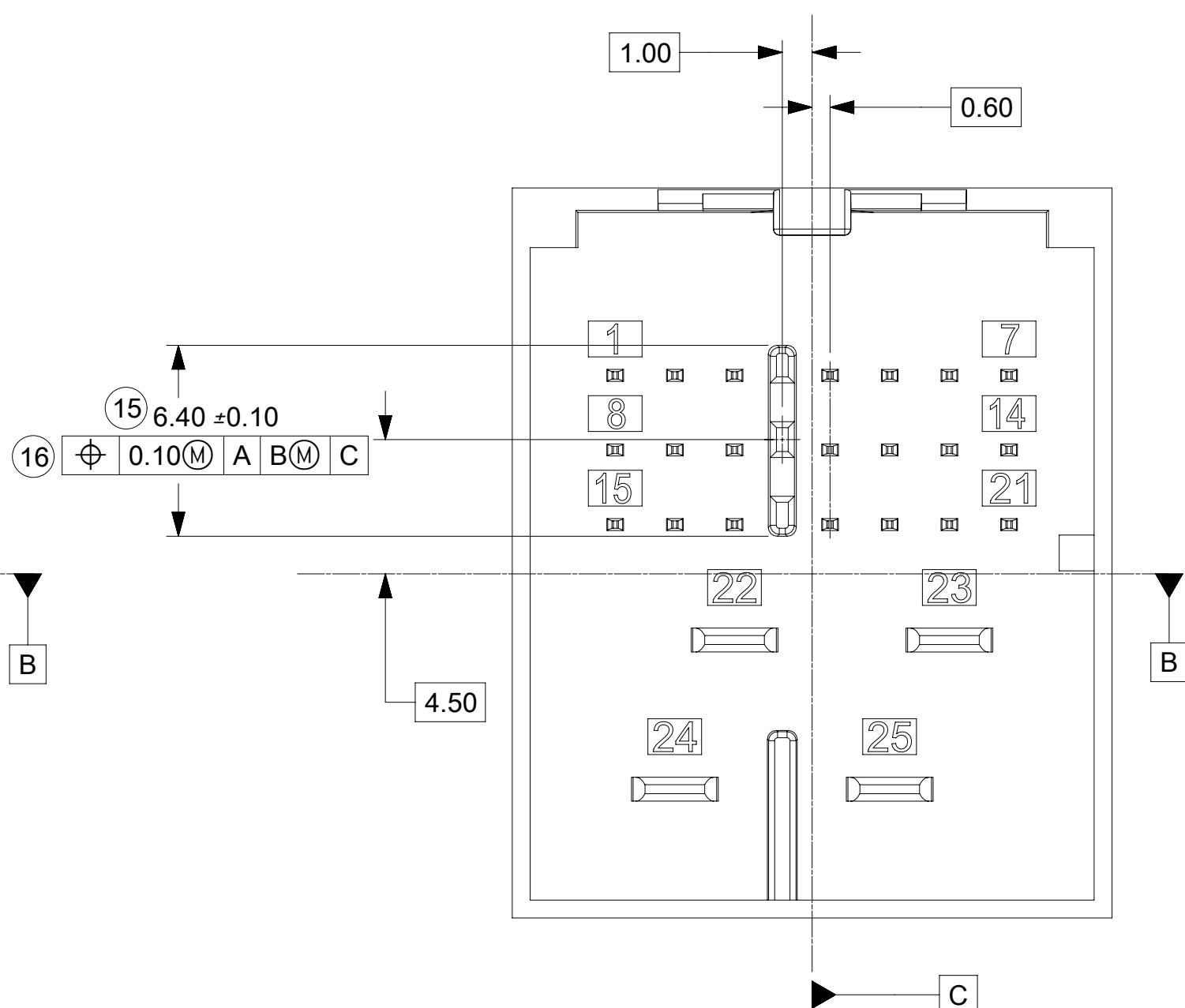
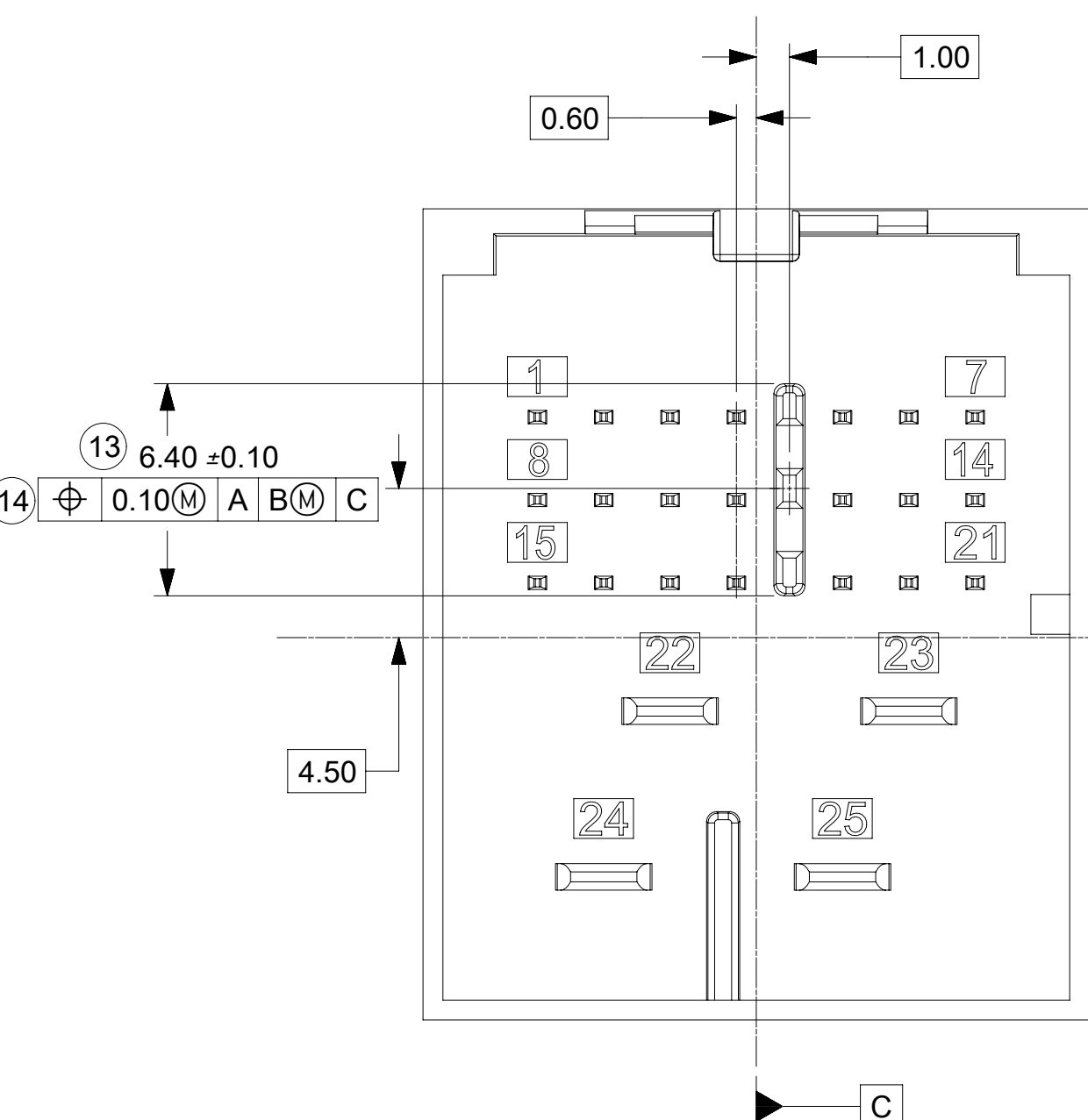

FUNCTIONAL SYMBOLS	DIMENSION UNITS	SCALE	CURRENT REV DESC: UPDATED BASIC DIMENSIONS IN SECTION B-B ON SHEET 2		
FA = 0	mm	5:1	EC NO: 649575 DRWN: YPENG47 2020/11/19 CHK'D: JRUTTER 2020/11/23 APPR: MVANSLAMBROU 2020/11/25 INITIAL REVISION: DRWN: SPEMMARAJU 2015/11/03 APPR: KDEKOSKI 2016/03/24		
FE = 0	GENERAL TOLERANCES (UNLESS SPECIFIED)				
FP = 0	ANGULAR TOL ± °				
DIVISIONAL SYMBOLS		4 PLACES ±			
		3 PLACES ±	DOCUMENT NUMBER: <b>SD-160027-002</b> DOC TYPE: PSD DOC PART: 000 REVISION: <b>C1</b>		
		2 PLACES ±			
		1 PLACE ±			
		0 PLACES ±	MATERIAL NUMBER: <b>160027</b> CUSTOMER: <b>GENERAL MARKET</b> SHEET NUMBER: <b>1 OF 3</b>		
DRAFT WHERE APPLICABLE MUST REMAIN WITHIN DIMENSIONS		THIRD ANGLE PROJECTION	DRAWING: <b>D-SIZE</b>	SERIES: <b>160027</b>	

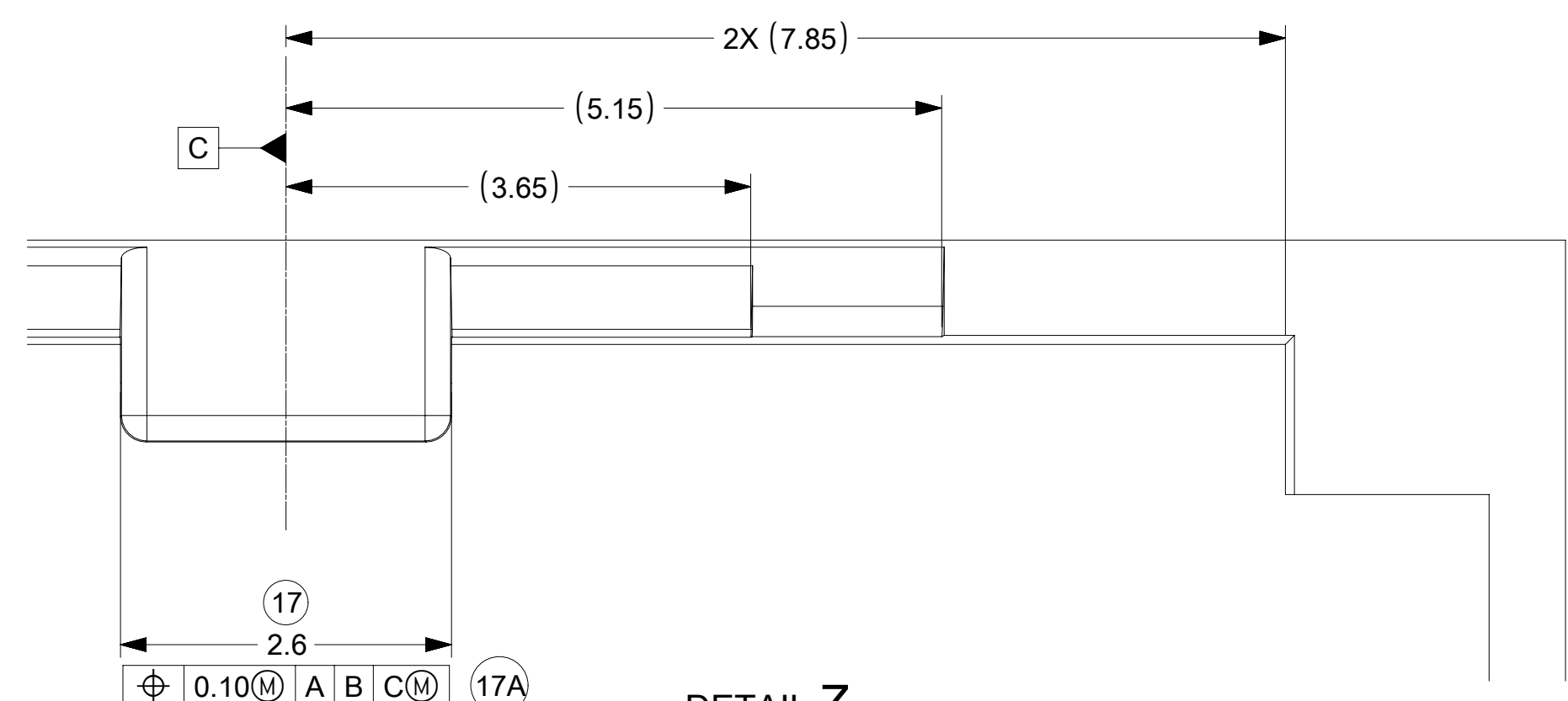

DETAIL Z  
SCALE 20:1

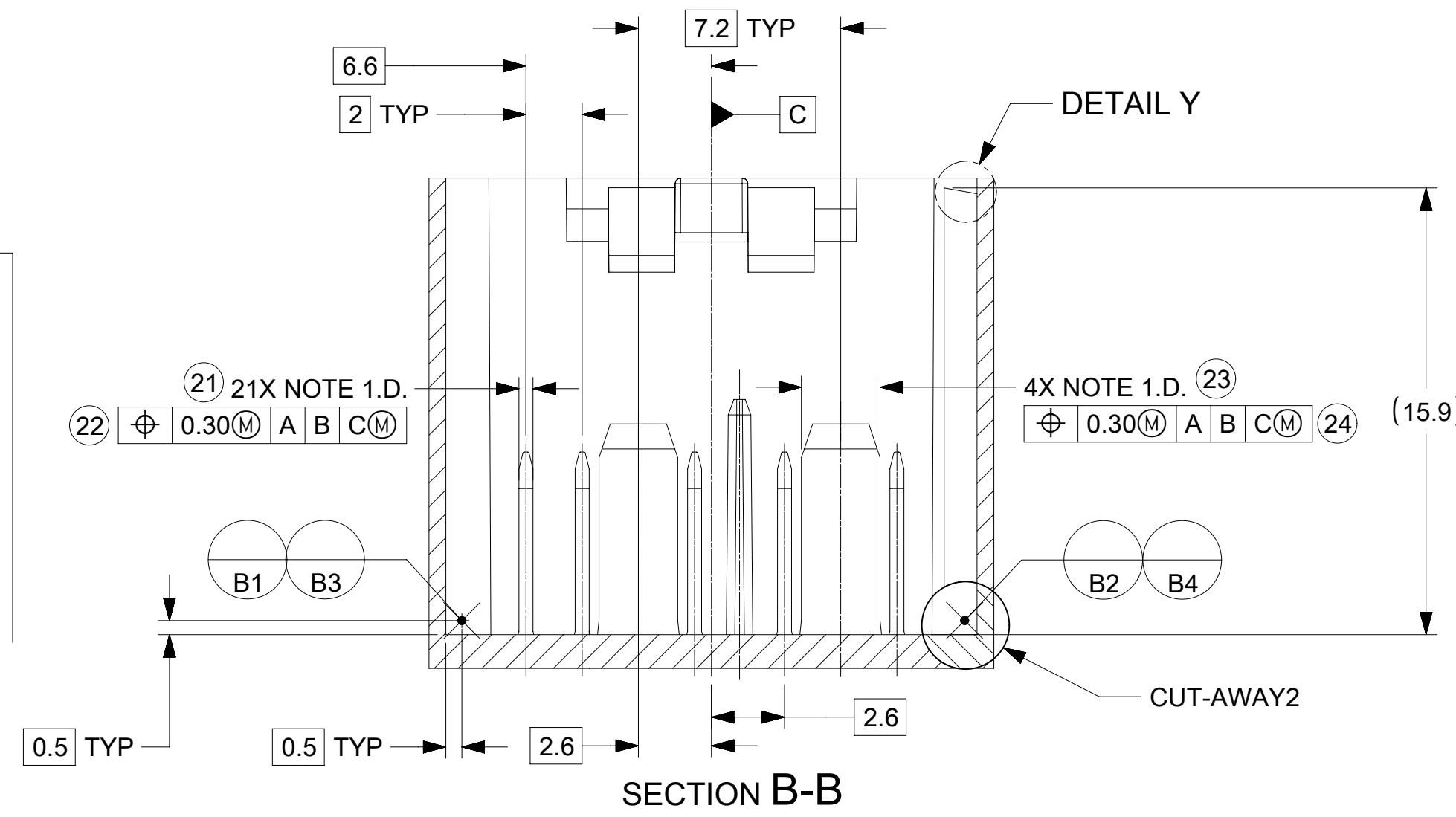

SECTION B-B

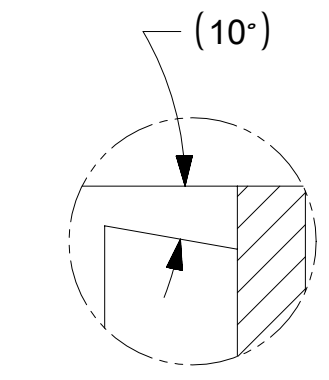

DETAIL Y  
SCALE 15:1

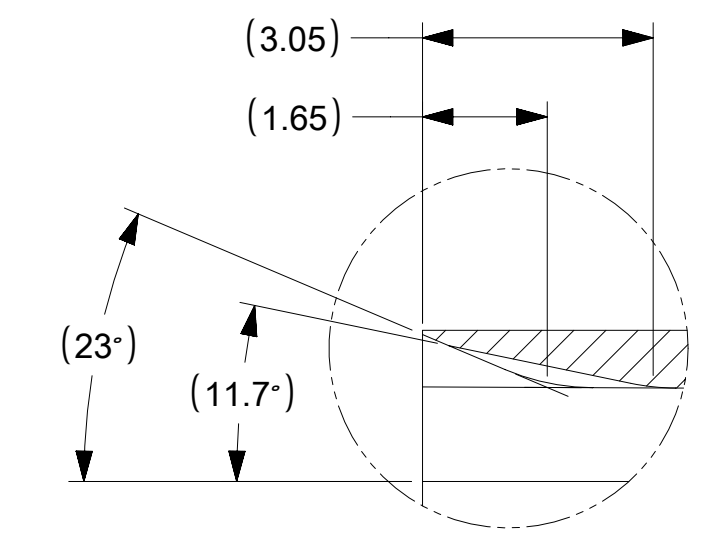

DETAIL X  
SCALE 10:1

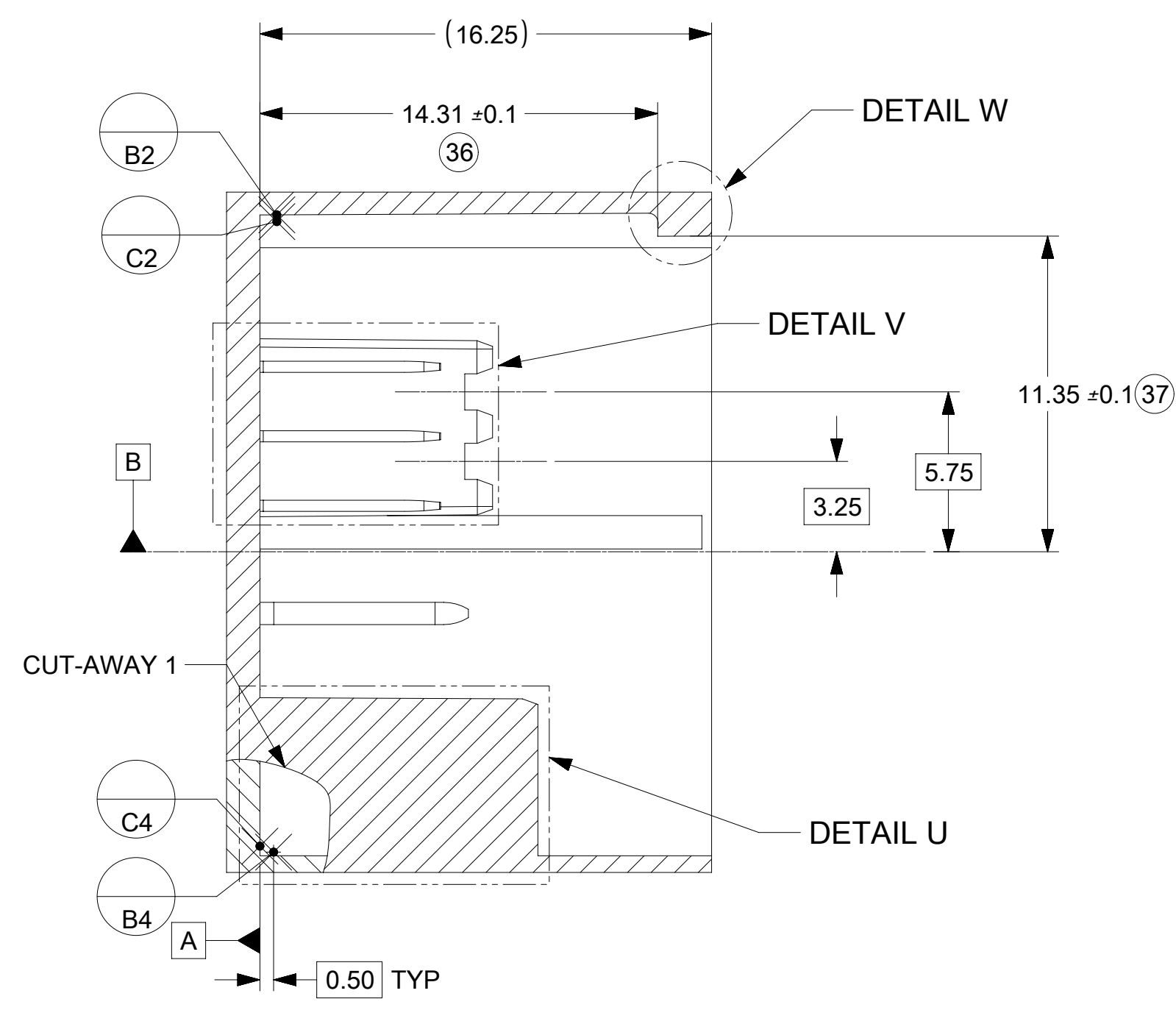

SECTION A-A

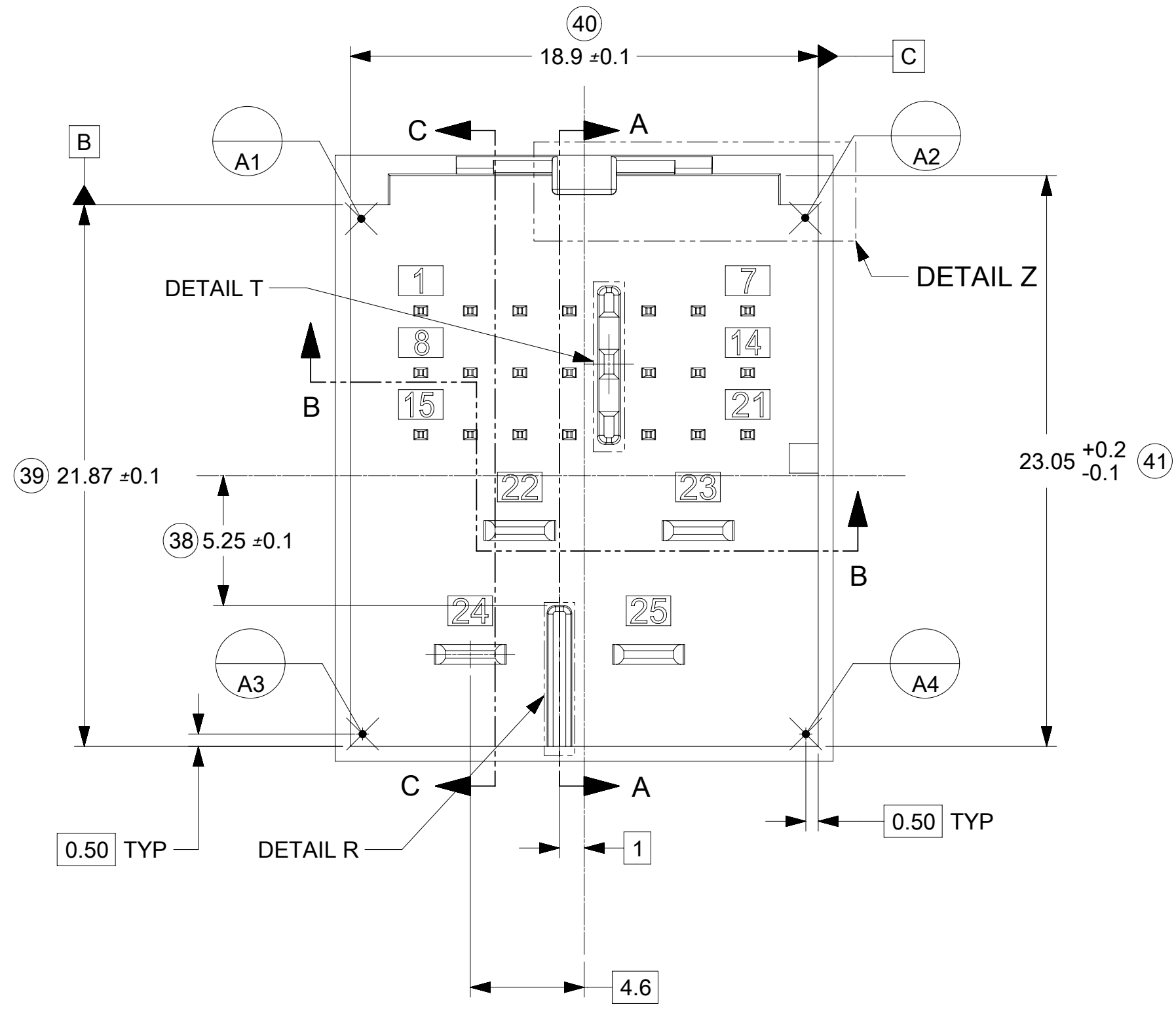

SECTION C-C

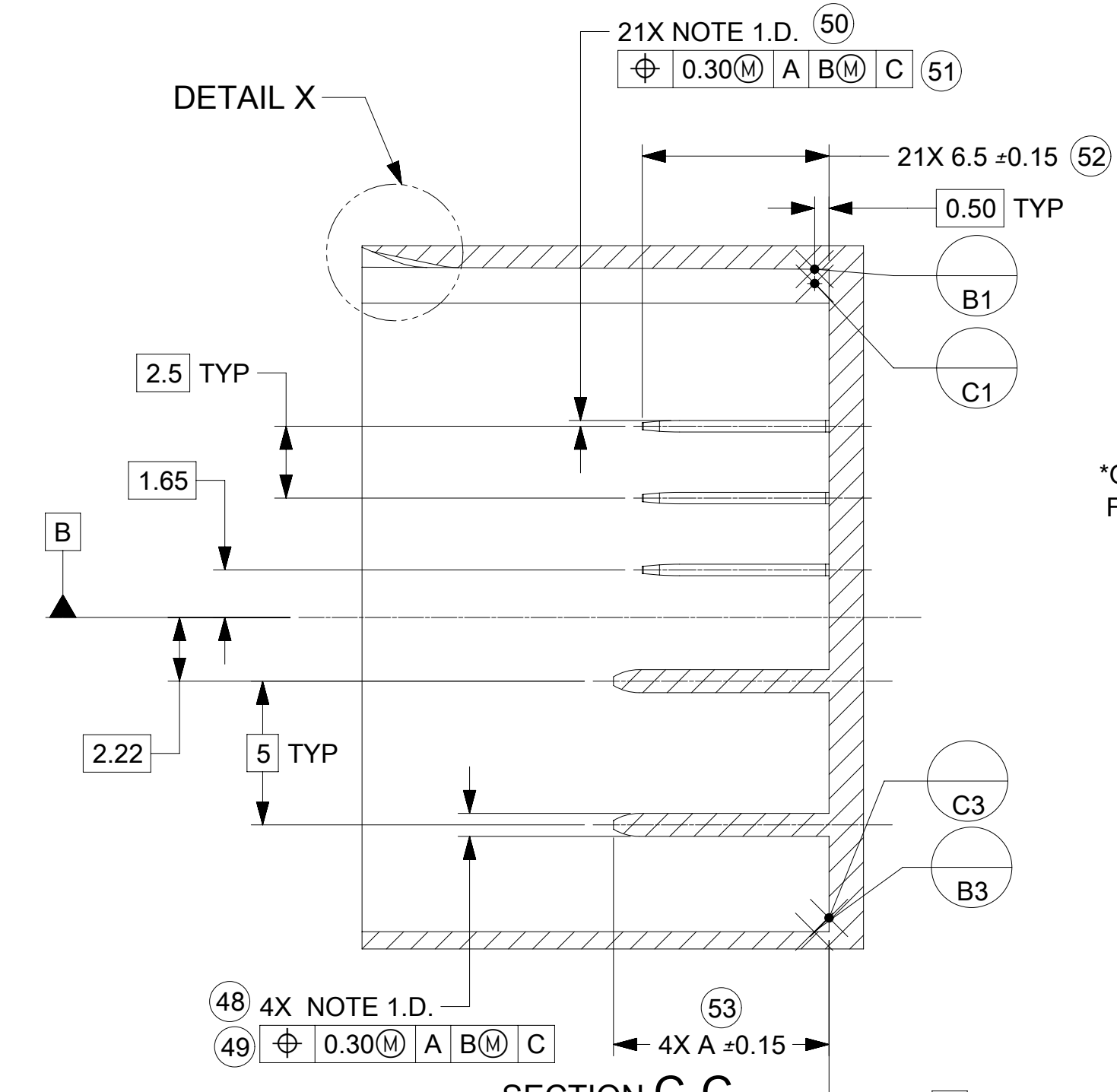

CONSTRUCTION	DIM. A (mm)	STATUS
OPTION A	7.5	REVISION B
OPTION B	6.5	REVISION C

\*OPTION B IS THE PREFERRED CONSTRUCTION FOR ALL NEW HEADERS

DETAIL T  
SCALE 10:1

DETAIL R  
SCALE 10:1

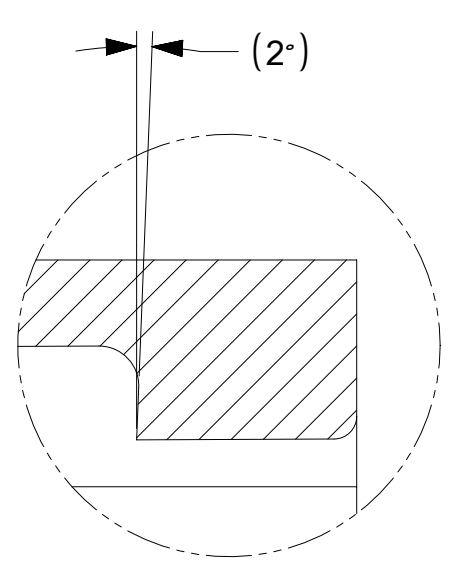

DETAIL W  
SCALE 15:1

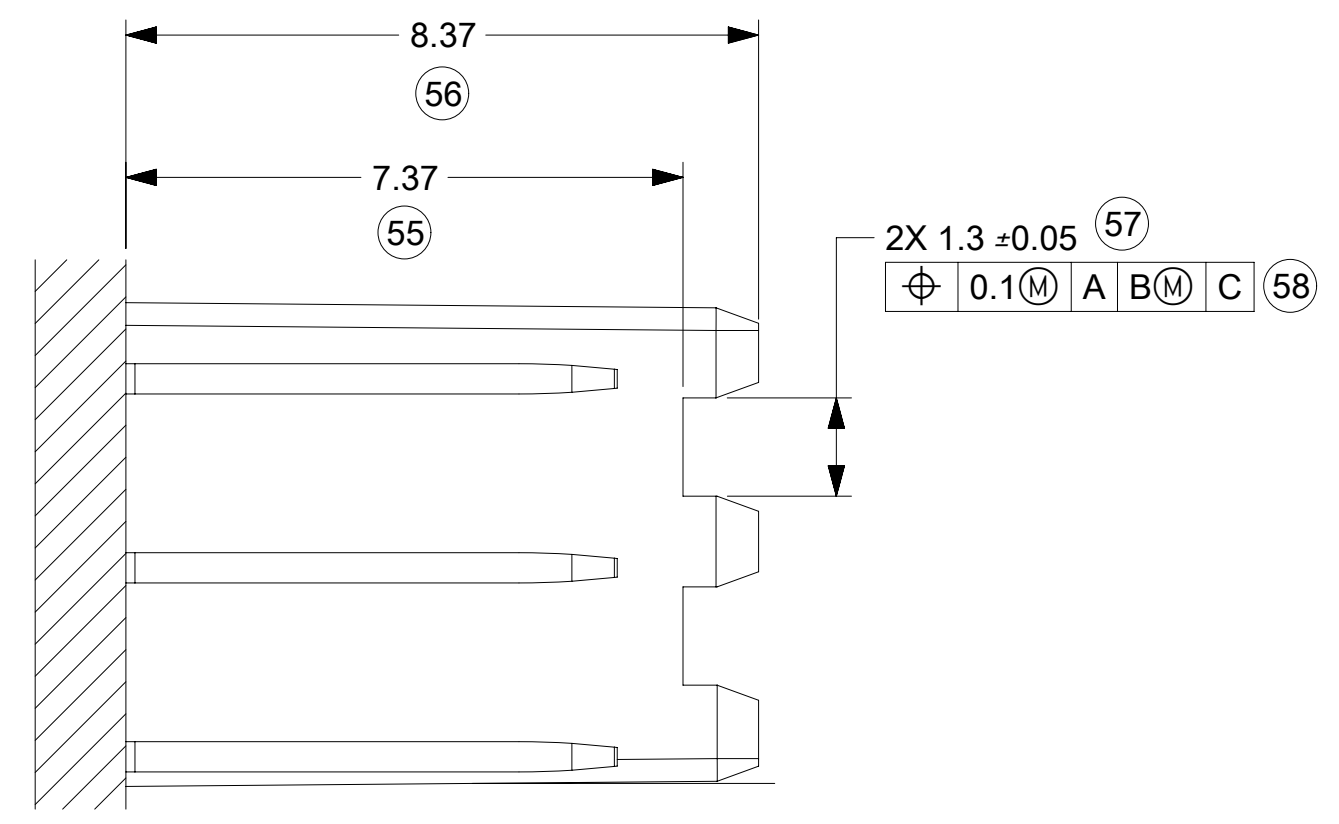

DETAIL V  
SCALE 10:1

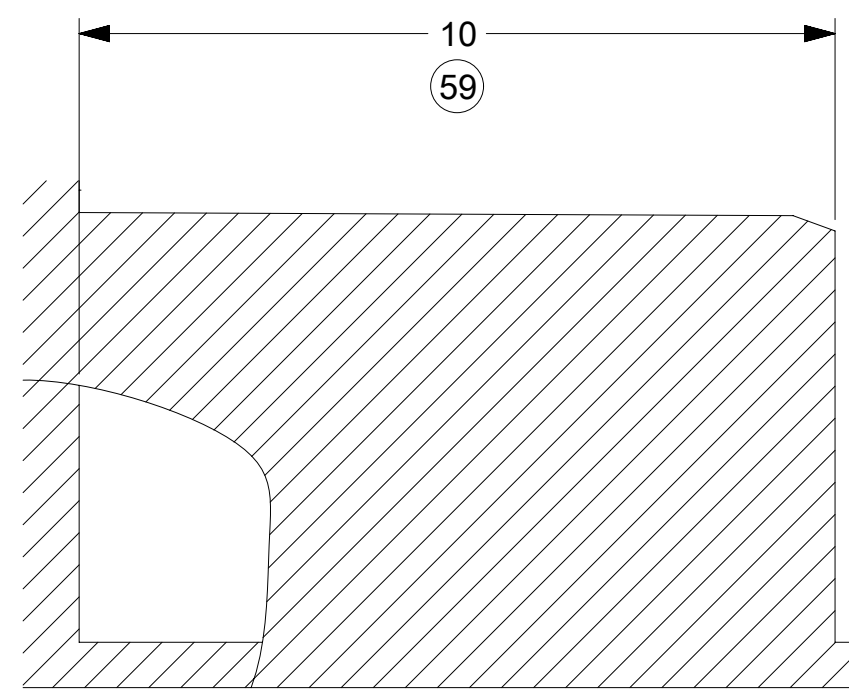

DETAIL U  
SCALE 10:1

FUNCTIONAL SYMBOLS FA = 0 FC = 0 FP = 0	THIS DRAWING CONTAINS INFORMATION THAT IS PROPRIETARY TO MOLEX ELECTRONIC TECHNOLOGIES, LLC AND SHOULD NOT BE USED WITHOUT WRITTEN PERMISSION	SCALE 5:1	CURRENT REV DESC: UPDATED BASIC DIMENSIONS IN SECTION B-B ON SHEET 2	
	DIMENSION UNITS mm	GENERAL TOLERANCES (UNLESS SPECIFIED)	EC NO: 649575	
DIVISIONAL SYMBOLS	ANGULAR TOL ± °	4 PLACES ±	DRWN: YPENG47	2020/11/19
	3 PLACES ±	2 PLACES ±	CHK'D: JRUTTER	2020/11/23
DRAFT WHERE APPLICABLE MUST REMAIN WITHIN DIMENSIONS	1 PLACE ±	0 PLACES ±	APPR: MVANSLAMBROU	2020/11/25
	THIRD ANGLE PROJECTION	INITIAL REVISION:	DRWN: SPEMMARAJU	2015/11/03
SEE NOTES	DRAWING	SERIES	APPR: KDEKOSKI	2016/03/24
	D-SIZE	160027	MATERIAL NUMBER CUSTOMER SHEET NUMBER	
			SD-160027-002	PSD 000 C1
			GENERAL MARKET 2 OF 3	



PACKAGE SPACE  
FOR UNMATED  
CONNECTOR

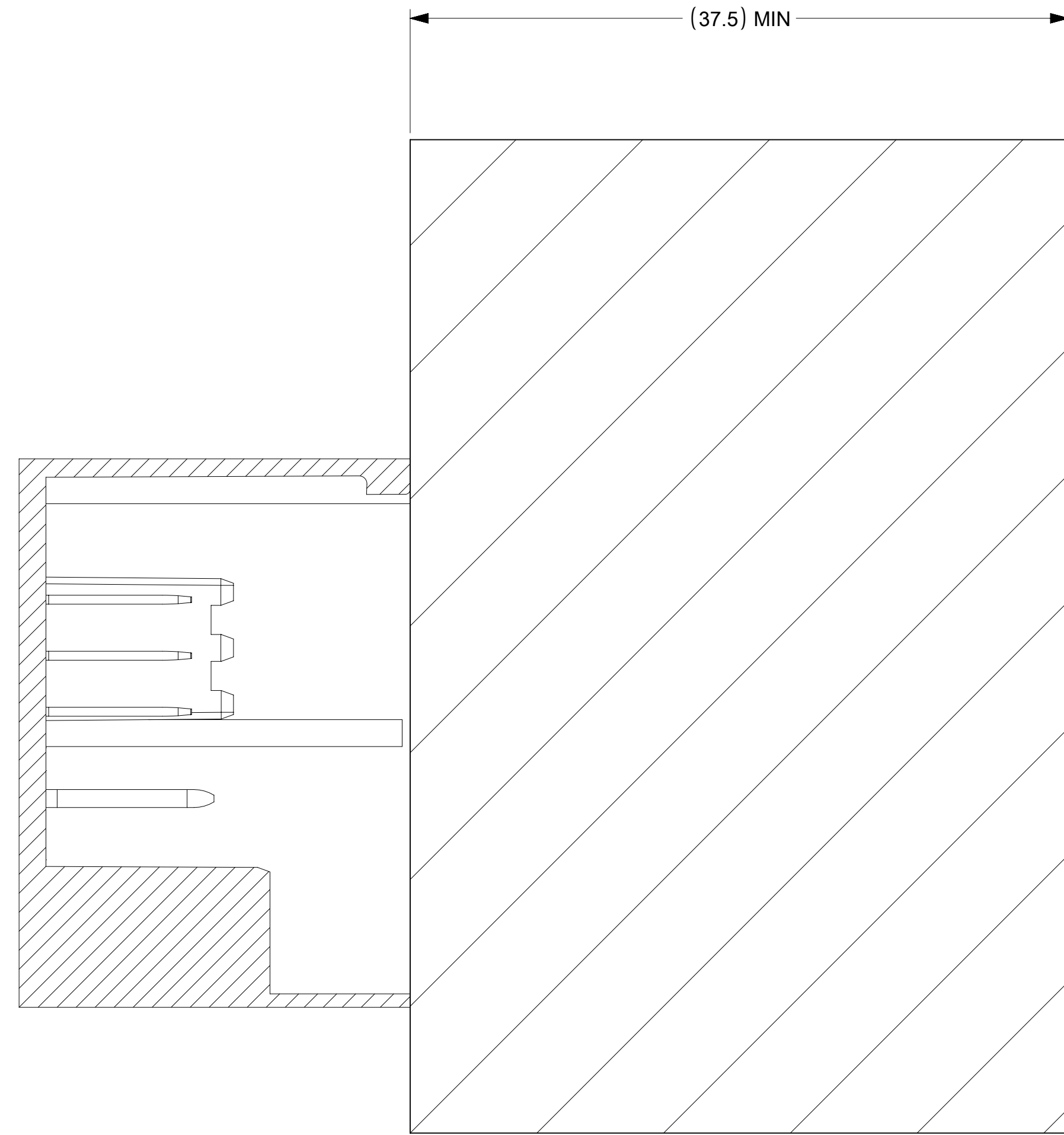

PACKAGE SPACE  
FOR CONNECTOR

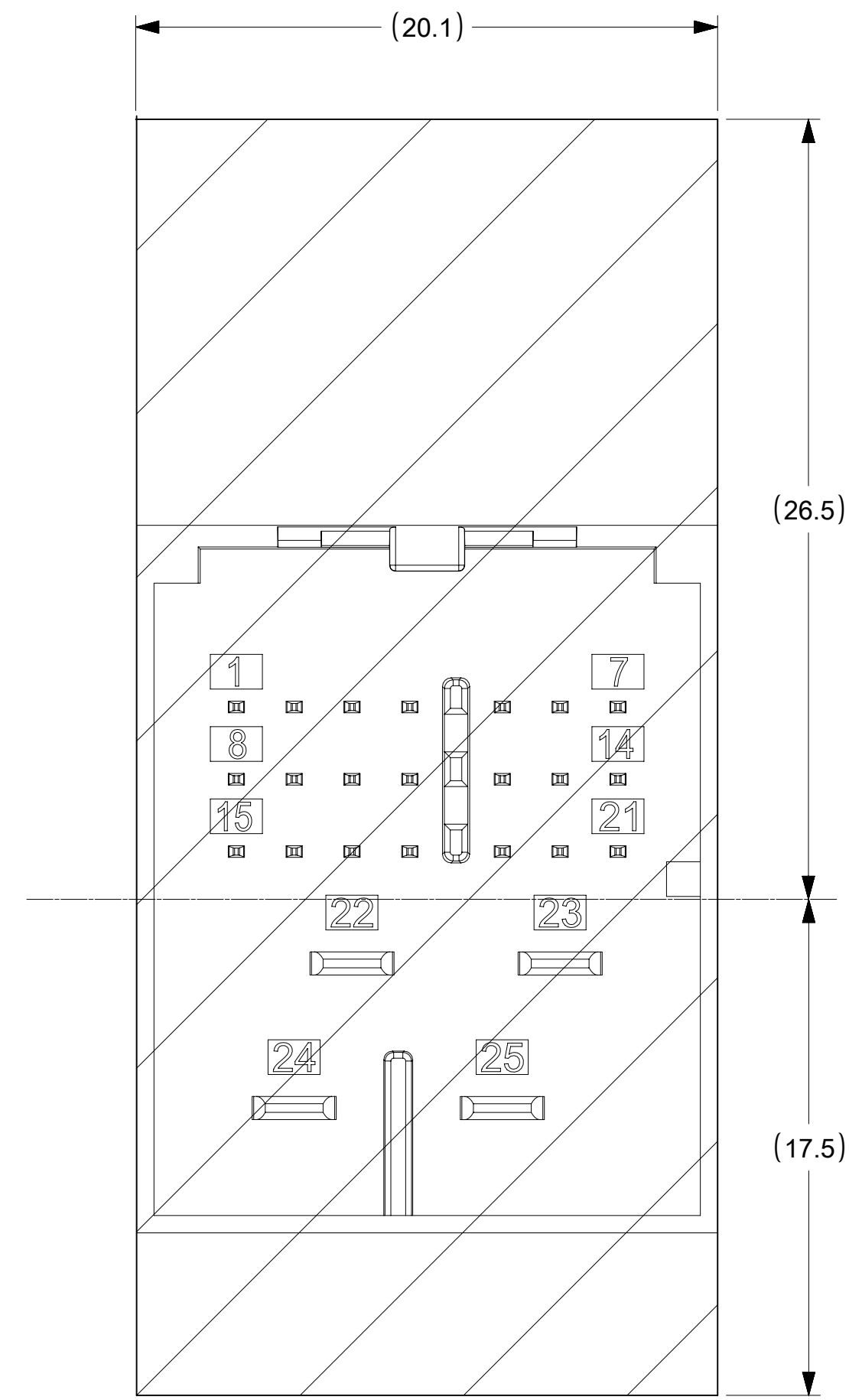

PACKAGE SPACE FOR  
MATED CONNECTOR  
WITH COVER

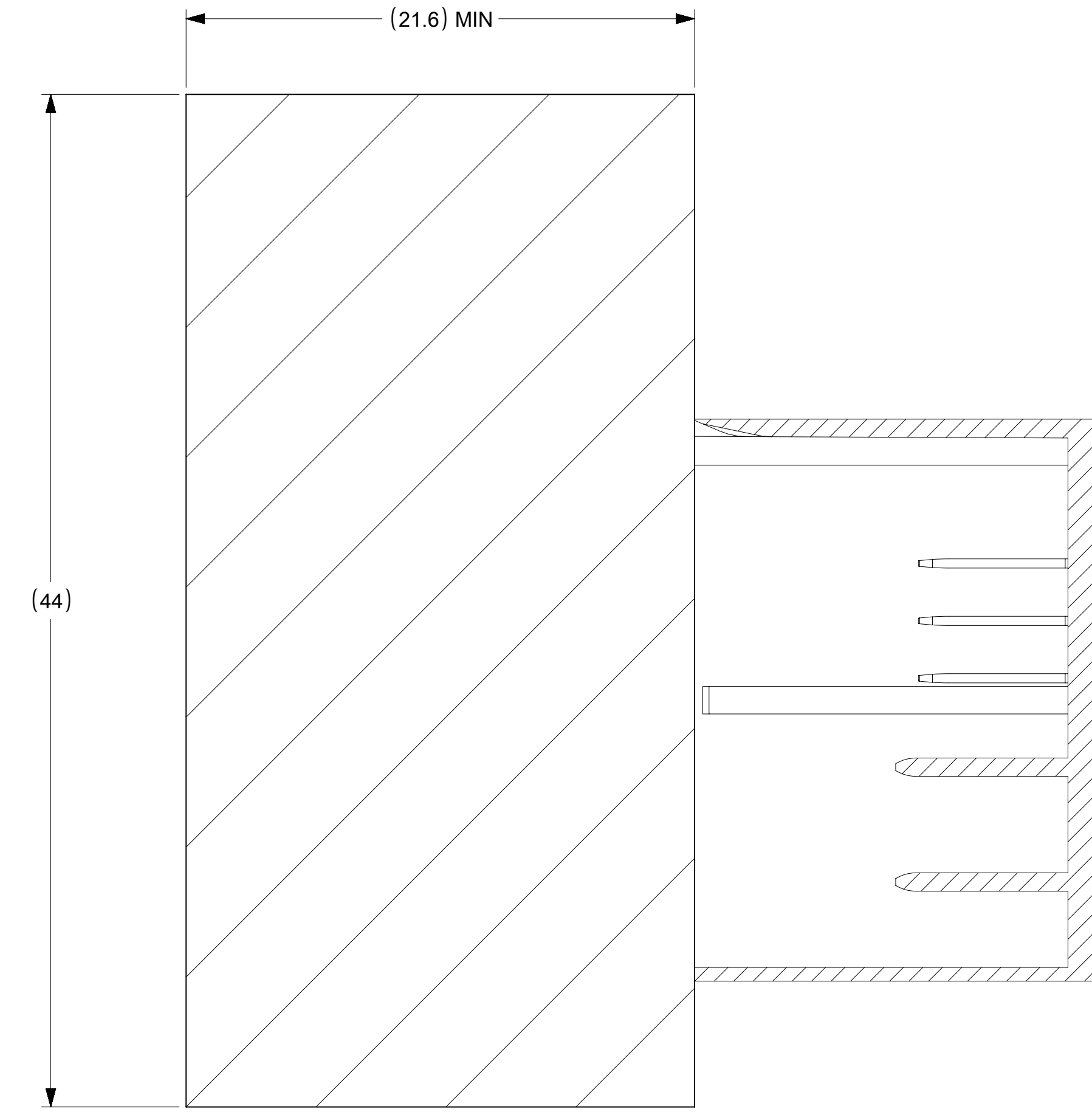

FUNCTIONAL SYMBOLS FA = 0 FC = 0 FD = 0	THIS DRAWING CONTAINS INFORMATION THAT IS PROPRIETARY TO MOLEX ELECTRONIC TECHNOLOGIES, LLC AND SHOULD NOT BE USED WITHOUT WRITTEN PERMISSION		CURRENT REV DESC: UPDATED BASIC DIMENSIONS IN SECTION B-B ON SHEET 2		
	DIMENSION UNITS mm	SCALE 1:1			
DIVISIONAL SYMBOLS	GENERAL TOLERANCES (UNLESS SPECIFIED)		EC NO: 649575		25WAY STAK50H INTERFACE DRAWING  PRODUCT CUSTOMER DRAWING  DOCUMENT NUMBER: SD-160027-002    DOC TYPE: PSD    DOC PART: 000    REVISION: C1
	ANGULAR TOL ± °		DRWN: YPENG47    2020/11/19		
	4 PLACES ±		CHK'D: JRUTTER    2020/11/23		
	3 PLACES ±		APPR: MVANSLAMBROU    2020/11/25		
	2 PLACES ±		INITIAL REVISION: DRWN: SPEMMARAJU    2015/11/03		
1 PLACE ±		APPR: KDEKOSKI    2016/03/24		MATERIAL NUMBER: 160027    CUSTOMER: GENERAL MARKET    SHEET NUMBER: 3 OF 3	
0 PLACES ±		DRAFT WHERE APPLICABLE MUST REMAIN WITHIN DIMENSIONS			
		THIRD ANGLE PROJECTION	DRAWING	SERIES	
			D-SIZE	160027	