

PART NUMBER	REVISION	DESCRIPTION	FEED TYPE
2151084-1	D	FINE CRIMP HEIGHT ADJUST	MECHANICAL
2151084-2	E	FINE CRIMP HEIGHT ADJUST	PNEUMATIC
7-2151084-1	D	MECHANICAL AND CRIMP TOOLING KIT	MECHANICAL
7-2151084-2	E	PNEUMATIC AND CRIMP TOOLING KIT	PNEUMATIC
7-2151084-7	A	CRIMP TOOLING KIT	-

ATLANTIC VERSION TERMINATOR INTERFACE ADAPTER

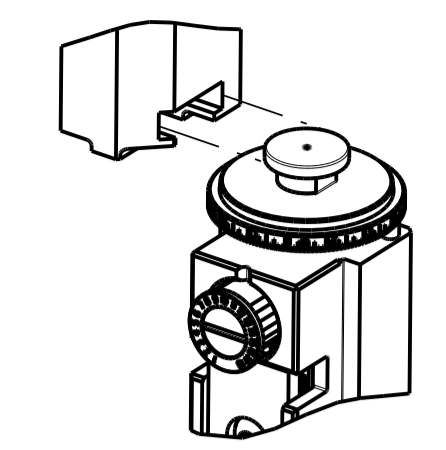

APPLICATOR DATA		
CRIMP	SIZE	TYPE
WIRE	1.07 mm [.042]	F
INSUL	1.57 mm [.062]	O

APPLICATOR INSTRUCTIONS 408-35042

TERMINAL DATA: TE TERMINAL		TE CRIMP SPECIFICATION	
TERMINAL NAME: CONTACT CRIMP SNAP IN AMP EI SERIES			
WIRE STRIP LENGTH		INSULATION DIAMETER RANGE	
2.83-3.59 mm [.111-.141 IN]		Ø1.00-1.40 mm [.039-.055 IN]	
TERMINAL APPLICATION SPECIFICATION	114-5035		
TERMINALS APPLIED			
TE TERMINAL	TE TERMINAL	TE TERMINAL	TE TERMINAL
170263-1	170263-2	170263-3	170263-4
170377-1	170377-2	170377-3	170377-4

WIRE SIZE	CRIMP HEIGHT mm [INCH]	CRIMP HEIGHT REFERENCE SETTING
26 AWG	0.66 +/- 0.05 [.026 +/- .002]	6.3
28 AWG	0.62 +/- 0.05 [.024 +/- .002]	6.8
30 AWG	0.59 +/- 0.05 [.023 +/- .002]	7.2

- 1. RECOMMENDED SPARE PARTS
- 2. REFER TO SUPPLIED INSTRUCTION SHEET FOR CLEANING, LUBRICATION AND STORAGE OF APPLICATOR.
- 3. APPLY PART NUMBER 2-23419-6 LOCTITE TO THREADS OF ITEM 242.
- 4. CRIMP HEIGHT REFERENCE SETTING WAS THE SETTING USED WHEN THE APPLICATOR WAS QUALIFIED AT THE FACTORY. ADJUSTMENT MAY BE NECESSARY WHEN RUNNING APPLICATOR IN THE FIELD.
- 5. UNLESS SPECIFIED OTHERWISE TORQUE VALUES SHALL BE USED PER DOCUMENT, 101-35000.

*WARNING
ON INSTALLATION, SET WIRE DISC TO CRIMP HEIGHT REFERENCE SETTING FOR LARGEST WIRE SIZE. CRIMP HEIGHT REFERENCE SETTINGS GREATER THAN THE VALUE SHOWN MAY CAUSE DAMAGE TO THE CRIMP TOOLING, REFER TO THE INSTRUCTION SHEET FOR PROPER SETUP AND ADJUSTMENTS.

ATLANTIC VERSION
Shown on sheets 1 of 4 & 2 of 4
(Pacific version shown on sheets 3 of 4 & 4 of 4)

LOC	DIST	REV	LTN	DESCRIPTION	DATE	OWN	APVD
A	66	B2		ECR-16-010395	19JUL2016	MZ	KZ
		C		ECR-17-010821	25JUL2017	AW	CT
		D		ECR-19-004801	26MAR2019	FZ	YY
		E		ECR-21-002757	04MAR2021	FZ	TE

-	1	-	1	-	2119641-1	FEED CAM, AIR FEED	248	
-	1	1	1	1	2119082-5	CAM, SNAIL, INSULATION ADJUSTMENT	244	
-	1	1	1	1	2079764-1	WASHER, WAVE SPRING, CREST-TO-CREST	243	
-	1	1	1	1	2119083-1	RETAINER, INSULATION DIAL	242	
-	1	1	1	1	7-18023-7	SCR, SKT HD CAP M3 X 4.0	241	
-	-	1	-	1	2119580-1	MECHANICAL FEED ASSEMBLY	239	
-	1	-	1	-	2844940-1	AIR FEED MODULE	238	
-	REF	REF	REF	REF	994970-2	COUNTER, MAGNETIC	164	
-	1	1	1	1	2844908-1	SCREW, LOCKING	99	
-	1	1	1	1	2844907-1	POST, LOCKING	98	
-	1	1	1	1	455888-6	SPACER, CRIMPER	82	
-	1	1	1	1	1962431-2	SPRING, COMPRESSION	77	
-	1	1	1	1	854769-4	HOLDER, INS	74	
-	1	1	1	1	1803607-3	DOCUMENTATION PACKAGE	71	
-	1	1	1	1	2119740-1	TAG, IDENTIFICATION	67	
-	2	2	2	2	2168078-1	SCREW, DRIVE, RH, RoHS, 2 x .188	66	
-	1	1	1	1	2168083-2	SCR, SKT HD CAP, RoHS, M4 X 8.0	60	
-	1	1	1	1	5-18022-5	SCR, HEX HD CAP, M4 X 6.0	59	
-	1	1	1	1	21028-2	PIN, SLOTTED SPRING .062 X .250	58	
-	1	1	1	1	1338685-1	PAWL, FEED	56	
-	4	4	4	4	2168083-3	SCR, SKT HD CAP, RoHS, M4 X 12.0	54	
-	2	2	2	2	1-2168083-0	SCR, SKT HD CAP, RoHS, M4 X 10	53	
-	1	1	1	1	5018030-1	NUT, HEX, REG, RoHS, M3	52	
-	1	1	1	1	811242-5	BUMPER, HOLD DOWN	51	
-	1	1	1	1	690753-2	SPACER, TONKER	50	
-	1	2	1	2	18023-9	SCR, SKT HD CAP M4 X 6.0	49	
-	-	1	-	1	2119652-1	FEED CAM, PRE FEED	48	
-	-	1	-	1	2119653-1	FEED CAM, POST FEED	47	
-	1	1	1	1	1803583-9	APPLICATOR BASIC ASSEMBLY, SF	46	
-	1	1	1	1	1803515-1	RAM ASSEMBLY, SF ATLANTIC	44	
-	1	1	1	1	1803602-1	SCR, BHSC, RoHS (M8 X 25)	41	
-	1	1	1	1	1752356-3	SUPPORT, TERMINAL	34	
-	2	2	2	2	2079383-5	SCR, BHSC, RoHS (M4 X 20)	33	
-	2	2	2	2	2-2844962-4	SPACER, CYLINDRICAL, STRIP GUIDE	30	
-	1	1	1	1	2844992-1	ASSEMBLY, STRIP GUIDE	29	
-	1	1	1	1	455888-3	SPACER, CRIMPER	28	
-	1	1	1	1	1320928-2	STRIP GUIDE	24	
-	1	1	1	1	2168083-2	SCR, SKT HD CAP, RoHS, M4 X 8.0	21	
-	2	2	2	2	1-18028-2	WASHER, FLAT, REG M4	20	
-	1	1	1	1	2119533-4	STRIPPER, SIDE FEED	19	
-	1	1	1	1	2119806-1	INSERT, SHEAR	13	
-	1	1	1	1	3-22280-3	SPRING, COMPRESSION	12	
-	1	1	1	1	1-356885-4	STOP, SHEAR	11	
-	1	1	1	1	2119805-1	SHEAR HOLDER, FRONT	10	
-	1	1	1	1	1803095-6	FLOATING SHEAR, FRONT	9	
-	1	2	2	1	1	2-1803056-0	ANVIL, COMBINATION	8
-	-	-	-	-	-	-	7	
-	-	-	-	-	-	-	6	
-	1	1	1	1	2119780-4	DEPRESSOR, SHEAR	5	
-	1	1	1	1	238011-7	BLOCK, CRIMPER SPACER	4	
-	1	2	2	1	1	1633966-6	CRIMPER, INSULATION O	3
-	1	1	1	1	455888-3	SPACER, CRIMPER	2	
-	1	2	2	1	1	1-1803454-1	CRIMPER, WIRE	1
-	77	72	71	-2	-1	PART NO	ITEM NO	

DIMENSIONS:		TOLERANCES UNLESS OTHERWISE SPECIFIED:		OWN J.HOU 17SEP2014		TE Connectivity	
mm		0 PLC ±		CHK Y.YIN 17SEP2014		Harrisburg, PA 17105-3608	
		1 PLC ±		APVD H.GUO 17SEP2014		NAME	
		3 PLC ±				Ocean Side Feed	
		4 PLC ±				Applicator	
		ANGLES ±				SIZE CAGE CODE DRAWING NO RESTRICTED TO	
MATERIAL		FINISH		WEIGHT		A1 00779 C=2151084	
						Customer Accessible Production Drawing SCALE 1:2 SHEET 1 OF 4 REV E	

LOC		REVISONS	
NO.	DATE	DESCRIPTION	BY
A	66	SEE SHEET 1	

FEED TYPE MECHANICAL

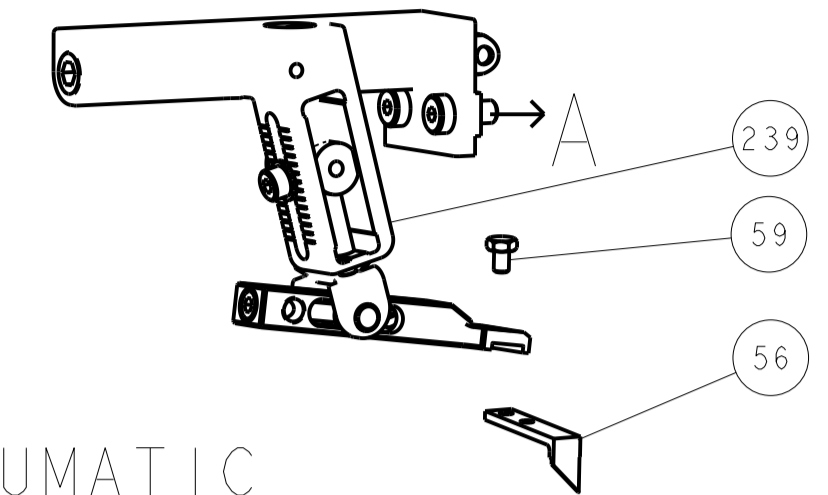

PNEUMATIC

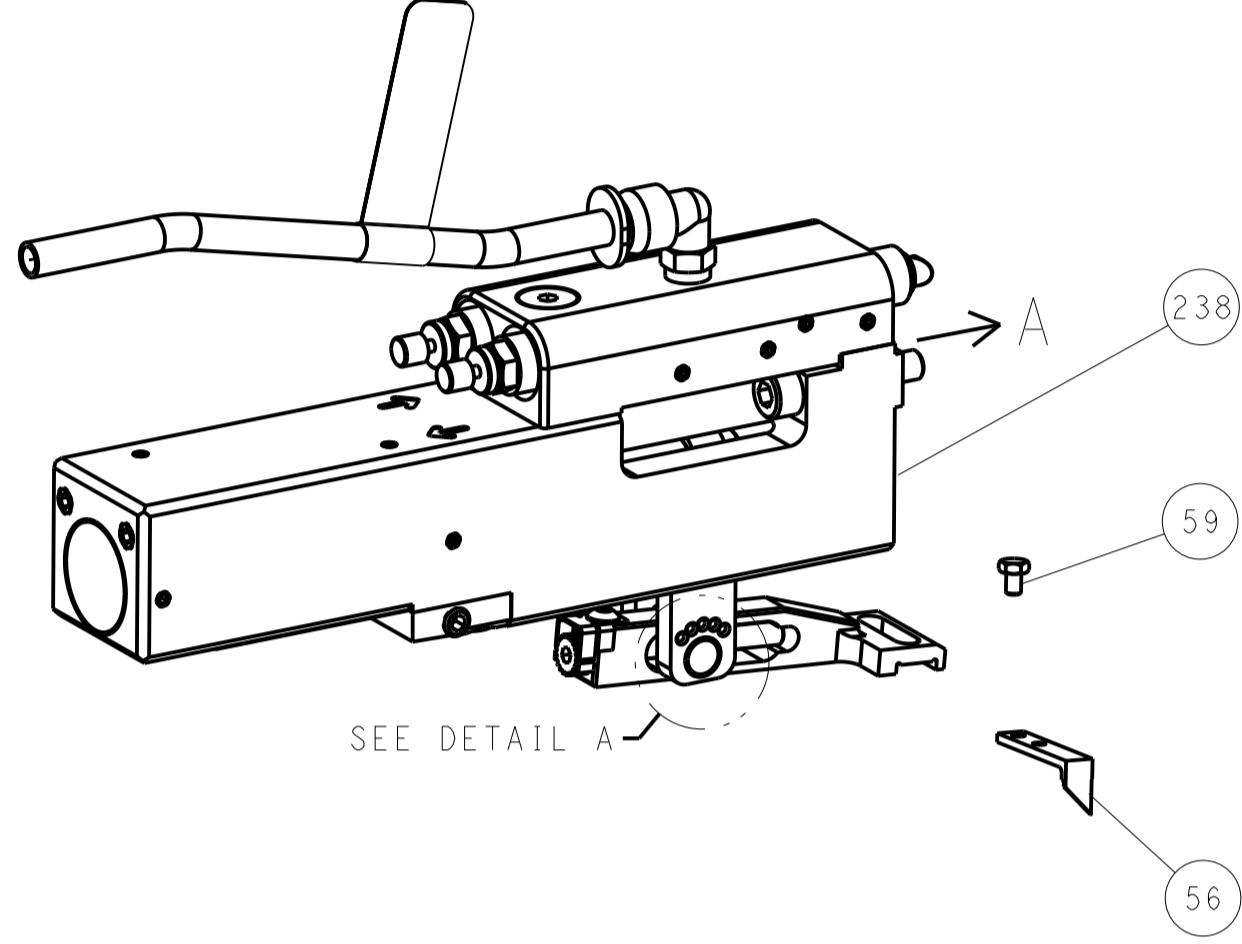

FEED SPRING SETTING POSITION (SHOWN FROM REAR SIDE)

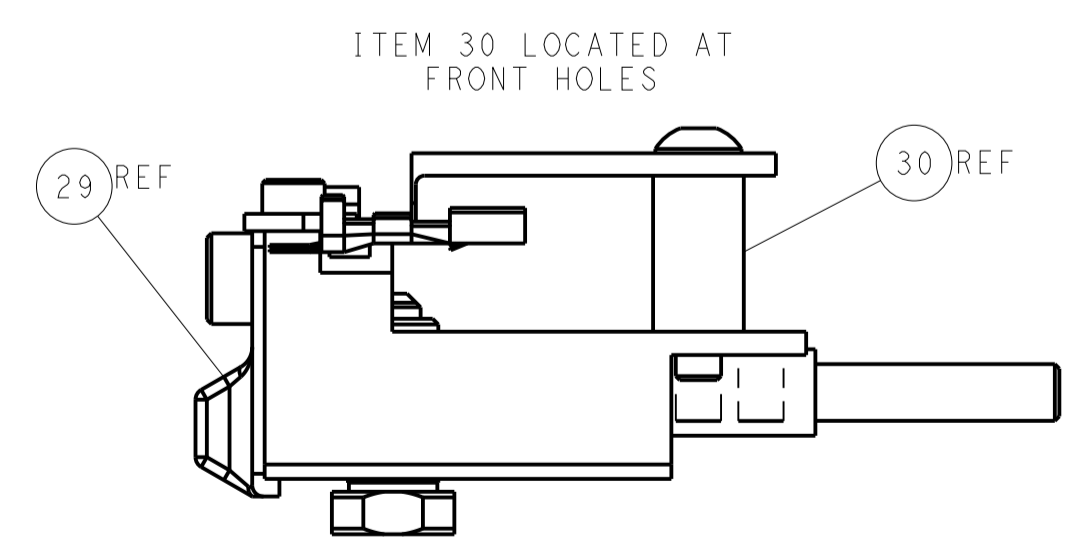
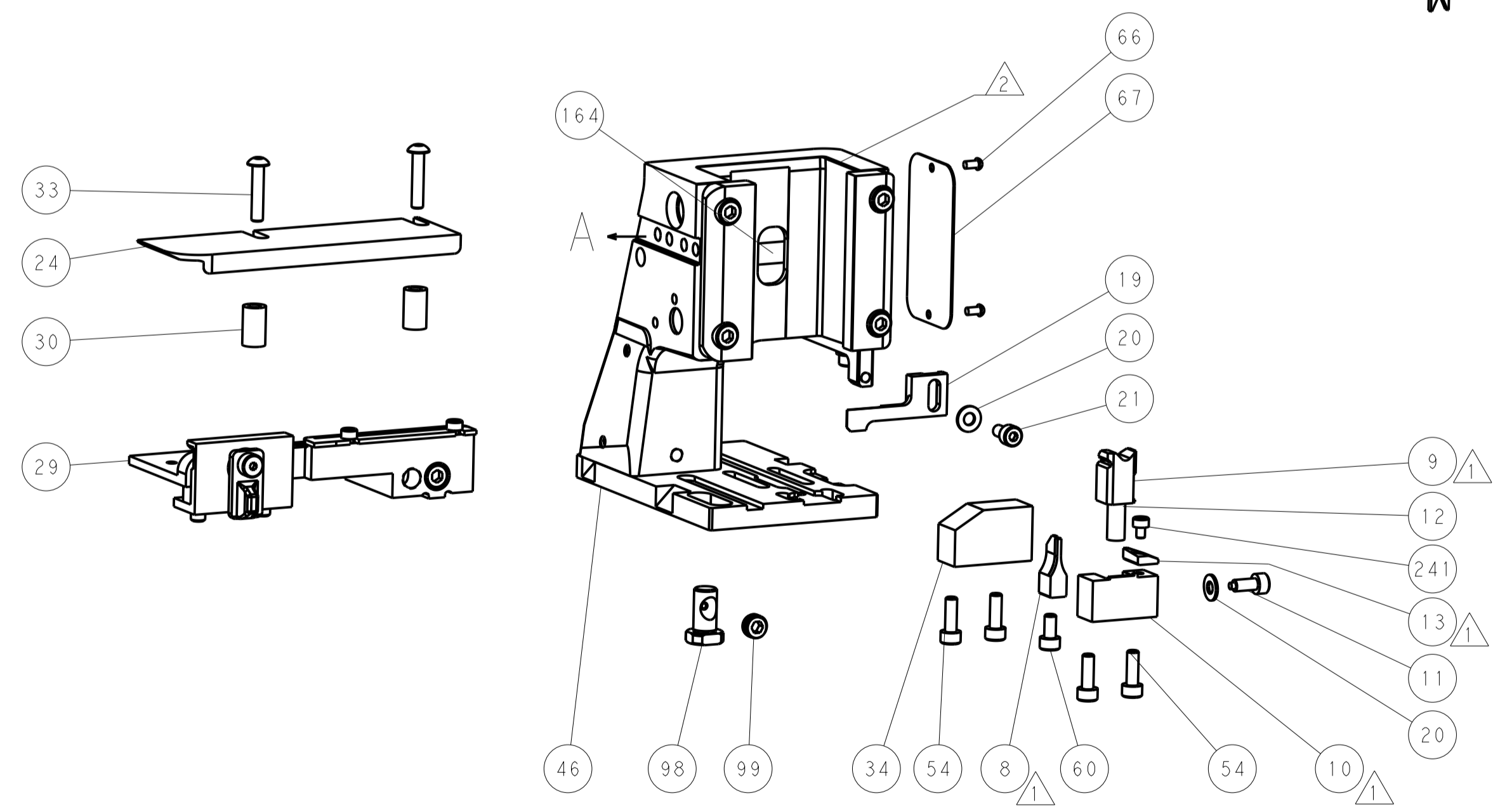
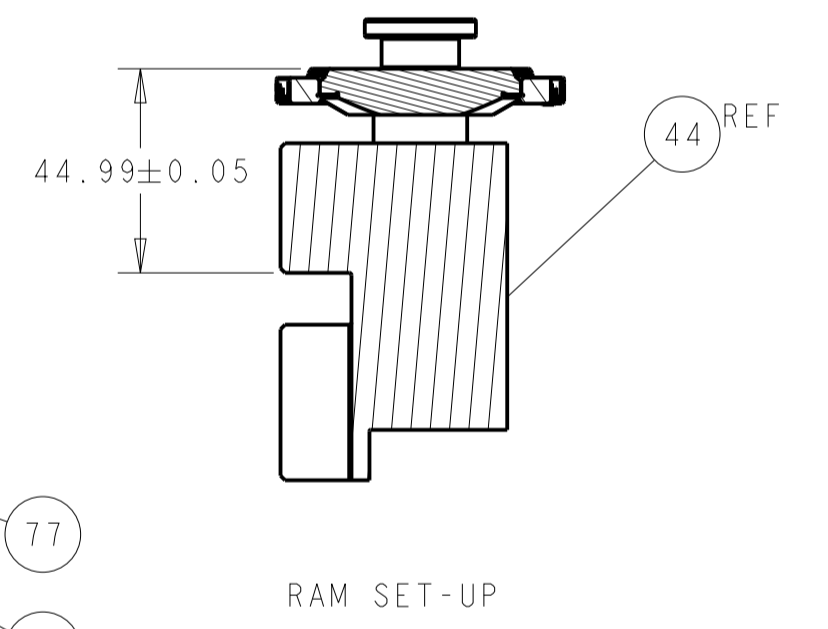
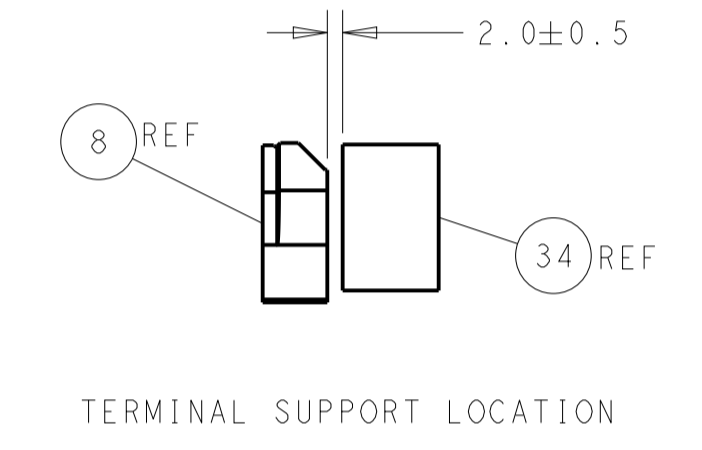
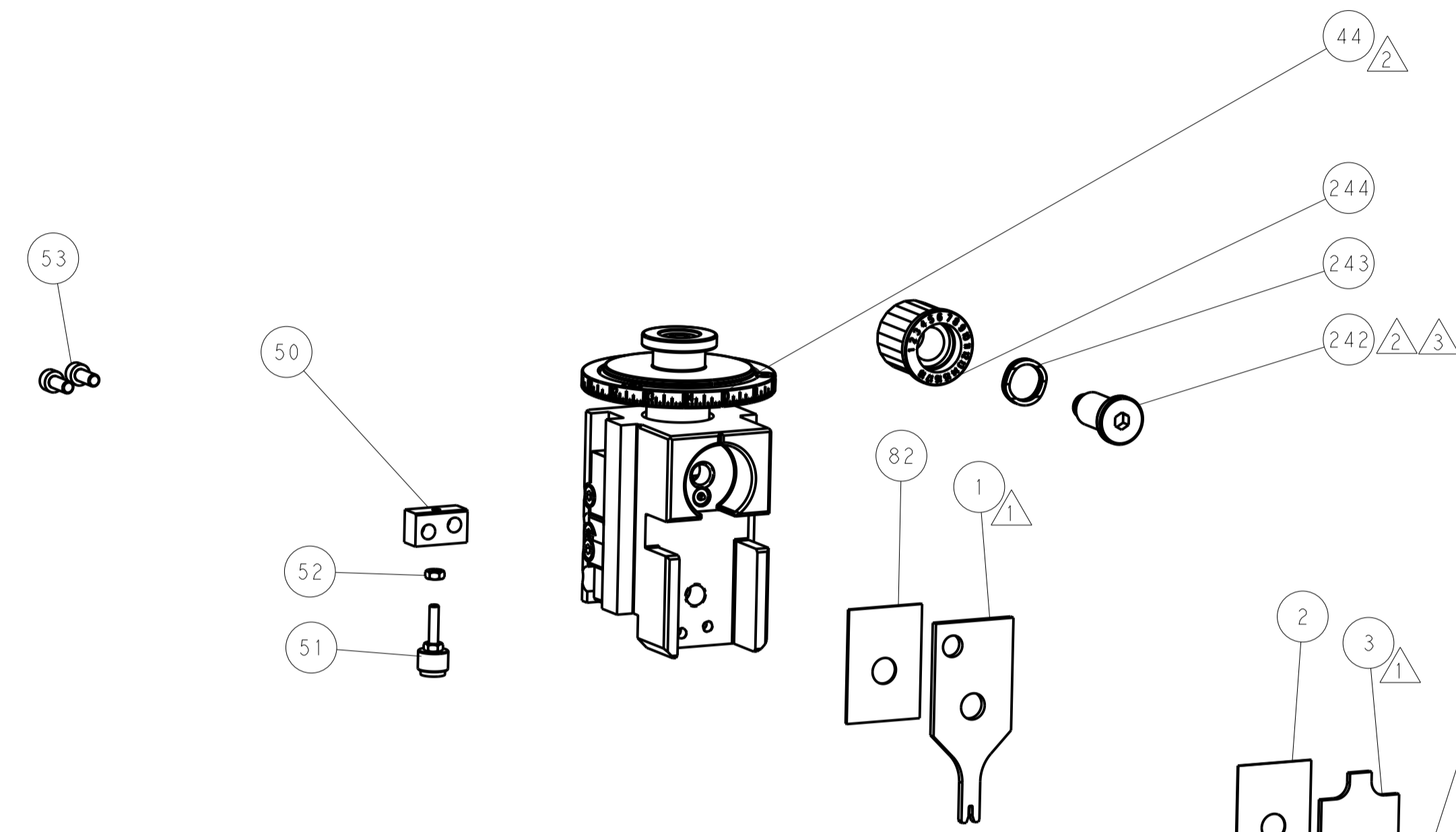
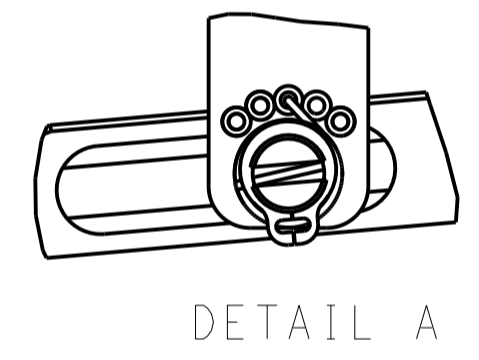

CAM POSITIONS

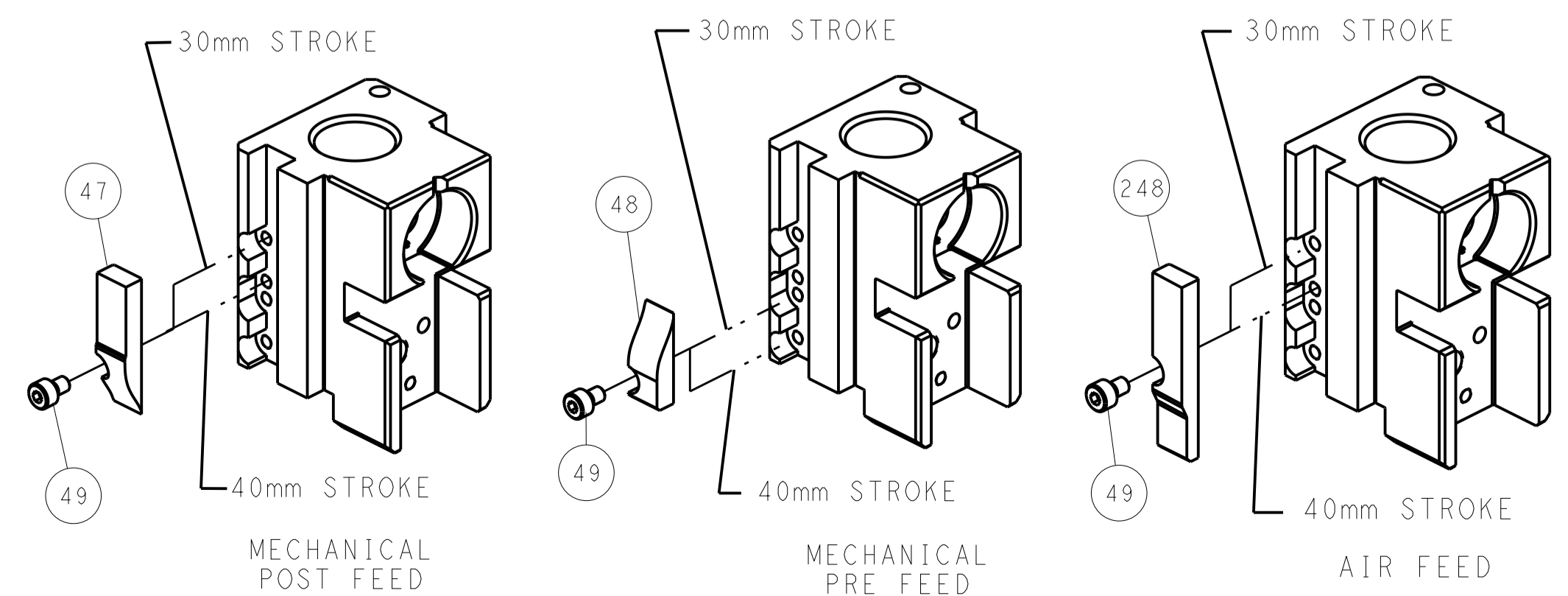

ATLANTIC VERSION
 Shown on sheets 1 of 4 & 2 of 4
 (Pacific version shown on sheets 3 of 4 & 4 of 4)

DIMENSIONS:		TOLERANCES UNLESS OTHERWISE SPECIFIED:		DWG: J.HOU 17SEP2014		TE Connectivity	
mm		0 PLC ±		CHK: Y.YIN 17SEP2014		Harrisburg, PA 17105-3608	
HOLE		1 PLC ±		APP'D: H.GUO 17SEP2014		NAME: Ocean Side Feed Applicator	
MATERIAL:		2 PLC ±		PRODUCT SPEC:		SIZE: CAGE CODE DRAWING NO. RESTRICTED TO	
FINISH:		3 PLC ±		APPLICATION SPEC:		A1 00779 ©=2151084	
		4 PLC ±		WEIGHT:		Customer Accessible Production Drawing SCALE: 1:2 SHEET 2 OF 4 REV E	
		ANGLES ±					

PART NUMBER	REVISION	DESCRIPTION	FEED TYPE
2-2151084-1	D	FINE CRIMP HEIGHT ADJUST	MECHANICAL
2-2151084-2	E	FINE CRIMP HEIGHT ADJUST	PNEUMATIC
7-2151084-7	A	CRIMP TOOLING KIT	-

PACIFIC VERSION TERMINATOR
 INTERFACE ADAPTER

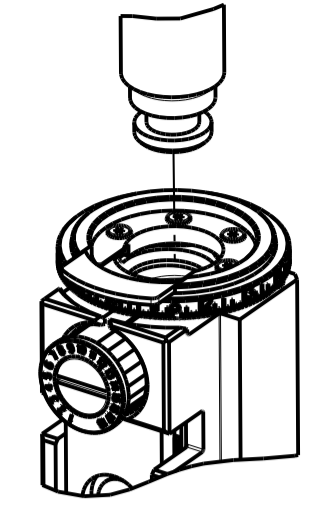

APPLICATOR DATA		
CRIMP	SIZE	TYPE
WIRE	1.07 mm [.042]	F
INSUL	1.57 mm [.062]	O

APPLICATOR INSTRUCTIONS
 408-35042

TERMINAL DATA: TE TERMINAL		TE CRIMP SPECIFICATION	
TERMINAL NAME: CONTACT CRIMP SNAP IN AMP EI SERIES			
WIRE STRIP LENGTH		INSULATION DIAMETER RANGE	
2.83-3.59 mm [.111-.141 IN]		∅1.00-1.40 mm [.039-.055 IN]	
TERMINAL APPLICATION SPECIFICATION	114-5035		
TERMINALS APPLIED			
TE TERMINAL	TE TERMINAL	TE TERMINAL	TE TERMINAL
170263-1	170263-2	170263-3	170263-4
170377-1	170377-2	170377-3	170377-4

WIRE SIZE	CRIMP HEIGHT mm [INCH]	CRIMP HEIGHT REFERENCE SETTING
26 AWG	0.66 +/- 0.05 [.026 +/- .002]	6.3
28 AWG	0.62 +/- 0.05 [.024 +/- .002]	6.8
30 AWG	0.59 +/- 0.05 [.023 +/- .002]	7.2



- △ RECOMMENDED SPARE PARTS
- △ REFER TO SUPPLIED INSTRUCTION SHEET FOR CLEANING, LUBRICATION AND STORAGE OF APPLICATOR.
- △ APPLY PART NUMBER 2-23419-6 LOCTITE TO THREADS OF ITEM 242.
- △ CRIMP HEIGHT REFERENCE SETTING WAS THE SETTING USED WHEN THE APPLICATOR WAS QUALIFIED AT THE FACTORY. ADJUSTMENT MAY BE NECESSARY WHEN RUNNING APPLICATOR IN THE FIELD.
- 5. UNLESS SPECIFIED OTHERWISE TORQUE VALUES SHALL BE USED PER DOCUMENT, 101-35000.

*WARNING
 ON INSTALLATION, SET WIRE DISC TO CRIMP HEIGHT REFERENCE SETTING FOR LARGEST WIRE SIZE. CRIMP HEIGHT REFERENCE SETTINGS GREATER THAN THE VALUE SHOWN MAY CAUSE DAMAGE TO THE CRIMP TOOLING, REFER TO THE INSTRUCTION SHEET FOR PROPER SETUP AND ADJUSTMENTS.

PACIFIC VERSION
 Shown on sheets 3 of 4 & 4 of 4
 (Atlantic version shown on sheets 1 of 4 & 2 of 4)

LOC	DIST	REV	DATE	BY	APPV
A	66				

REVISIONS					
REV	DATE	DESCRIPTION	DATE	BY	APPV
-	1	1	2119082-5	CAM, SNAIL, INSULATION ADJUSTMENT	244
-	1	1	2079764-1	WASHER, WAVE SPRING, CREST-TO-CREST	243
△	-	1	2119083-1	RETAINER, INSULATION DIAL	242
-	1	1	7-18023-7	SCR, SKT HD CAP M3 X 4.0	241
-	-	1	2119580-1	MECHANICAL FEED ASSEMBLY	239
-	1	-	2844940-1	AIR FEED MODULE	238
-	REF	REF	994970-2	COUNTER, MAGNETIC	164
-	1	-	2119641-2	FEED CAM, AIR FEED	151
-	1	1	2168083-8	SCR, SKT HD CAP, RoHS, M4 X 16	144
-	4	4	2168083-9	SCR, SKT HD CAP, RoHS, M4 X 20	143
-	-	1	2119653-2	FEED CAM, POST FEED	142
-	1	1	1-1803583-0	APPLICATOR BASIC ASSEMBLY, SF	141
-	1	1	1803516-1	RAM ASSEMBLY, SF PACIFIC	140
-	1	1	2844908-1	SCREW, LOCKING	99
-	1	1	2844907-1	POST, LOCKING	98
-	1	1	455888-6	SPACER, CRIMPER	82
-	1	1	1962431-2	SPRING, COMPRESSION	77
-	1	1	854769-4	HOLDER, INS	74
-	1	1	1803607-3	DOCUMENTATION PACKAGE	71
-	1	1	2119740-1	TAG, IDENTIFICATION	67
-	2	2	2168078-1	SCREW, DRIVE, RH, RoHS, 2 x .188	66
-	1	1	5-18022-5	SCR, HEX HD CAP, M4 X 6.0	59
-	1	1	21028-2	PIN, SLOTTED SPRING .062 X .250	58
-	1	1	1338685-1	PAWL, FEED	56
-	2	2	1-2168083-0	SCR, SKT HD CAP, RoHS, M4 X 10	53
-	1	1	5018030-1	NUT, HEX, REG, RoHS, M3	52
-	1	1	811242-5	BUMPER, HOLD DOWN	51
-	1	1	690753-2	SPACER, TONKER	50
-	1	2	18023-9	SCR, SKT HD CAP M4 X 6.0	49
-	-	1	2119652-1	FEED CAM, PRE FEED	48
-	1	1	1803602-1	SCR, BHSC, RoHS (M8 X 25)	41
-	1	1	1752356-3	SUPPORT, TERMINAL	34
-	2	2	2079383-5	SCR, BHSC, RoHS (M4 X 20)	33
-	2	2	2-2844962-4	SPACER, CYLINDRICAL, STRIP GUIDE	30
-	1	1	2844992-1	ASSEMBLY, STRIP GUIDE	29
-	1	1	455888-3	SPACER, CRIMPER	28
-	1	1	1320928-2	STRIP GUIDE	24
-	1	1	2168083-2	SCR, SKT HD CAP, RoHS, M4 X 8.0	21
-	2	2	1-18028-2	WASHER, FLAT, REG M4	20
-	1	1	2119533-4	STRIPPER, SIDE FEED	19
△	-	1	2119806-1	INSERT, SHEAR	13
-	1	1	3-22280-3	SPRING, COMPRESSION	12
-	1	1	1-356885-4	STOP, SHEAR	11
△	-	1	2119805-1	SHEAR HOLDER, FRONT	10
△	-	1	1803095-6	FLOATING SHEAR, FRONT	9
△	1	1	2-1803056-0	ANVIL, COMBINATION	8
-	-	-	-	-	7
-	-	-	-	-	6
-	1	1	2119780-4	DEPRESSOR, SHEAR	5
-	1	1	238011-7	BLOCK, CRIMPER SPACER	4
△	1	1	1633966-6	CRIMPER, INSULATION O	3
-	1	1	455888-3	SPACER, CRIMPER	2
△	1	1	1-1803454-1	CRIMPER, WIRE	1

DIMENSIONS:		TOLERANCES UNLESS OTHERWISE SPECIFIED:		DWG: J.HOU 17SEP2014	
mm	0 PLC ±	1 PLC ±	2 PLC ±	CHK: Y.YIN 17SEP2014	TE Connectivity Harrisburg, PA 17105-3608
	3 PLC ±	4 PLC ±	ANGLES ±	APPV: H.GUO 17SEP2014	NAME: Ocean Side Feed Applicator
MATERIAL:	FINISH:	WEIGHT:	SCALE: 1:2	SIZE: A1	RESTRICTED TO: E
Customer Accessible Production Drawing			SHEET 3 OF 4	REV E	

LOC		DIST		REVISIONS			
A	66	P	LTM	DESCRIPTION	DATE	DMN	APVD
-	-	-	-	SEE SHEET 1	-	-	-

FEED TYPE MECHANICAL

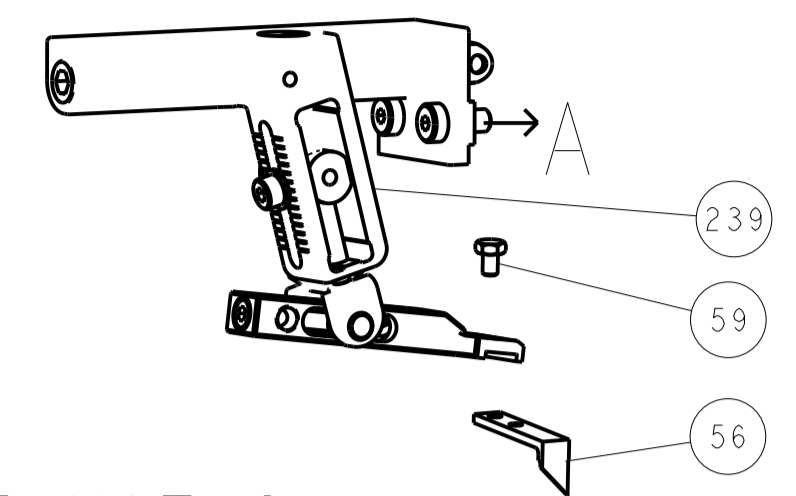

PNEUMATIC

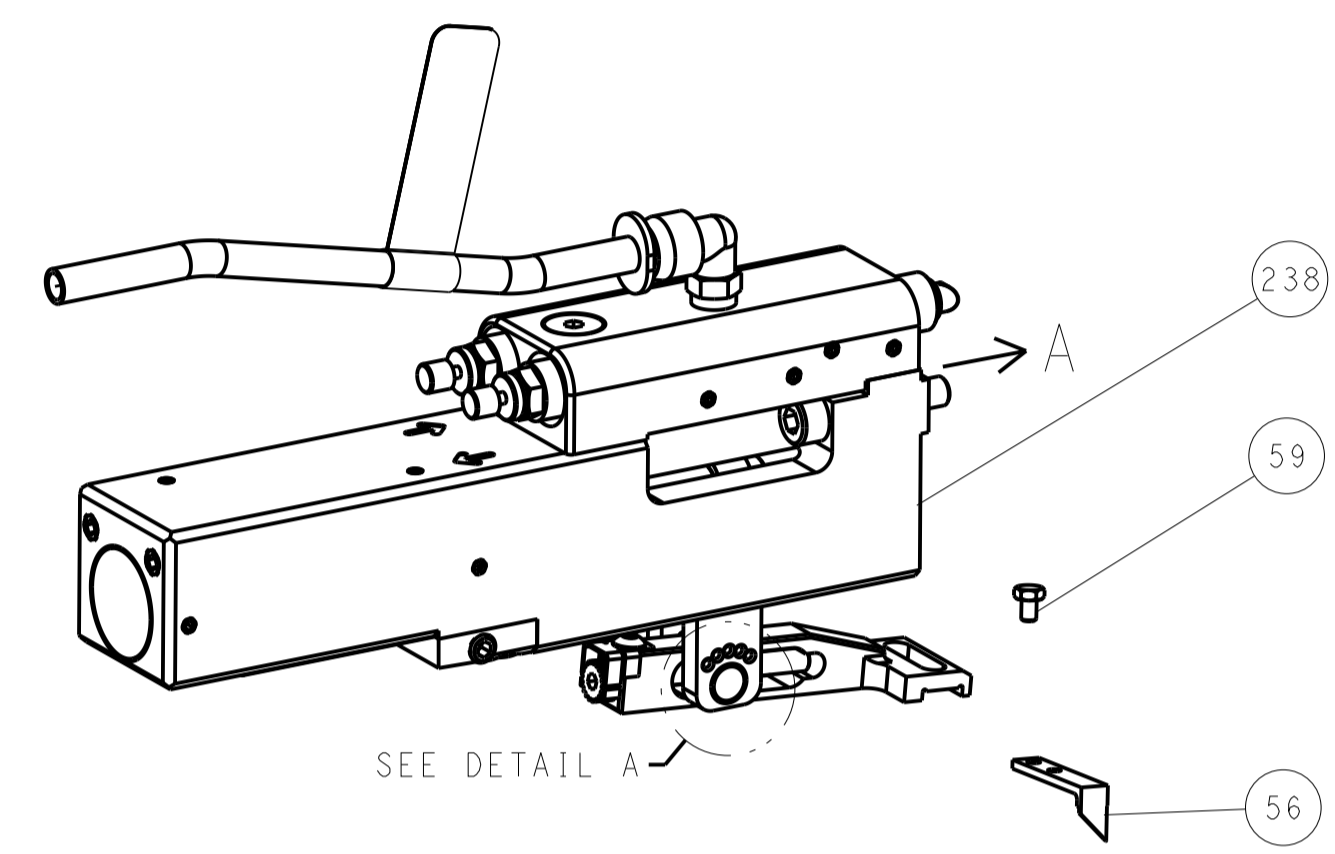

FEED SPRING SETTING POSITION (SHOWN FROM REAR SIDE)

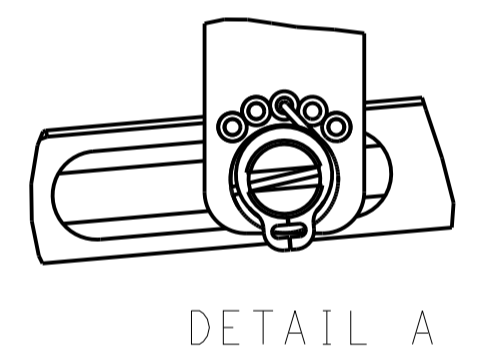

DETAIL A

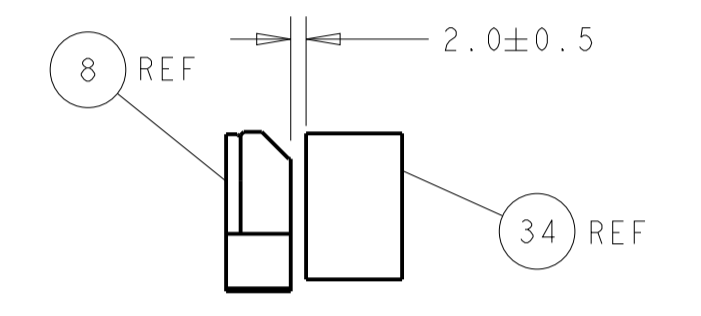
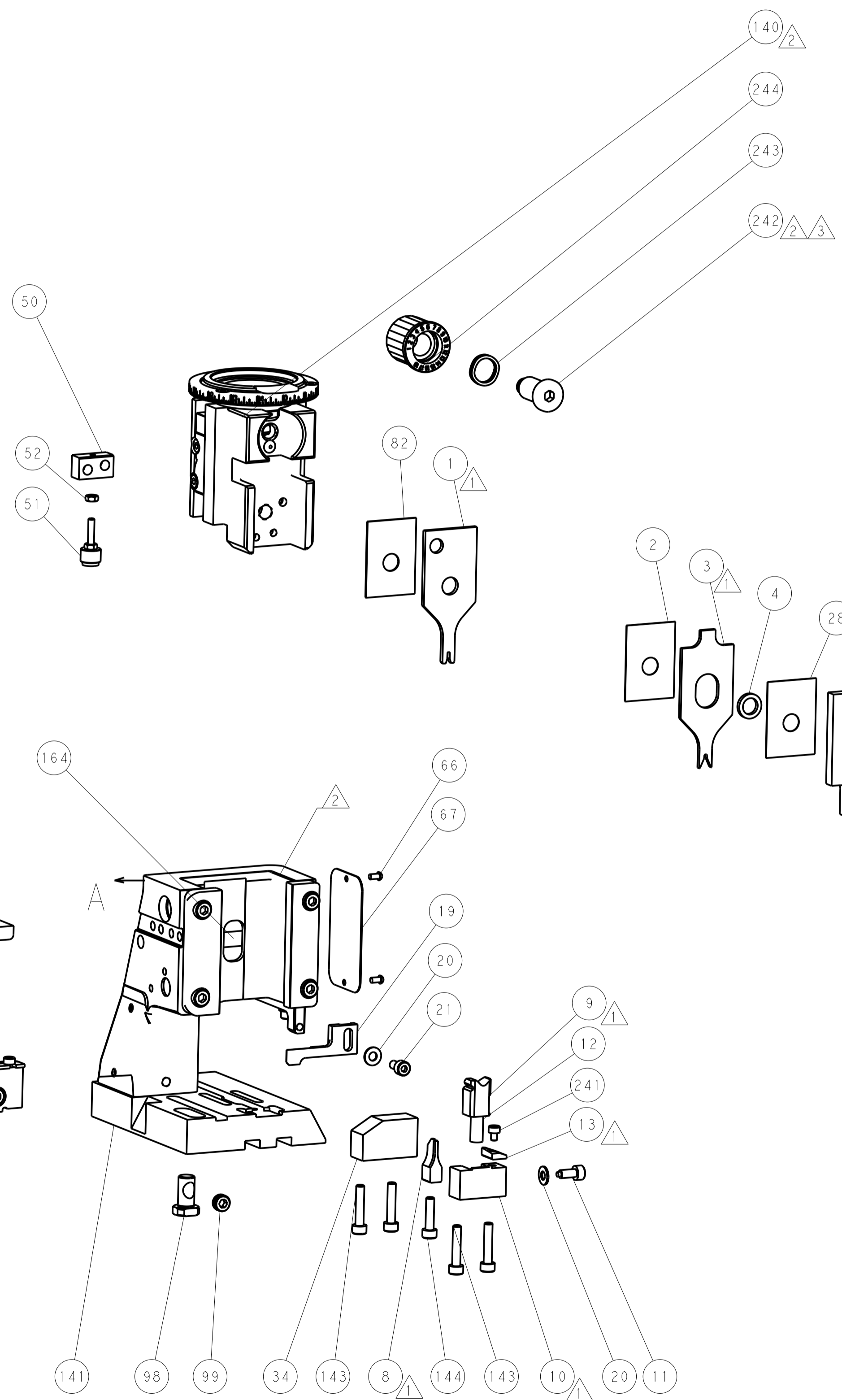
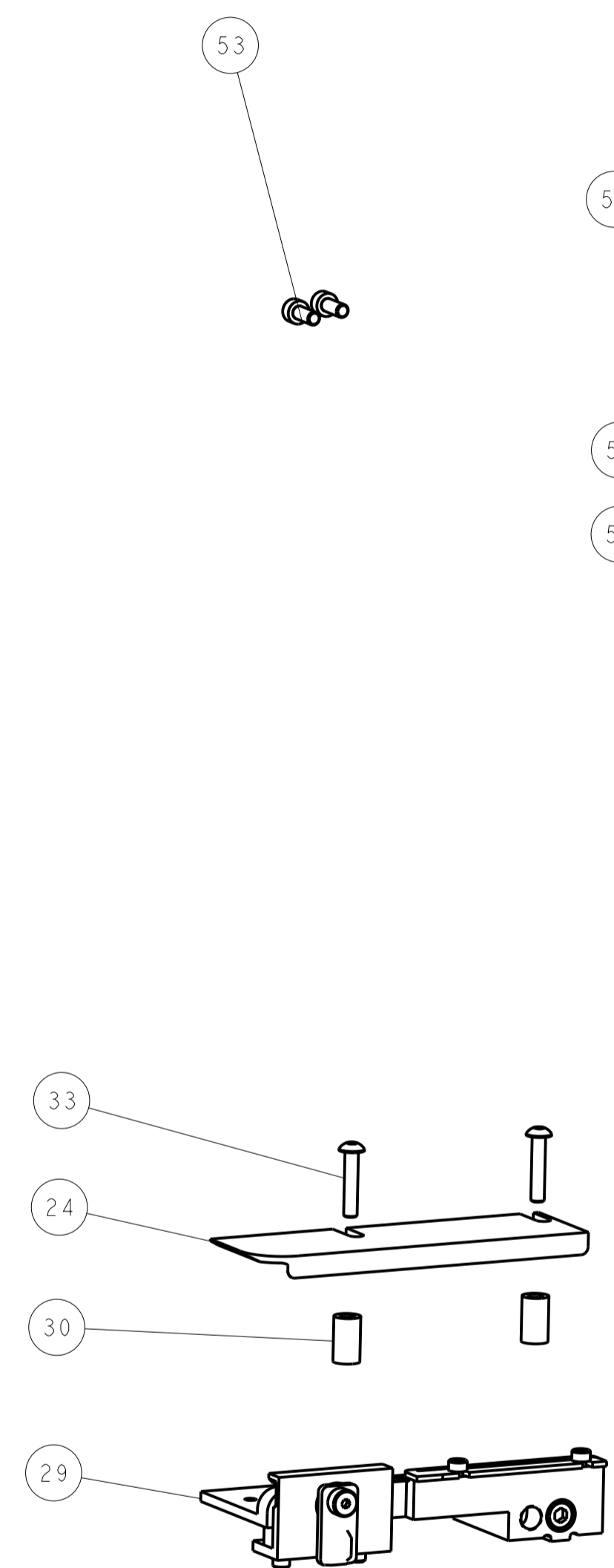

TERMINAL SUPPORT LOCATION

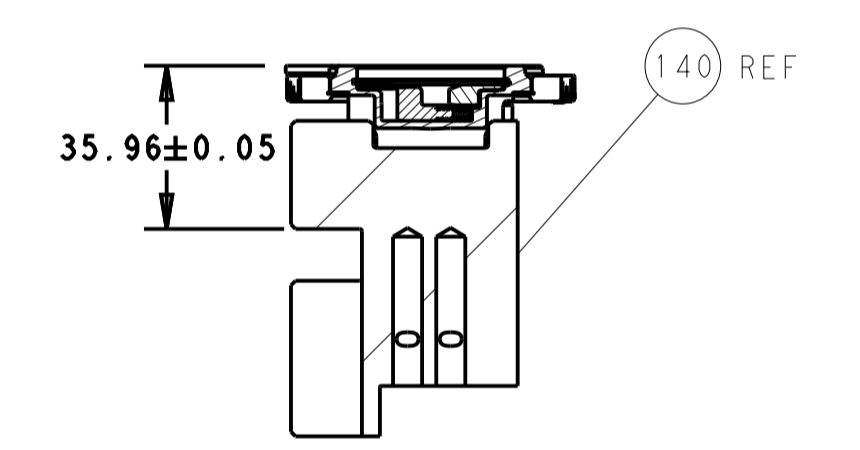

RAM SET-UP

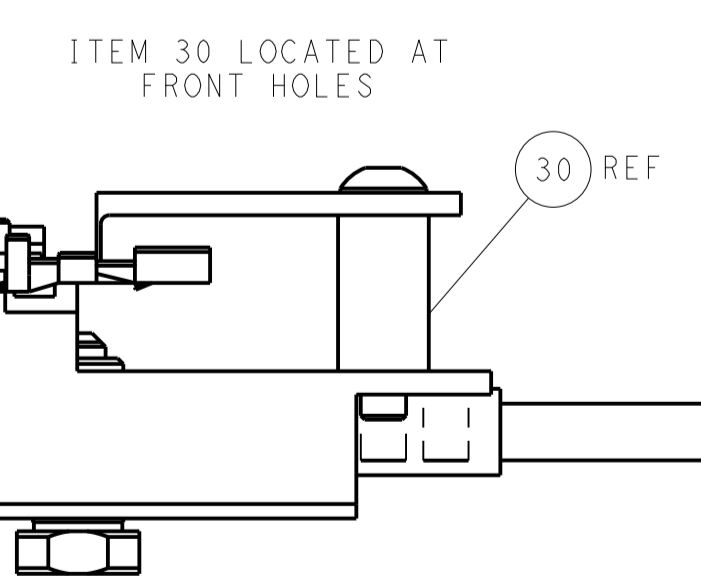

FEED TRACK POSITION GUIDE BY WIRE BARREL

CAM POSITIONS

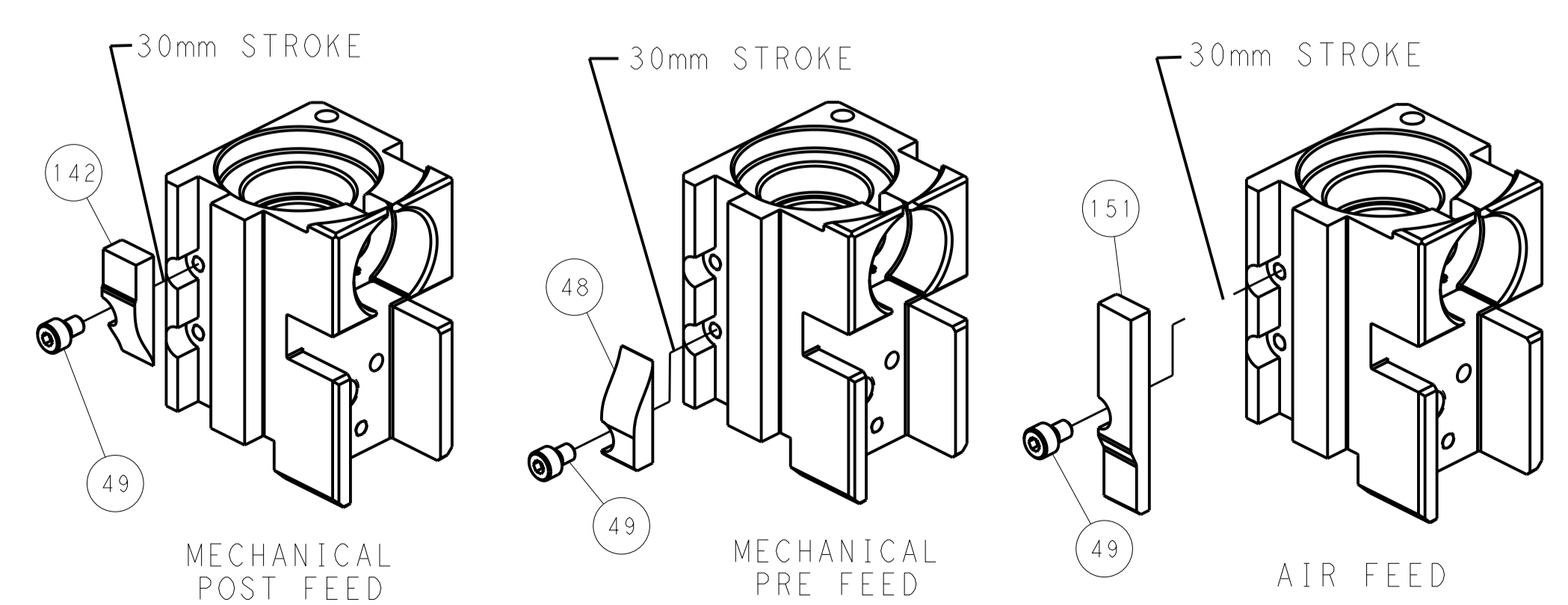

PACIFIC VERSION
 Shown on sheets 3 of 4 & 4 of 4
 (Atlantic version shown on sheets 1 of 4 & 2 of 4)

DIMENSIONS:		TOLERANCES UNLESS OTHERWISE SPECIFIED:		DWG: J.HOU 17SEP2014		REV: Y.YIN 17SEP2014		NAME: Ocean Side Feed Applicator	
mm	0 PLC	±		PRODUCT SPEC	APVD: H.GUO 17SEP2014	SIZE: A1	CAGE CODE: 00779	DRAWING NO: 2151084	RESTRICTED TO: -
	1 PLC	±		APPLICATION SPEC	WEIGHT: -	Customer Accessible Production Drawing		SCALE: 1:2	SHEET: 4 OF 4
	2 PLC	±							REV: E
	3 PLC	±							
	4 PLC	±							
	5 PLC	±							
	6 PLC	±							
	7 PLC	±							
	8 PLC	±							
	9 PLC	±							
	10 PLC	±							
	11 PLC	±							
	12 PLC	±							
	13 PLC	±							
	14 PLC	±							
	15 PLC	±							
	16 PLC	±							
	17 PLC	±							
	18 PLC	±							
	19 PLC	±							
	20 PLC	±							
	21 PLC	±							
	22 PLC	±							
	23 PLC	±							
	24 PLC	±							
	25 PLC	±							
	26 PLC	±							
	27 PLC	±							
	28 PLC	±							
	29 PLC	±							
	30 PLC	±							
	31 PLC	±							
	32 PLC	±							
	33 PLC	±							
	34 PLC	±							
	35 PLC	±							
	36 PLC	±							
	37 PLC	±							
	38 PLC	±							
	39 PLC	±							
	40 PLC	±							
	41 PLC	±							
	42 PLC	±							
	43 PLC	±							
	44 PLC	±							
	45 PLC	±							
	46 PLC	±							
	47 PLC	±							
	48 PLC	±							
	49 PLC	±							
	50 PLC	±							
	51 PLC	±							
	52 PLC	±							
	53 PLC	±							
	54 PLC	±							
	55 PLC	±							
	56 PLC	±							
	57 PLC	±							
	58 PLC	±							
	59 PLC	±							
	60 PLC	±							
	61 PLC	±							
	62 PLC	±							
	63 PLC	±							
	64 PLC	±							
	65 PLC	±							
	66 PLC	±							
	67 PLC	±							
	68 PLC	±							
	69 PLC	±							
	70 PLC	±							
	71 PLC	±							
	72 PLC	±							
	73 PLC	±							
	74 PLC	±							
	75 PLC	±							
	76 PLC	±							
	77 PLC	±							
	78 PLC	±							
	79 PLC	±							
	80 PLC	±							
	81 PLC	±							
	82 PLC	±							
	83 PLC	±							
	84 PLC	±							
	85 PLC	±							
	86 PLC	±							
	87 PLC	±							
	88 PLC	±							
	89 PLC	±							
	90 PLC	±							
	91 PLC	±							
	92 PLC	±							
	93 PLC	±							
	94 PLC	±							
	95 PLC	±							
	96 PLC	±							
	97 PLC	±							
	98 PLC	±							
	99 PLC	±							
	100 PLC	±							