

WIRING DIAGRAM

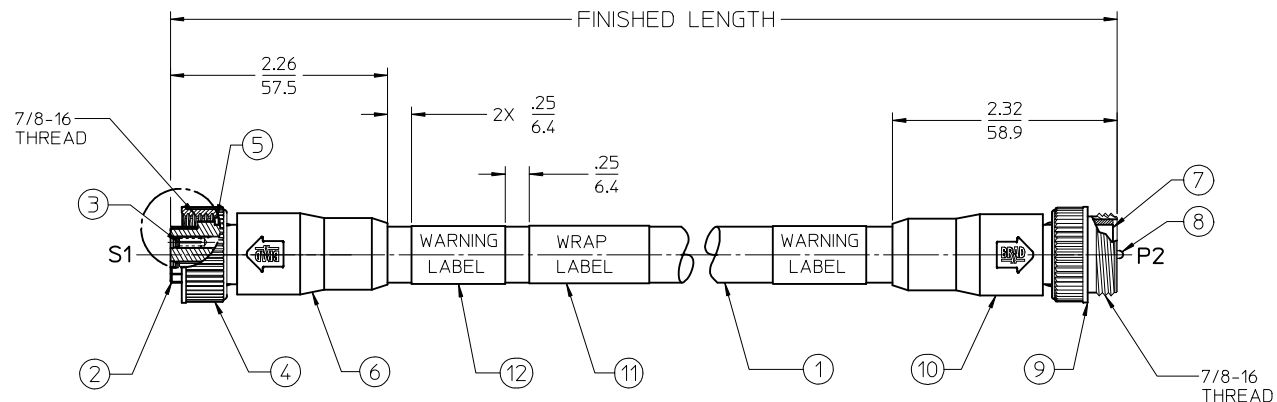

NOTES:

1. MATERIAL: SEE TABLE
2. FINISHES: SEE TABLE
3. WRAP LABEL IS MARKED WITH P/N, DATE CODE VOLTAGE & AMPERAGE
4. MATES WITH: MINI CHANGE 3 POLE RECEPTACLE (TRI-KEY)
5. ELECTRICAL DATA:  
 14AWG UL TYPE: TC-ER STRANDED CABLE  
 MAX VOLTAGE: 600V  
 MAX CURRENT: 15A  
 PROTECTION IP67 (WHEN MATED)  
 TEMPERATURE RANGE: -20°C TO 90°C
6. PACKAGING:  
 CABLE ASSEMBLIES ARE BAGGED SEPERATLY IN POLY BAGS WITH BAR CODE LABEL ATTACHED TO OUTSIDE OF BAG
7. ALL DIMS ARE FOR REFERENCE ULESS NOTED OTHERWISE

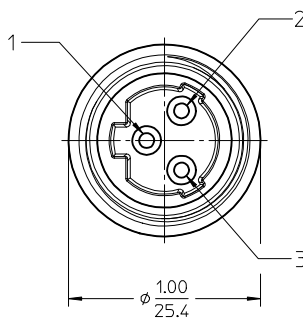

FEMALE FACE VIEW  
SCALE: 2X

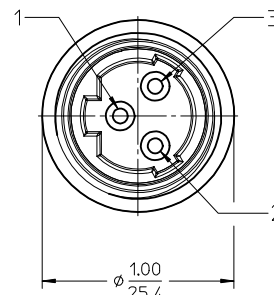

MALE FACE VIEW  
SCALE: 2X

PART NUMBER LEGEND

113130K20MXXX

MC 3P FEM STRAIGHT TO MALE STRAIGHT (EXT THD), TRI KEY  
 FINISHED LENGTH:  
 M001= .1M  
 M010= 1.0M  
 M100= 10.0M  
 CABLE TYPE: 14 AWG TC ER, BLACK

12	2	WARNING LABEL	VINYL	ORANGE/BLACK
11	1	WRAP LABEL	VINYL	BLACK/YELLOW
10	1	MALE OVERMOLD	PVC	BLACK
9	1	MALE COUPLING NUT	ZINC ALLOY	BLACK
8	3	CONTACT PIN	Cu ALLOY	GOLD PLATE
7	1	MALE INSERT	PVC	BLACK
6	1	FEMALE OVERMOLD	PVC	BLACK
5	1	FRICITION RING	NYLON	WHITE
4	1	FEMALE COUPLING NUT	ZINC ALLOY	BLACK
3	3	CONTACT SOCKET	Cu ALLOY	GOLD PLATE
2	1	FEMALE INSERT	PVC	BLACK
1	SEE NOTE 5	CABLE	TPE	BLACK
ITEM	QTY	DESCRIPTION	MATERIAL	FINISH

RELEASED	EC NO: IPG2017-0147	2016/08/08
DRWINRSTONE	2016/11/17	
CHKD:M ZIEL INSK I	2016/11/17	
APPR: BWOODMAN	2016/11/30	
DESCRIPTION		

QUALITY SYMBOLS	GENERAL TOLERANCES (UNLESS SPECIFIED)
▽=0	mm INCH
▽=0	4 PLACES ± --- ± ---
	3 PLACES ± --- ± ---
	2 PLACES ± --- ± .01
	1 PLACE ± 0.3 ± ---
	0 PLACE ± --- ± ---
	ANGULAR ± 1 °
	DRAFT WHERE APPLICABLE MUST REMAIN WITHIN DIMENSIONS

DIMENSION STYLE	SCALE	DESIGN UNITS	THIRD ANGLE PROJECTION
IN/MM	1:1	INCH	
DRAWN BY	DATE	TITLE	
RSTONE	2016/08/08	MINI-CHANGE CABLE ASSY	
CHECKED BY	DATE	FEM STR TO MALE STR	
		EXT THD, TRI KEY, 14 AWG	
APPROVED BY	DATE		
BWOODMAN	2016/11/30		
MATERIAL NO.	DOCUMENT NO.		
-	SD-130062-038		

SIZE	THIS DRAWING CONTAINS INFORMATION THAT IS PROPRIETARY TO MOLEX INCORPORATED AND SHOULD NOT BE USED WITHOUT WRITTEN PERMISSION	
C		