

Description	Material	Finish
Body	Brass	Nickel
Socket	Brass	Gold
Insulation	PTFE	N/A
Crimp Ring	Brass	Nickel
O Ring	SI Rubber	Rubber
Washer	Brass	Nickel
Nut	Brass	Nickel

REVISIONS			
REV	DESCRIPTION	DATE	APPV
B	Added New Title Block	12-JUL-12	SAH

NUT

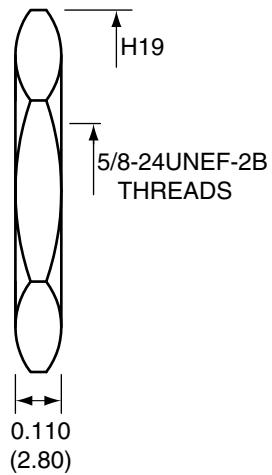

WASHER

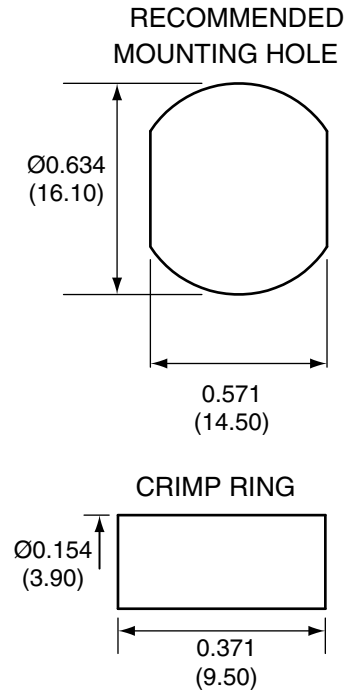
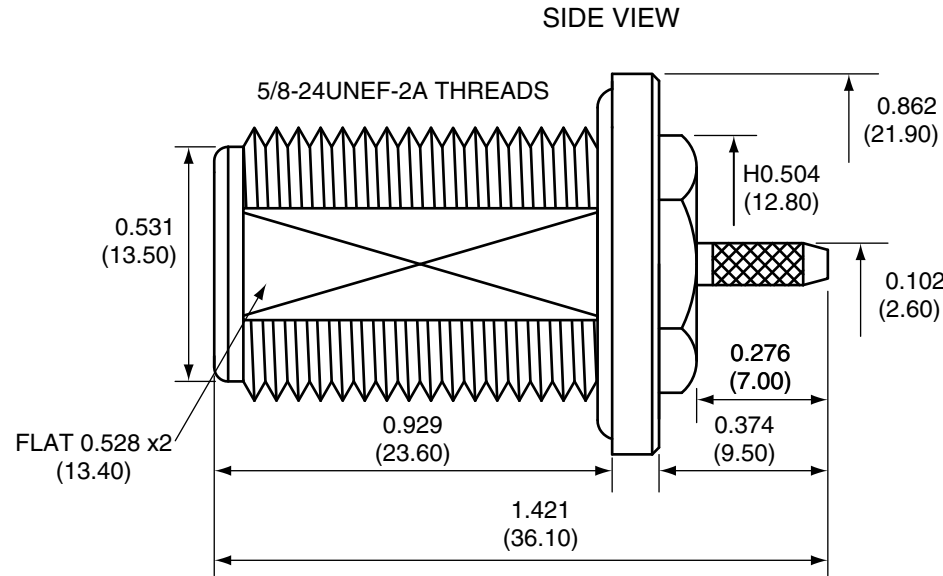
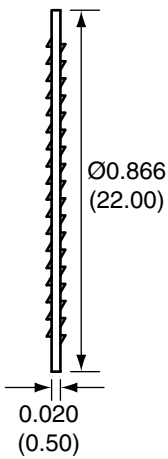

RECOMMENDED CABLE STRIPPING DIMENSIONS

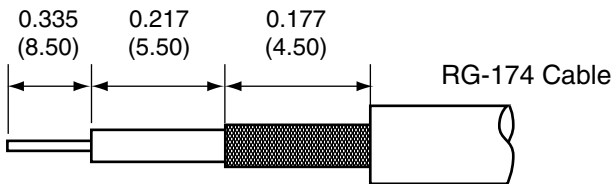

CONN005 ASSEMBLY INSTRUCTIONS

1. Insert the cable center conductor and insulation into the base
2. Solder the socket to the center conductor.
3. Wrap the braid around the tail of the body and crimp the ring with a hex crimp tool.
4. Put the socket through the insulator.
5. Screw the base into the top.

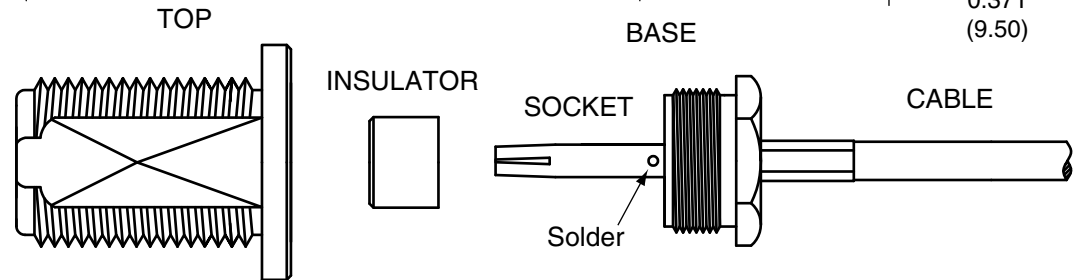

NOTES: (UNLESS OTHERWISE SPECIFIED)

1. ALL DIMENSIONS ARE IN INCHES [mm].
2. DIMENSIONS APPLY AFTER FINISHING.
3. MANUFACTURE TO BE COMPLIANT WITH EU RoHS DIRECTIVE.
4. SAFETY BREAK ALL SHARP CORNERS AND EDGES .02 MAXIMUM.

WARNING: THIS DRAWING CONTAINS PROPRIETARY INFORMATION THAT IS THE SOLE PROPERTY OF LINX TECHNOLOGIES, AND SHALL BE TREATED AS SUCH. NO DISCLOSURE OR REPRODUCTION OF THIS DOCUMENT IS PERMITTED, IN WHOLE OR IN PART, WITHOUT THE EXPRESS WRITTEN PERMISSION OF LINX TECHNOLOGIES OR ITS DESIGNATED AGENTS.

MATERIAL:	TOLERANCES: .020 [0.50]-.200 [5.00]= ±.008 [0.20] .200 [5.00]-1.200 [30.00]= ±.016 [0.40] 1.20 [30.0]-4.75 [120.0]= ±.024 [0.60] 4.75 [120.0]-12.40 [315.0]= ±.040 [1.0]	PROJECTION:
FINISH:	DRAWN: B.MURPHY ENGR: S.HOGAN	DT: 12-JUL-12 DT: 12-JUL-12

Linx		159 ORT LANE MERLIN, OR 97532	
TITLE: N FEMALE BULKHEAD MOUNT CABLE END CRIMP FOR RG174 CABLE			
SIZE A	DWG. NO. CONN005	REV B	
SCALE: 2:1	DO NOT SCALE DRAWING	SHEET 1 OF 1	