

SW2010

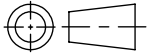

Revision level		Revision Record	Changed	Date	Approved	Date
Drawing	Part					
03	-	SEE ECN# 012051	AAC	01/26/2012	KAC	03/07/2012

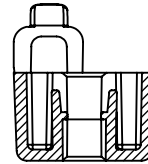
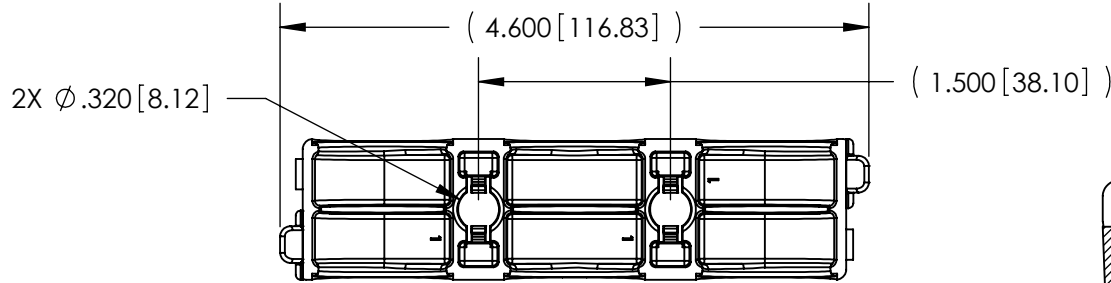

SECTION A-A

ASSEMBLED

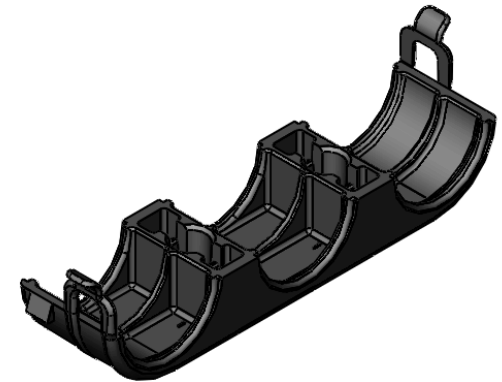
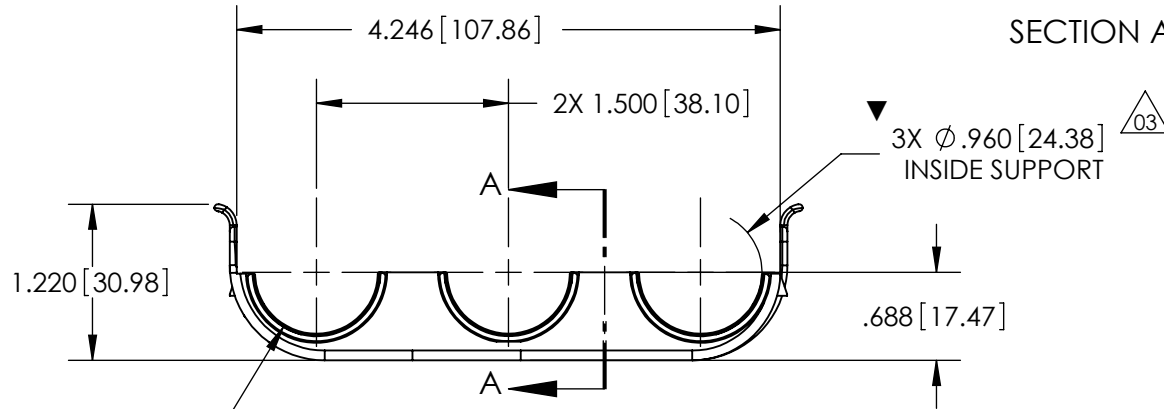
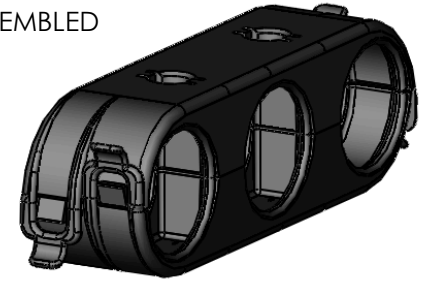

3X Ø 1.000 [25.40]
OUTER SUPPORT

1.100 [27.94]

= CRITICAL DIMENSION

Material
PA66HIRGF13

Units inches
Dimension without tolerances details to:
.xxxx = ±.0005
.xxx = ±.005
.xx = ±.01
.x = ±.03
None = ±.06
∠ = ±0.5°

The copyright of this drawing is reserved by HellermannTyton. It is issued on condition that it is not reproduced, copied, or disclosed to a third party, either wholly or in part, without the consent of HellermannTyton.

Drawn	MHT	01/13/2012
Approved	AAC	01/26/2012
HellermannTyton		
North America Email: corp@htamericas.com Web: www.hellermann.tyton.com		

Article/Type-No	HC3A
Title	HOSE CLAMP TRIPLE
Drawing-No	11-0740-005-CSU
Production : Phase	

Scale	2:3
Project Number	PRP11-0740
Format	AH
Sheet	1/1