

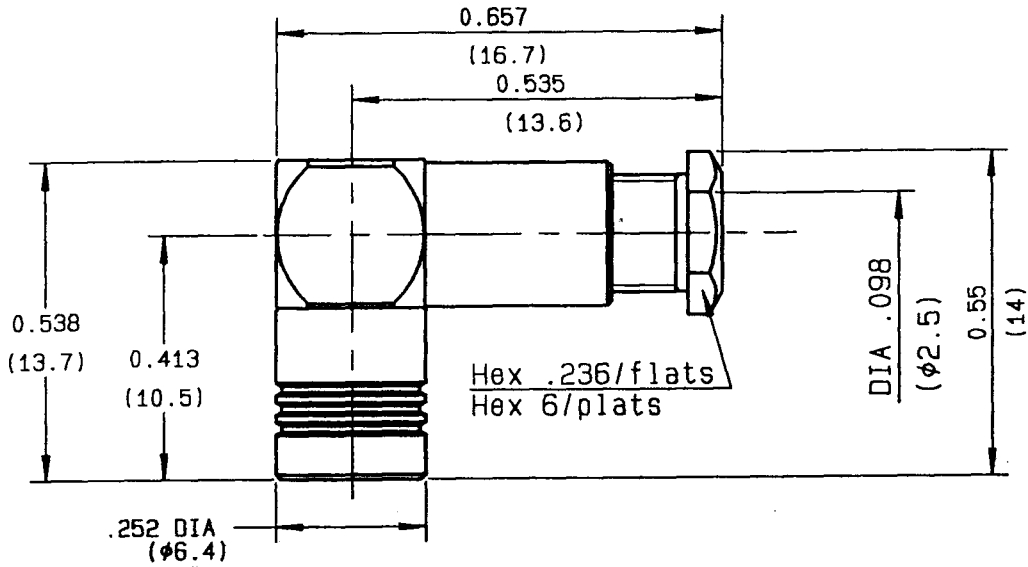

**RIGHT ANGLE PLUG CLAMP TYPE FOR
CABLE 2.2/50 DOUBLE BRAIDED**

R114.163.420
SERIES **SMB**



NOMINAL IMPEDANCE	50 Ω	CABLES : TS 2619	
FREQUENCY RANGE	0-4 GHz		
TEMPERATURE RATING	-65/+165 °C		
V.S.W.R	1.45 + .06 x F(GHz)Maxi		
RF INSERTION LOSS	0.6 \sqrt{F} (GHz) dB Maxi		
VOLTAGE RATING	335 V _{eff} Maxi		
DIELECTRIC WITHSTANDING VOLTAGE	1000 V _{eff} Mini		
INSULATION RESISTANCE	1000 M Ω Mini	OTHERS CHARACTERISTICS	
HERMETIC SEAL	NA Atm.cm ³ /s	CABLE RETENTION	TBD N Mini R-A-S
LEAKAGE (pressurized only)	NA MPa	CENTER CONTACT RETENTION	
MECHANICAL DURABILITY	Cycles	Axial force - mating end	10 N Mini
WEIGHT	gr	Axial force - opposite end	10 N Mini
SPECIFICATION		Torque	NA cm.N Mini
		RECOMMENDED TORQUES	
		Mating	NA cm.N
		Panel nut	NA cm.N
		Clamp nut	40 cm.N

CONNECTOR PARTS	MATERIALS	FINISH	(all values are given in micrometers)
BODY	BRASS	GOLD 0.2 OVER NICKEL 2	
OUTER CONTACT	BERYLLIUM COPPER	GOLD 0.5 OVER NICKEL 2	
CENTER CONTACT	BERYLLIUM COPPER	GOLD 1.3 OVER NICKEL 2	
INSULATOR	PTFE	-	
GASKET		-	
OTHERS PIECES			

ISSUE	CREATION DATE	FILE PART-NUMBER	
9626C	27-MAY-93	91-0019-002	

The information given here is subject to change without notice. Design changes may be in order to improve the product.

Connect to the future



R114.163.420

ISSUE 9850C00 SERIES SMB

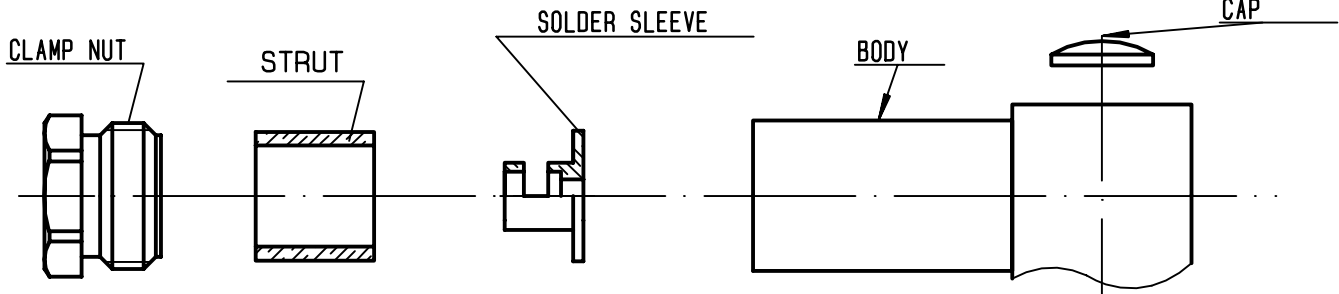

1

Slide the clamp nut ,the strut onto the cable

Strip the cable .
Dip tinned centre conductor of cable .

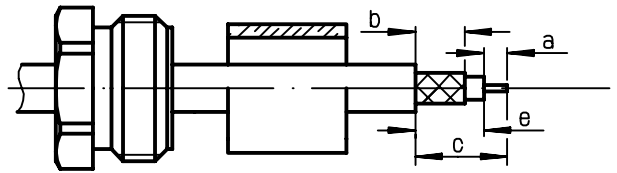

Stripping	a	b	c	d	e
inch	0.059	0.118	0.307	0	0.248
mm	1.5	3	7.8		6.3

2

Solder the solder sleeve onto the braid .

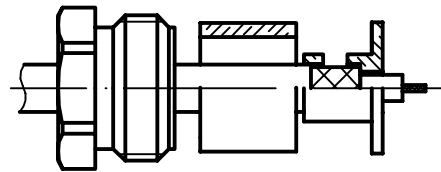

3

Screw sub-assembly into the connector body .
(recommended coupling torque 3.53 in.lb)
Ref. wrench .236/flats : R282 318 000

Solder center contact

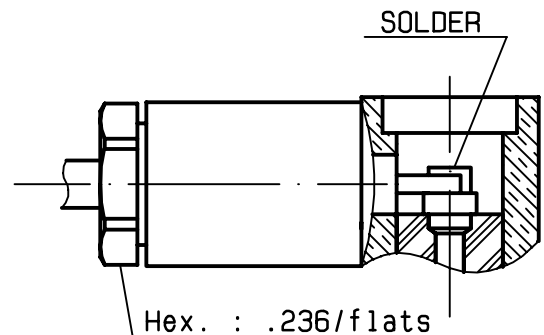

4

Press cap flush or slightly below surface of body assembly .

-

-

-

