

REV. L

.0900 [2.287]  
(MIN. TAIL)

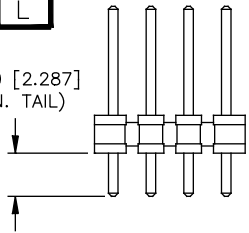

IN PROCESS 1

.0900 [2.287]  
.007 MAX [.178]

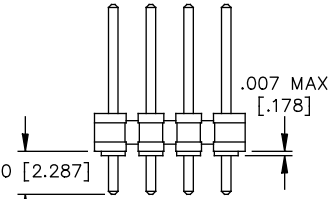

IN PROCESS 2

RE-PRESS TO  
DESIRED TAIL (.300 MAX)

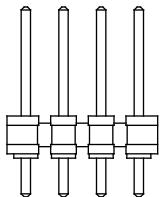

IN PROCESS 3

MOUNT  
STACKER  
BODY

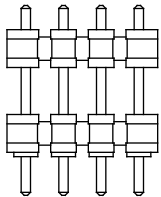

IN PROCESS 4

UNLESS OTHERWISE NOTED  
DIMENSIONS ARE IN INCHES  
TOLERANCES ARE:  
ONE PLACE DECIMALS ±.1[2.5] THREE PLACE DECIMALS ±.005 [.13]  
TWO PLACE DECIMALS ±.01[.25] FOUR PLACE DECIMALS ±.0020[.05]

ANGLES  
± 2°

TITLE: 2mm  
TERMINAL STRIP  
ASSEMBLY

DWG NO:  
YTW-XX-XX-XXX-X-XXX-XXX-XXX-XX  
SHEET 3 OF 3

FIG. 2  
\*\* -MW: METAL WASHER  
(ONE PER POSITION)  
(30 POS MAX)

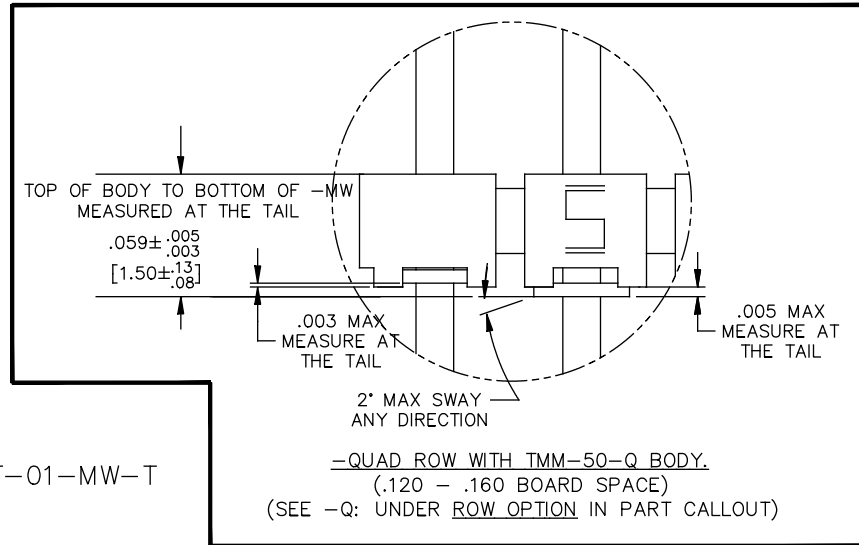
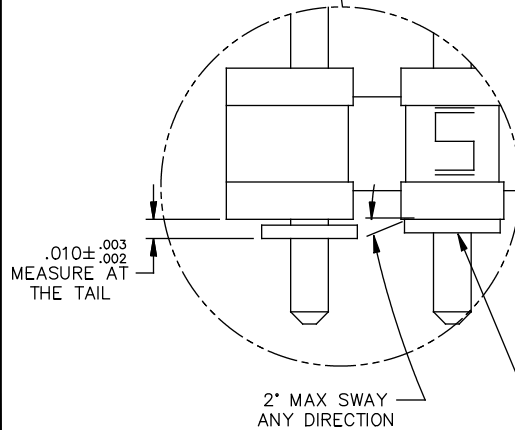
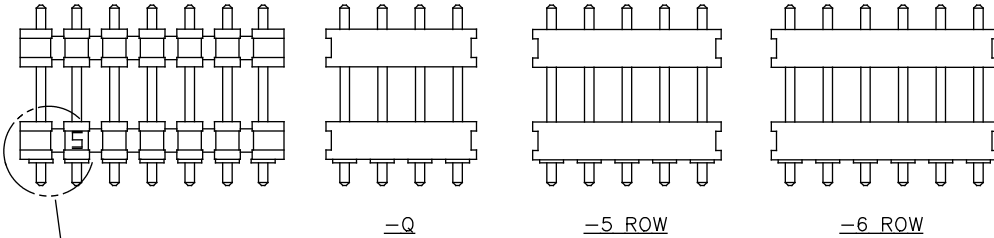

SQT-01-MW-T

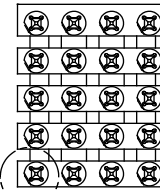
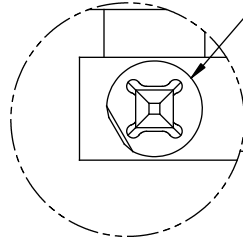

-Q

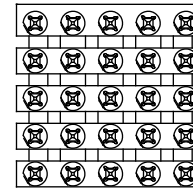

-5 ROW

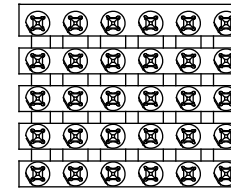

-6 ROW

\*\* - MW OPTION, DO NOT DESIGN IN. SAMTEC WILL  
ONLY SUPPORT EXISTING BUSINESS 2/11/02.

PROPRIETARY NOTE  
THIS DOCUMENT CONTAINS CONFIDENTIAL AND PROPRIETARY INFORMATION AND ALL DESIGN, MANUFACTURING, REPRODUCTION, USE, PATENT RIGHTS AND SALES RIGHTS ARE EXPRESSLY RESERVED BY SAMTEC, INC. THIS DOCUMENT SHALL NOT BE DISCLOSED, IN WHOLE OR PART, TO ANY UNAUTHORIZED PERSON OR ENTITY NOR REPRODUCED, TRANSMITTED OR INCORPORATED IN ANY OTHER PRODUCT IN ANY MANNER WITHOUT THE EXPRESS WRITTEN CONSENT OF SAMTEC, INC.

EXISPROD\ASSEMBLY\2MM  
YTWASM3  
**samtec**

520 PARK EAST BLVD. NEW ALBANY, INDIANA 47150  
PHONE (812) 944-6733 P.O. BOX 1147  
CODE 55322

MADE BY:  
BRYANT 02/09/99

YTW-XX-XX-XXX-X-XXX-XXX-XXX-XX  
SHEET 3 OF 3

PLOT SCALE 1=-2