

THIS DRAWING IS UNPUBLISHED. RELEASED FOR PUBLICATION
 © COPYRIGHT - By - ALL RIGHTS RESERVED.

LOC		DIST		REVISIONS			
P	LTR	DESCRIPTION		DATE	DWN	APVD	
AF	50	C2	ECR-15-005665	10AUG2015	BDA	PKS	

- 1 CONTINUOUS STRIP ON REELS WITH TERMINALS LOCATED ON 8.38±0.08 [.330±.003] CENTERS.
- 2 SLOT TERMINATES A SINGLE MAGNET WIRE ONLY. COPPER RANGE: 1.45-1.29mm [#15-#16] AWG. ALUMINUM RANGE: 1.37-1.54mm [#15.5-#14.5] AWG. ALUMINUM WIRE RANGE APPLIES FOR POST-TIN PLATED VERSIONS ONLY.
- 3 AFTER INSERTION INTO PLASTIC HOLDER TAB PORTION MUST BE BENT OVER 45° TO 90° OR POTTED-IN TO PREVENT PULL-OUT WHEN MATING RECEPTACLE IS DISCONNECTED.
- 4 TIN PLATE

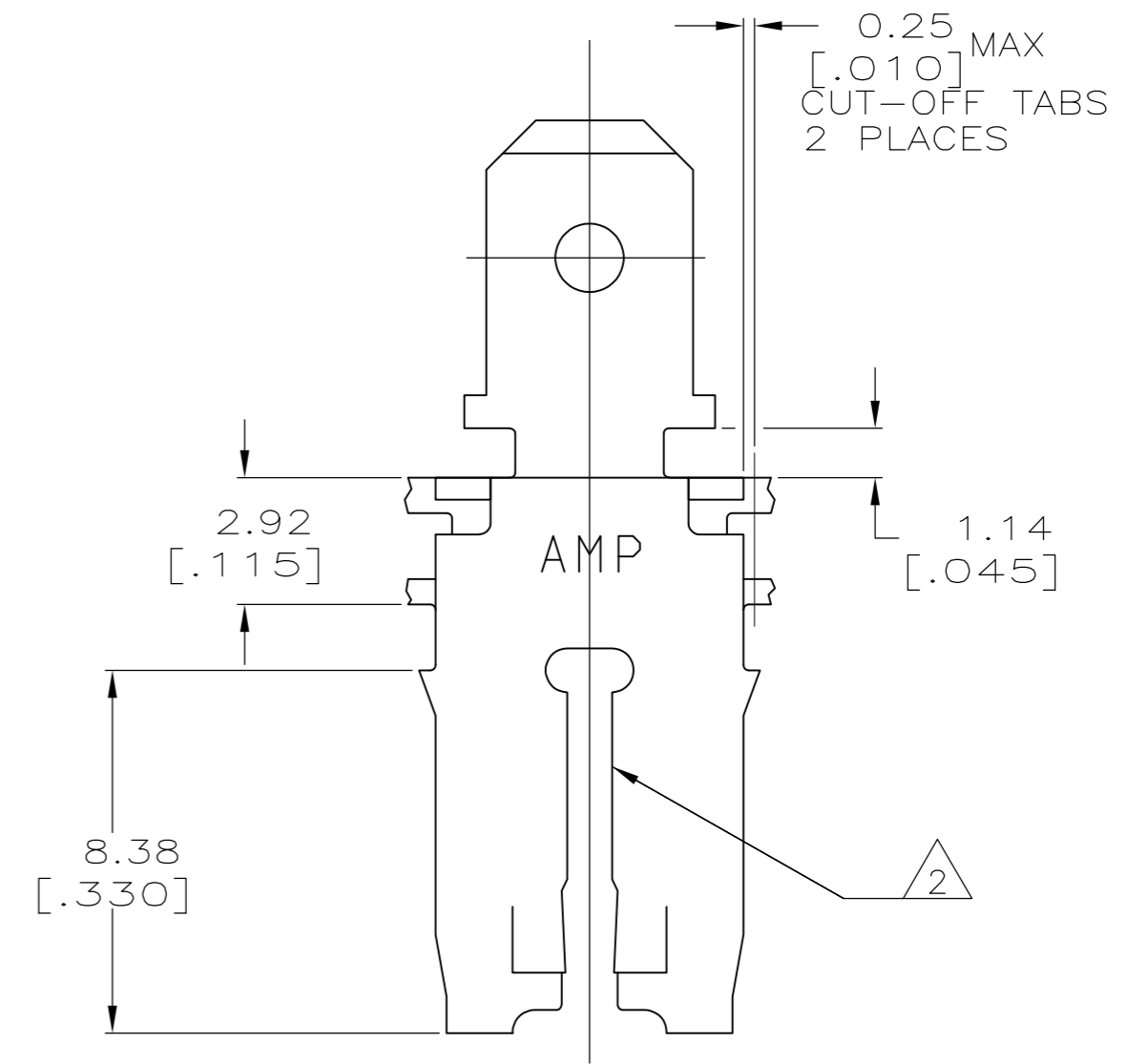
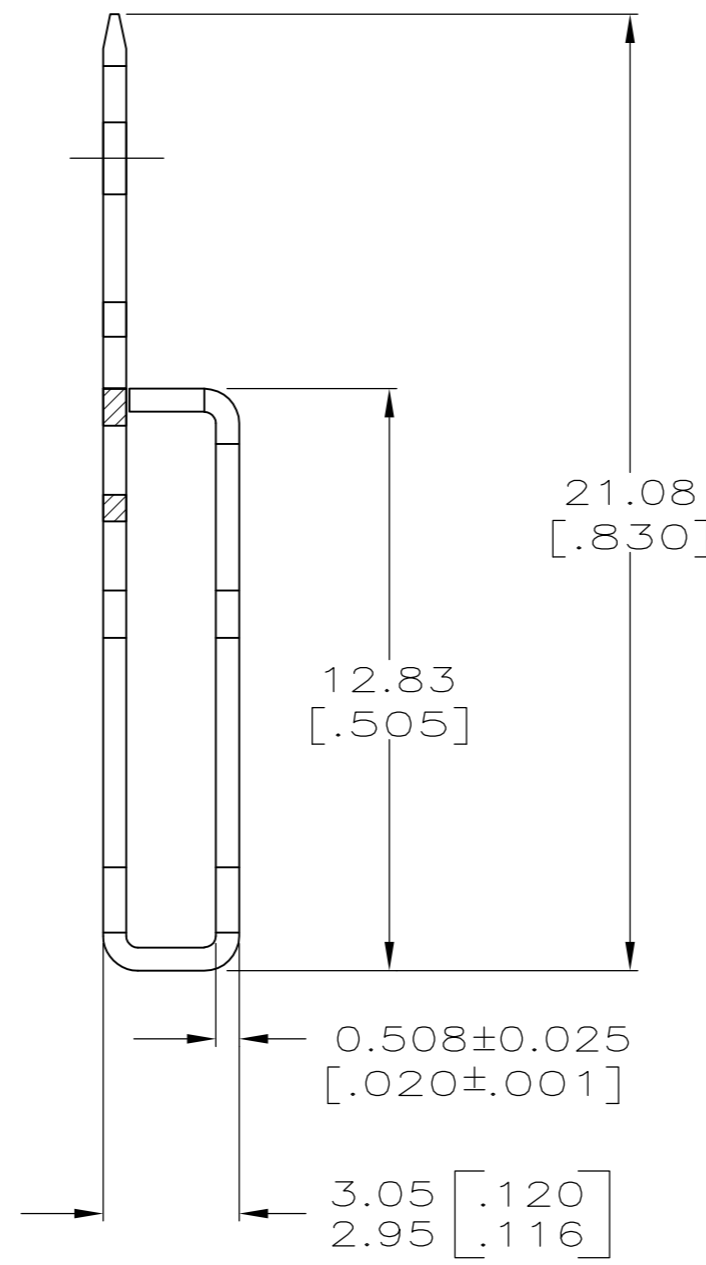
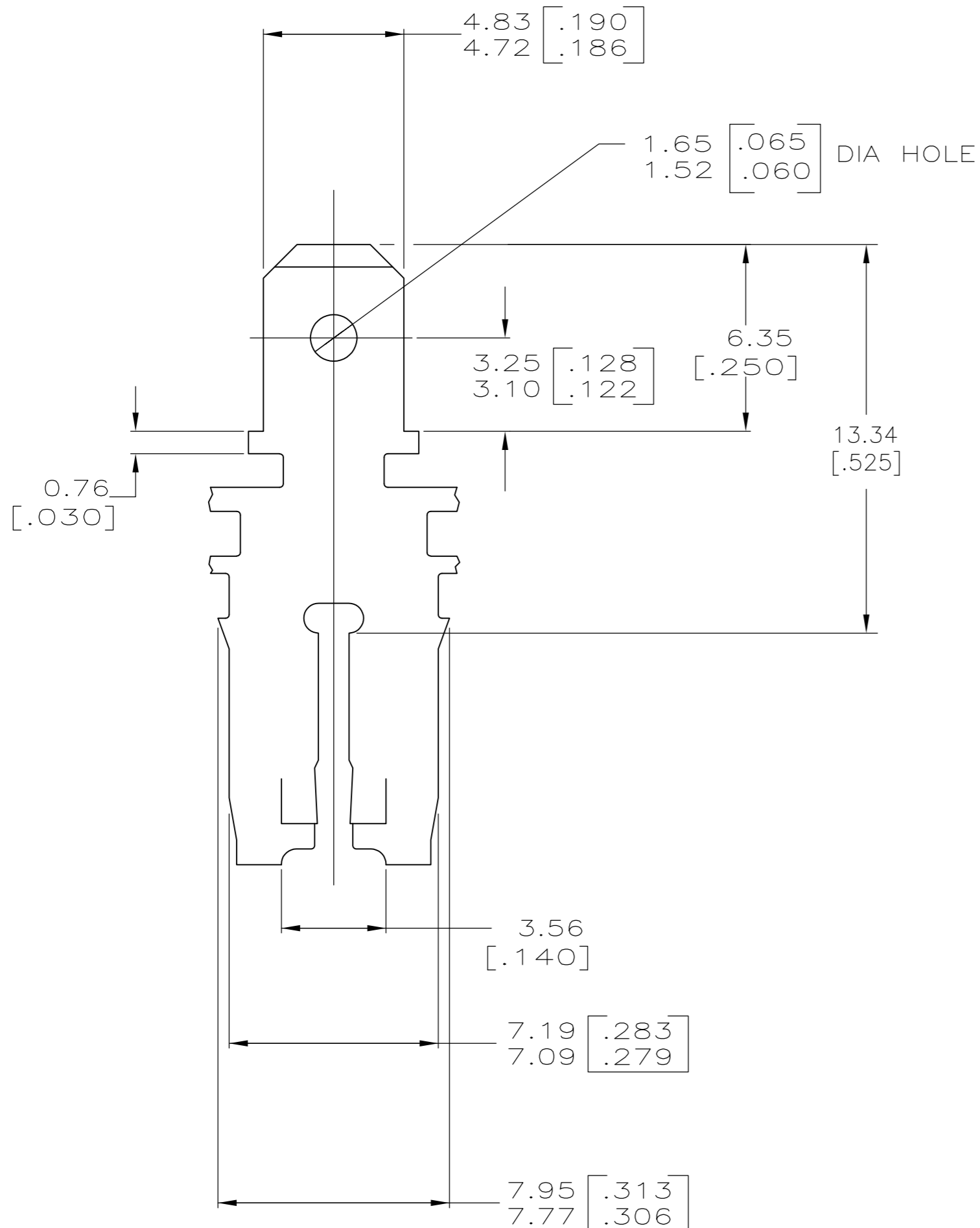
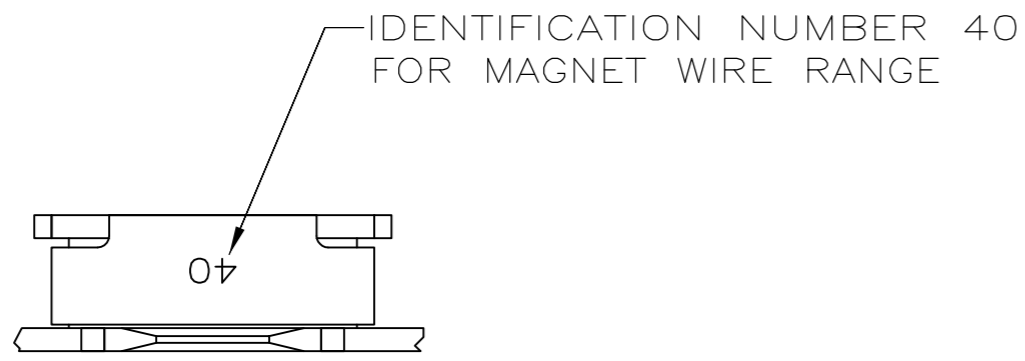

63666-1
PART NO.

THIS DRAWING IS A CONTROLLED DOCUMENT.		DWN MICHAEL S. FEHER 8/20/92		
DIMENSIONS: mm [INCHES]		CHK JEFF R. RUTH 8/21/92		
TOLERANCES UNLESS OTHERWISE SPECIFIED:		APVD NELSON E. NEFF 8/28/92	NAME TAB, 4.75 [.187] FASTON™, MAG-MATE™	
0 PLC ± -	1 PLC ± -	PRODUCT SPEC 108-2012	SIZE A2	CAGE CODE 00779
2 PLC ± 0.25 [.010]	3 PLC ± -	APPLICATION SPEC 114-2066	DRAWING NO 63666	RESTRICTED TO -
4 PLC ± -	ANGLES ± -	MATERIAL BRASS	WEIGHT -	SCALE 6:1
FINISH -4		CUSTOMER DRAWING		SHEET 1 OF 1
				REV C2