

RECOMMENDED SOLDER PAD DESIGN

PART NUMBER W/CAP IN TUBE	CKT. SIZE	DIM. A	DIM. B
87340-04*5	4	4.00	2.00
87340-06*5	6	6.00	4.00
87340-08*5	8	8.00	6.00
87340-10*5	10	10.00	8.00
87340-12*5	12	12.00	10.00
87340-14*5	14	14.00	12.00
87340-16*5	16	16.00	14.00
87340-18*5	18	18.00	16.00
87340-20*5	20	20.00	18.00

PART NO. LEGEND
 87340- * * * *
 ———— PACKAGING
 5 - TUBE
 6 - T&R
 ———— PLATING SEE NOTE 3
 ———— CIRCUIT SIZE

NOTES:

- FOR ILLUSTRATION PURPOSES, DRAWING SHOWS PART WITH 12 CIRCUIT SIZE.
- MATERIAL:
HOUSING: LCP GLASS FILLED, UL 94V-0
SUITABLE FOR SURFACE-MOUNT SOLDERING PROCESS.
COLOR BLACK
TERMINAL: PHOSPHOR BRONZE ALLOY.
3. PLATING- 9 : 0.38µm MINIMUM GOLD PLATE AT CONTACT AREA, AND 1.90µm MINIMUM TIN PLATE AT P.C TAIL AREA, BOTH OVER 1.27µm MINIMUM NICKEL OVERALL.
3 : 0.05-0.25µm GOLD PLATE AT CONTACT AREA, AND 1.90µm MINIMUM TIN PLATE AT P.C TAIL AREA, BOTH OVER 1.27µm MINIMUM NICKEL OVERALL.
4. COPLANARITY OF P.C TAIL TO BE MEASURED BY RESTING THE PART ON A FLAT GAGE SURFACE.
5. THIS AREA OF PART TO BE HEAT-STAKED TO RETAIN CONTACTS.
6. POSITION OF CAP TO BE LOCATED AT CENTER OF DIMENSION "A" REGARDLESS OF CIRCUIT SIZE.
7. PRODUCT SPECIFICATION PS-87340 APPLIES.
8. PART TO BE PACKAGED IN TAPE-&-REEL. SEE SHEET 2 FOR PACKAGING DETAILS.
9. CONTACT FACTORY FOR PARTS AVAILABILITY.

SYMBOLS	THIS DRAWING CONTAINS INFORMATION THAT IS PROPRIETARY TO MOLEX ELECTRONIC TECHNOLOGIES, LLC AND SHOULD NOT BE USED WITHOUT WRITTEN PERMISSION		CURRENT REV DESC:		molex
	DIMENSION UNITS	SCALE			
▽ = 0	mm	NTS			PRODUCT CUSTOMER DRAWING
▽ = 0	GENERAL TOLERANCES (UNLESS SPECIFIED)				
▽ = 0		MM	INCH	EC NO: 740811	DOCUMENT NUMBER
▽ = 0	4 PLACES ±			DRWN: DANUSA 2023/02/13	
▽ = 0	3 PLACES ±			CHK'D: SUAIFR 2023/03/02	DOC TYPE
▽ = 0	2 PLACES ±	0.2		APPR: MRAMAKRISHNA 2023/03/03	DOC PART
▽ = 0	1 PLACE ±			INITIAL REVISION:	REVISION
▽ = 0	0 PLACES ±			DRWN: JWAN 1995/01/25	
▽ = 0	ANGULAR TOL ±	3.0°		APPR: RWONG 1995/01/25	
▽ = 0	DRAFT WHERE APPLICABLE MUST REMAIN WITHIN DIMENSIONS	THIRD ANGLE PROJECTION		DRAWING	SERIES
▽ = 0		A3-SIZE		87340	MATERIAL NUMBER
		SEE TABLE		GENERAL MARKET	SHEET NUMBER
		1 OF 2			

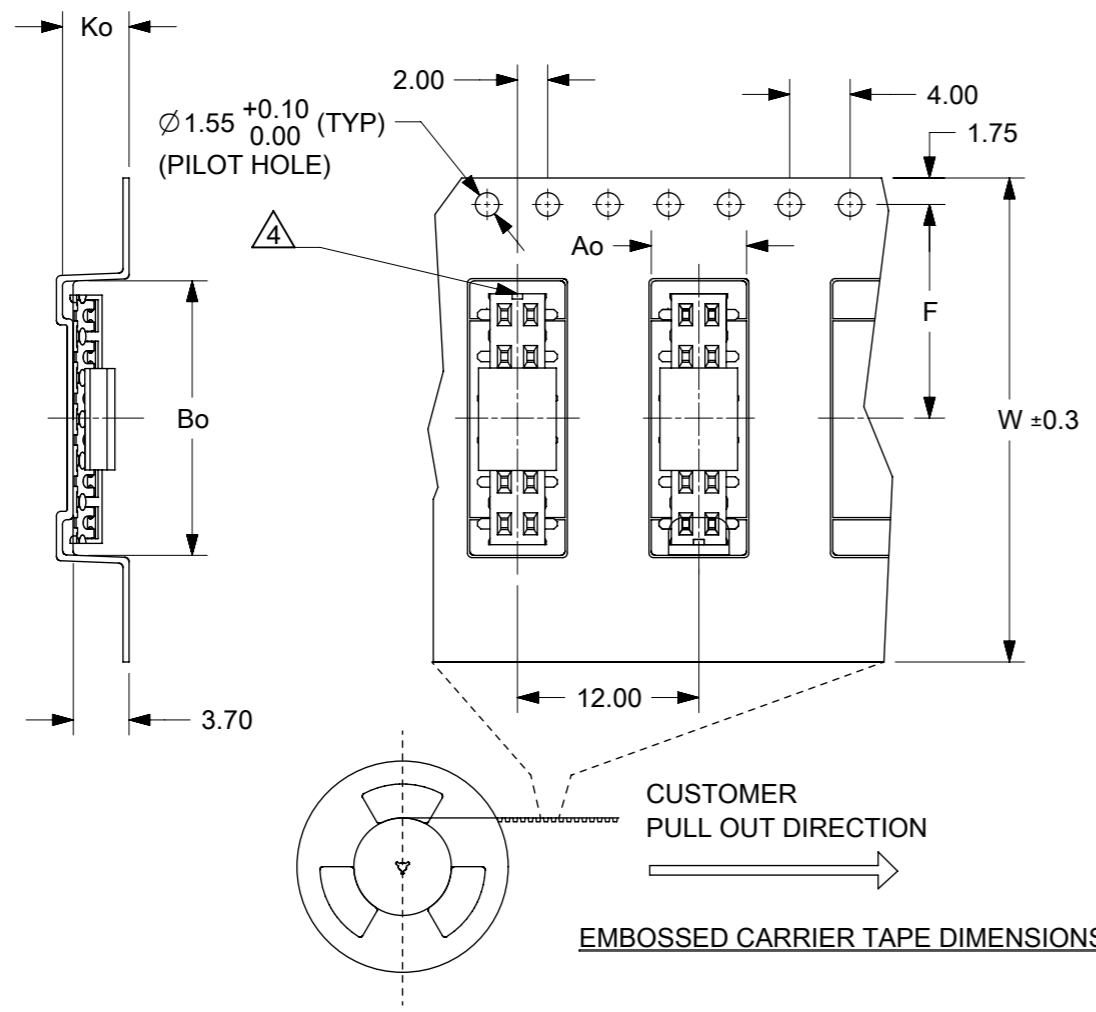

PART NO. W/CAP IN TAPE/REEL	CKT. SIZE	Ao	Bo	F	W	Ko
87340-04*6	4	6.70	5.30	11.50	24.00	5.30
87340-06*6	6	6.50	6.50	7.50	16.00	4.50
87340-08*6	8	6.70	8.40	11.50	24.00	5.30
87340-10*6	10	6.70	10.40	11.50	24.00	5.30
87340-12*6	12	6.60	12.40	11.50	24.00	4.40
87340-14*6	14	6.60	14.30	11.50	24.00	4.40
87340-16*6	16	6.60	16.30	11.50	24.00	4.40
87340-20*6	20	6.70	6.70	20.20	44.00	5.30

PART LEGEND NA FOR BELOW TABLE

PART NO. W/CAP IN TAPE/REEL	CKT. SIZE	Ao	Bo	F	W	Ko
87340-1196	10	6.70	10.40	11.50	24.00	5.30

NOTE: CKT 7 AND 8 UN-FILLED. REFER HOUSING DRAWING

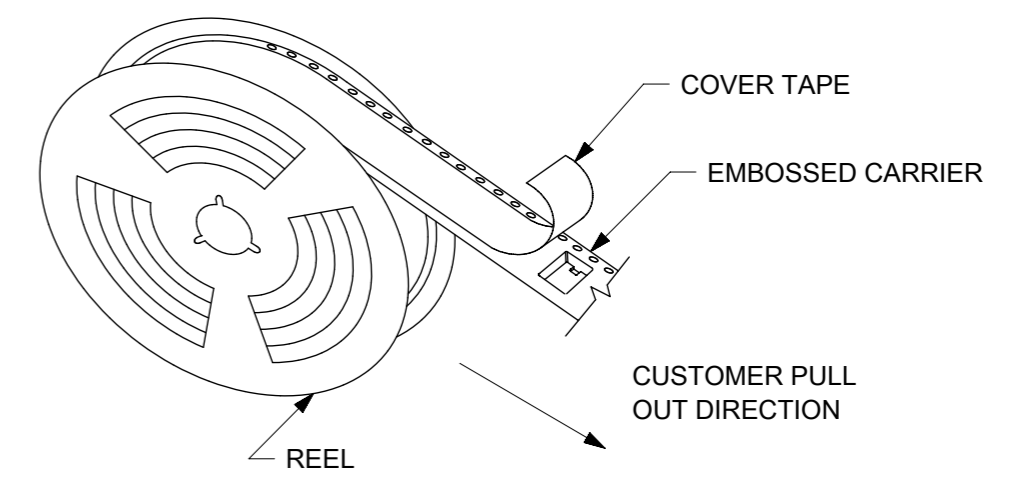

TAPE AND REEL ASSEMBLY SHOWN IS FOR ILLUSTRATION ONLY.

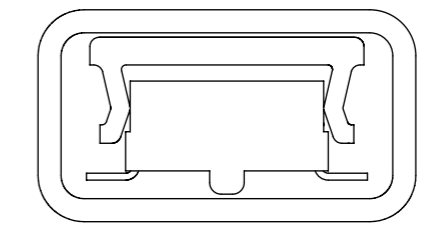

PART IN TUBE VIEW

NOTES:

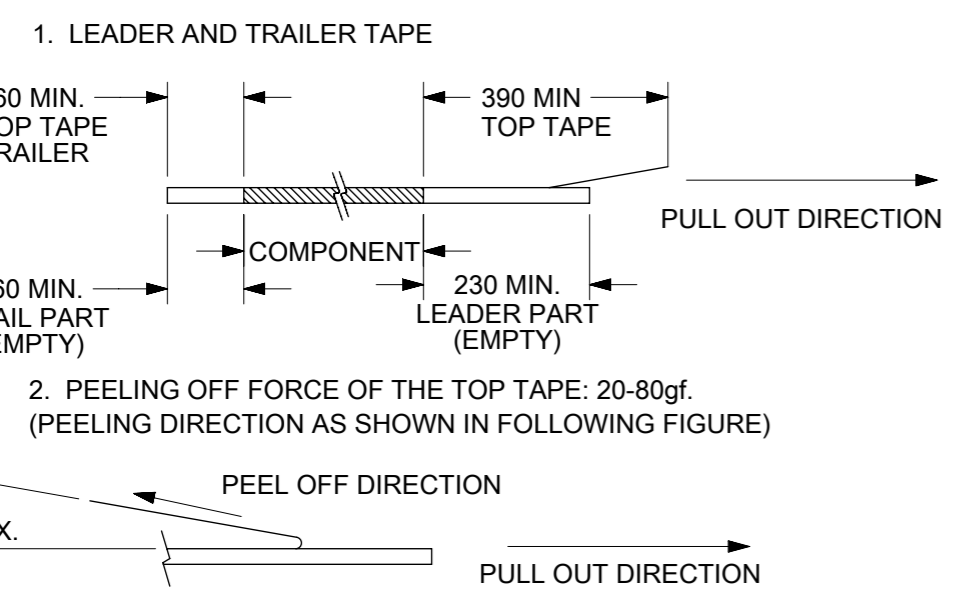

- 3. PACKAGING STANDARD IS AS PER EIA-481.
- 4. TAPE & REEL QUANTITY = 1000 PCS/REEL
- 5. NO FIX ORIENTATION OF ASSEMBLY PART IN T&R.

SYMBOLS	THIS DRAWING CONTAINS INFORMATION THAT IS PROPRIETARY TO MOLEX ELECTRONIC TECHNOLOGIES, LLC AND SHOULD NOT BE USED WITHOUT WRITTEN PERMISSION		CURRENT REV DESC:		
	DIMENSION UNITS: mm SCALE: NTS GENERAL TOLERANCES (UNLESS SPECIFIED): 4 PLACES ± 3 PLACES ± 2 PLACES ± 0.2 1 PLACE ± 0 PLACES ± ANGULAR TOL ± 3.0° DRAFT WHERE APPLICABLE MUST REMAIN WITHIN DIMENSIONS	EC NO: 740811 DRWN: DANUSA 2023/02/13 CHK'D: SUAIFR 2023/03/02 APPR: MRAMAKRISHNA 2023/03/03	INITIAL REVISION: DRWN: JWAN 1995/01/25 APPR: RWONG 1995/01/25	DOCUMENT NUMBER: SD-87340-XX92 DOC TYPE: PSD DOC PART: 001 REVISION: D5	
DOCUMENT STATUS: P1 RELEASE DATE: 2023/03/03 01:39:43	THIRD ANGLE PROJECTION:		DRAWING: A3-SIZE	SERIES: 87340	MATERIAL NUMBER: SEE TABLE CUSTOMER: GENERAL MARKET SHEET NUMBER: 2 OF 2