

# molex



**FA2 CRIMP APPLICATOR**  
**General Description, Setup and Operating Instructions**  
**Document No. 63808-0200**





**Start-Up Guide**  
**Page 10**









## Safety Warnings and Information

	<p><b>Read and understand</b> all instructions and safety information in this manual before operating or servicing this tool.</p> <p style="text-align: center;">Keep this manual available when using this tool. Replacement manuals are available for download at <a href="http://www.molex.com">www.molex.com</a>.</p>
---	---

<b>SAFETY ALERT SYMBOL</b>	
<p>This symbol is used to call your attention to hazards or unsafe practices that could result in an injury or property damage. The signal word, defined below, indicates severity of hazard. The message following the signal word provides information for prevention or avoidance of the hazard.</p>	
 <b>DANGER</b>	<p><b>DANGER:</b></p> <ul style="list-style-type: none"> <li>Indicates an imminently hazardous situation that, if not avoided, could result in death or serious injury</li> </ul>
 <b>WARNING</b>	<p><b>WARNING:</b></p> <ul style="list-style-type: none"> <li>Indicates a potentially hazardous situation that, if not avoided, could result in death or serious injury</li> </ul>
 <b>CAUTION</b>	<p><b>CAUTION:</b></p> <ul style="list-style-type: none"> <li>Indicates a potentially hazardous situation that, if not avoided, may result in minor or moderate injury</li> <li>May also be used to alert against unsafe practices associated with events that could lead to personal injury</li> </ul>

	<p><b>! DANGER</b></p> <p><b>Never</b> install or service this machine while connected to any electrical power source. Disconnect power by unplugging the press from its power source.</p> <p>Failure to observe this warning could result in severe injury or death.</p>
	<p><b>! WARNING</b></p> <p><b>Never</b> operate a press or wire processing machine without guards or safety devices that are intended to prevent hands from remaining in the die space.</p> <p>Failure to observe this warning could result in severe injury or death.</p>
	<p><b>! WARNING</b></p> <p><b>Never</b> wear clothing or jewelry that is loose or that could potentially hang into the equipment and get caught.</p> <p>Failure to observe this warning could result in severe injury or death.</p>
	<p><b>! WARNING</b></p> <p><b>Always</b> wear proper eye protection when operating or servicing this equipment.</p> <p>Failure to wear eye protection could result in serious eye injury from flying debris.</p>

	<p><b>CAUTION</b></p> <p><b>Do not use</b> compressed air to clean this equipment. The forces created by compressed air can force debris into the tool.</p> <p>Failure to observe these precautions may result in injury or property damage.</p>		<p><b>CAUTION</b></p> <p><b>Always</b> hand-cycle the applicator in the equipment to ensure tooling is properly aligned.</p> <p>Failure to observe these precautions may result in injury or property damage.</p>
	<p><b>CAUTION</b></p> <p><b>Heavy Object</b> To avoid muscle strain or back injury, use lifting aids and proper lifting techniques when removing or replacing.</p> <p>Failure to observe these precautions may result in injury or property damage.</p>		<p><b>CAUTION</b></p> <p><b>Never</b> operate, service, install or adjust this machine without proper instruction and without first reading and understanding the instructions in this manual and all applicable press or wire processing machine manuals.</p>
	<p><b>CAUTION</b></p> <p><b>Always</b> wear proper ear protection when operating or servicing this applicator.</p>		
	<p><b>CAUTION</b></p> <p>Molex applicators are designed to operate in presses with standard shut heights of 135.80mm (5.346”).</p> <p>Installation of crimp presses with other-than-standard shut heights can cause tool breakage. It is advisable to perform a check of the shut height before installation. Molex will not be liable for any damages as a result of applicator installation in a crimp press with an incorrectly set shut height.</p> <p>Failure to observe these precautions may result in injury or property damage.</p>		
	<p><b>CAUTION</b></p> <p><b>Never</b> perform any service or maintenance other than as described in this manual.</p> <p><b>Never</b> modify, alter or misuse the equipment.</p> <p>Molex crimp specifications are valid only when used with Molex terminals, applicators and tooling.</p> <p>Failure to observe this precaution may result in injury and property damage.</p>		

# Table of Contents

Safety Warnings and Information .....	3
Section 1 – General Description .....	6
1.1 Description.....	6
1.2 Features .....	6
1.3 General Applicator Parts Identification (Mechanical Feed) .....	7
1.4 General Applicator Parts Identification (Air Feed).....	8
1.5 Applicator Tooling Identification.....	9
Section 2 – Start-Up Guide.....	10
Section 3 – Troubleshooting.....	12
3.1 Applicator Troubleshooting .....	12
3.2 Crimp Troubleshooting .....	12
Section 4 – Setup and Operation.....	14
4.0 Press Shut Height.....	14
4.1 Applicator Installation and Removal .....	14
4.2 How to Make a Crimp .....	15
4.3 Crimp Height Adjustments .....	15
4.4 Track Guide Setup and Adjustment.....	16
4.5 Loading and Unloading Terminals in the Applicator Track.....	18
4.6 Terminal Feed Adjustments.....	19
4.7 Terminal Track Position Adjustment .....	22
4.8 Crimp Tooling Installation and Removal .....	23
4.9 Wire Stop Setup and Adjustment.....	25
4.10 Wire Processing Setup and Feed Cam Orientation .....	27
4.11 Bend Adjust Dial .....	28
Section 5 – Maintenance .....	29
5.1 Cleaning .....	29
5.2 Lubrication.....	29
5.3 Storage.....	30
Section 6 – Service Parts .....	31
6.1 Feed Pawl Spring Replacement .....	32
6.2 Accessories .....	33
6.3 Contact Us.....	33
Section 7 – Crimp Quality.....	34

## Section 1 – General Description

### 1.1 Description

The FA2 applicator fits in the Molex TM-2000, TM-3000 and TM-4000 Universal Presses and in most industry-standard crimp presses with 135.8mm (5.346") shut height and 3-point base plate mounting to the press bolster.

Molex currently offers the following crimp presses for operating the FA2 applicator:

Description	Order Number
TM-3000 Press 120 V 50/60 Hz	63801-7200
TM-3000 Press 240 V 50/60 Hz	63801-7300
TM-4000 Press 240 V 50/60 Hz	63801-7600

### 1.2 Features

- Fine adjustment allows users to achieve target with little effort by adjusting in increments of 0.015mm (.0006") for conductor crimp height and in increments of .025mm (.001") for insulation crimp height.
- Independent adjustment cams allow users to quickly adjust conductor or insulation crimp height without affecting each other.
- The track position for bellmouth and cut-off tab can be adjusted while the applicator is in the press.
- This applicator does **NOT** fit in the Molex TM-40 or TM-42 presses.
- Directly adapts to most automatic wire processing machines.
- Compatible with 30mm and 40mm stroke presses; no changes necessary in applicator.
- Quick setup time; crimp heights, track position, and feed adjustments can be adjusted while the applicator is in the press.
- **This applicator is designed to industry-standard 3-point mounting and 135.80mm (5.346") shut height.**

#### Press Stroke Compatibility

- 28.6mm (1 1/8") minimum
- 41.3mm (1 5/8") maximum

#### Applicator Mounting in Press

- This applicator uses the industry-standard 3-point base plate mounting to the press bolster and T-shape industry-standard ram mounting.

#### Guarding

This applicator is supplied without guards and is intended to be used with guards supplied by the press manufacturer.



**Caution: DO NOT** operate the applicator without guards.

1.3 General Applicator Parts Identification (Mechanical Feed)

 Indicates manual page number for more information

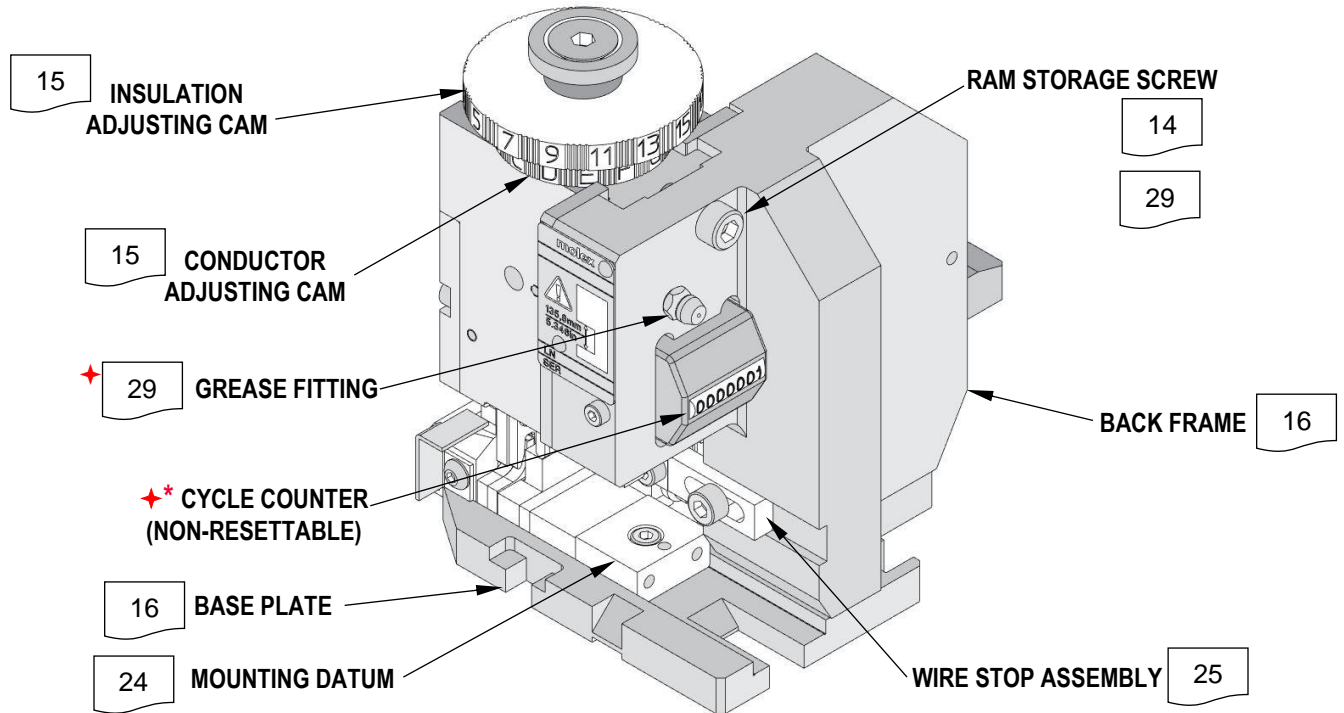
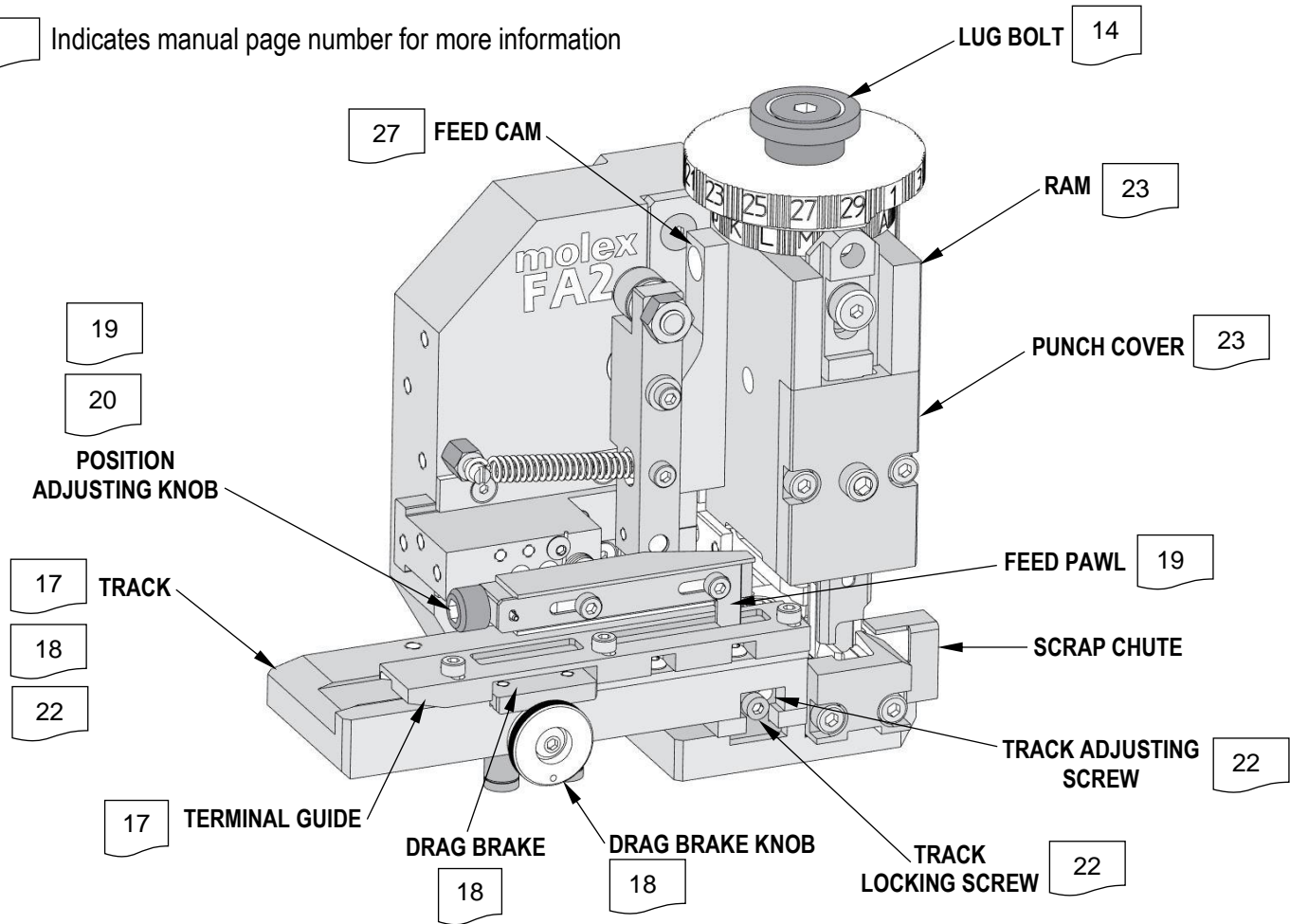

\* Depending on conditions during applicator assembly and setup, the counter reading may vary on new applicators.

† Newer FA2 applicators don't have grease fitting and cycle counter.

1.4 General Applicator Parts Identification (Air Feed)

 Indicates manual page number for more information

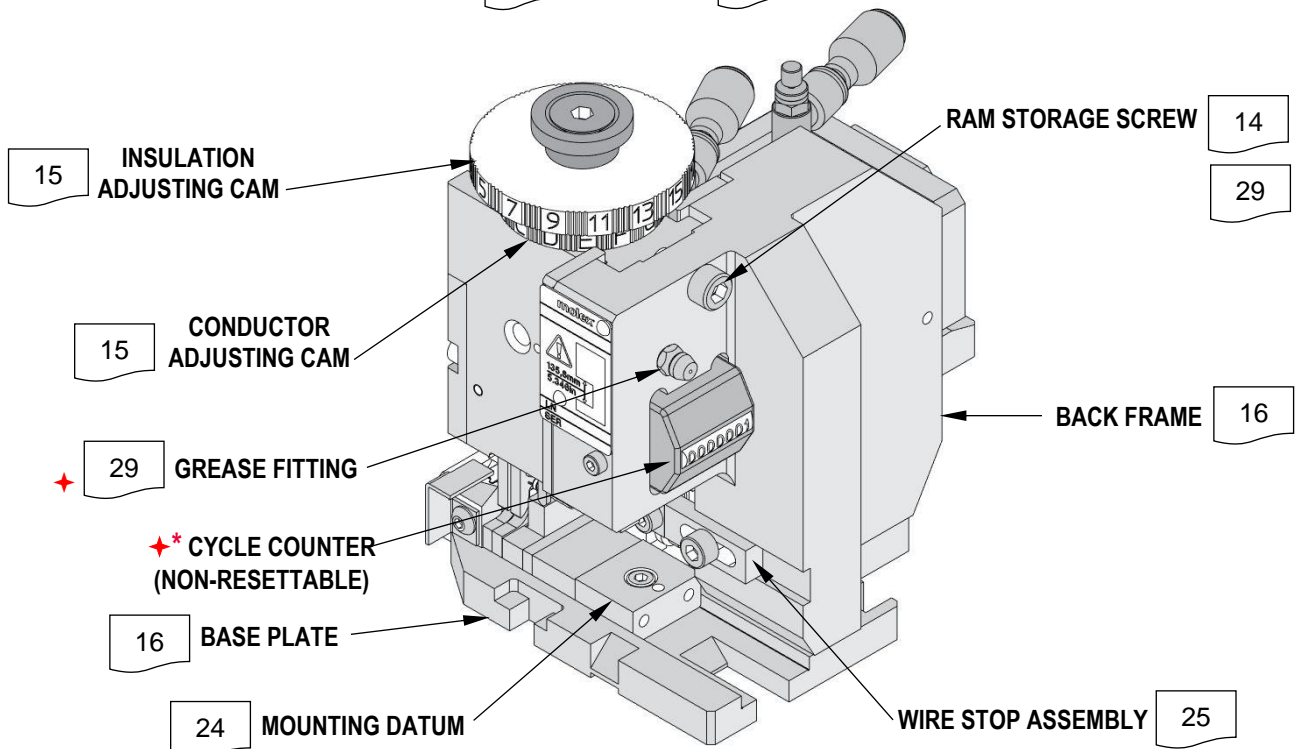
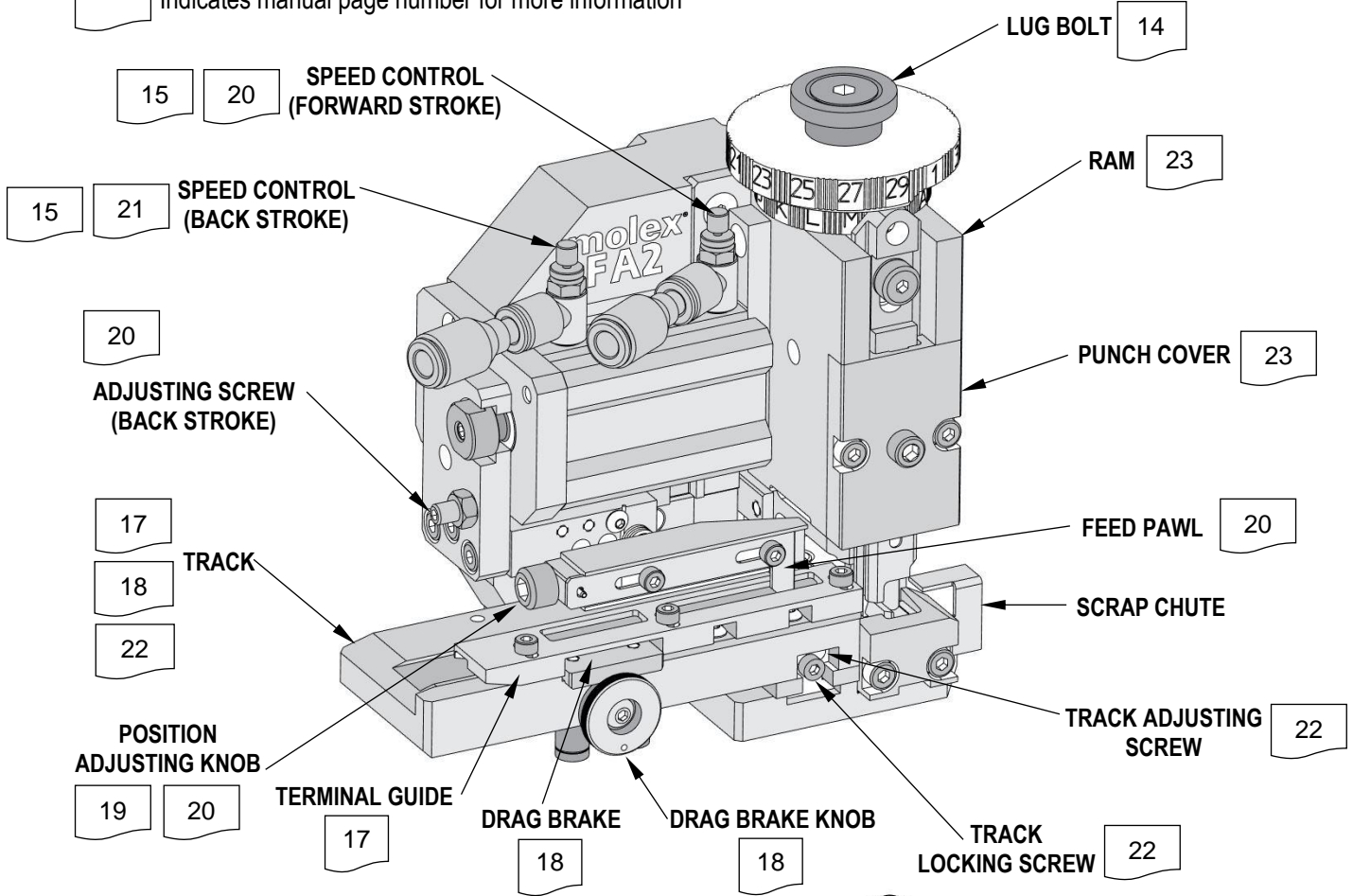

\* Depending on conditions during applicator assembly and setup, the counter reading may vary on new applicators.  
 \* Newer FA2 applicators don't have grease fitting and cycle counter.



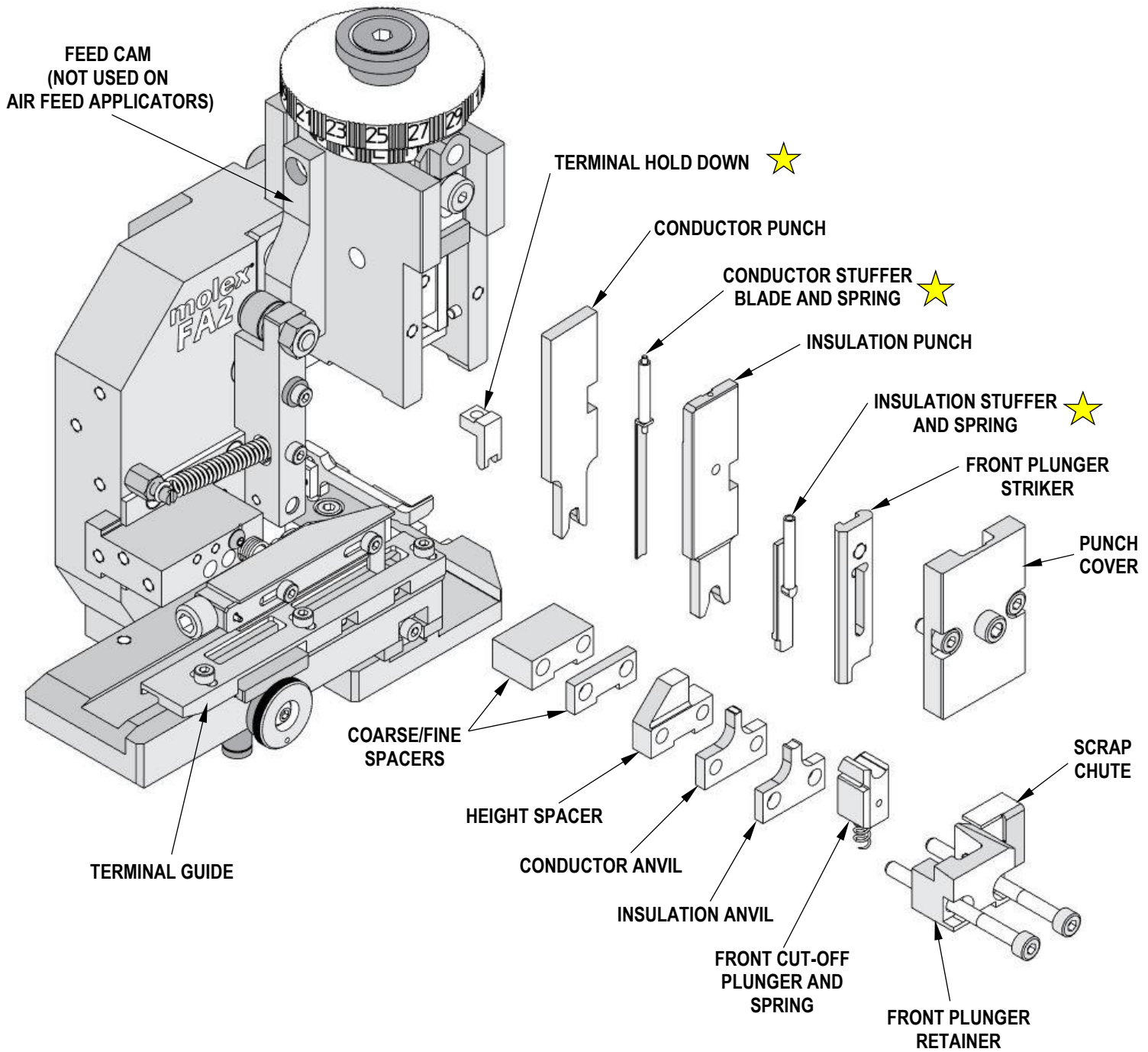

### 1.5 Applicator Tooling Identification

★ Tooling component used on some applicators

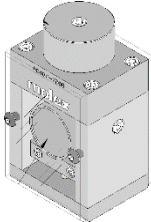
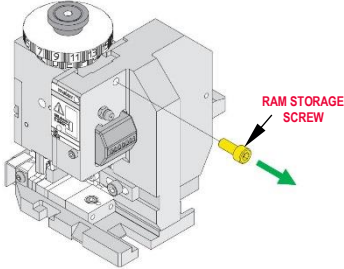

**Note:** The above is a generic illustration. Please refer to the Application Tooling Specification (ATS) document for your specific applicator to identify replacement parts and part numbers.

# Section 2 - Start-Up Guide

Step	Instruction	Page
<b>1</b>	<p><b>Verify Press Compatibility</b></p> <ul style="list-style-type: none"> <li>○ Press stroke is between 26.8-41.2mm (1 1/8-1 5/8")</li> <li>○ Press shut height is 135.8mm (5.346")</li> <li>○ 3-point universal base plate mounting</li> <li>○ T-shape universal ram mounting</li> </ul>	5, 12
		
<b>2</b>	<p><b>Confirm Terminal, Wire and Tool</b></p> <p>Use the applicator's ATS document to confirm the applicator is compatible with Molex terminal part number and selected wire (conductor size and insulation diameter).</p>	ATS
<b>3</b>	<p><b>Set Up Applicator for Wire Processing (If Applicable)</b></p> <ul style="list-style-type: none"> <li>○ As shipped, Molex applicators are set up for bench crimping.</li> <li>○ For wire processing applications, please review section 4.10.</li> </ul>	25
	<p><b>Test Fit Terminal Strip in the Track</b></p> <ul style="list-style-type: none"> <li>○ Make adjustments to the guide cover if terminals are too tight or loose.</li> </ul>	
<b>4</b>	<p><b>Install Applicator in Press</b></p> <ul style="list-style-type: none"> <li>○ <b>Remove ram storage screw.</b></li> <li>○ Install the applicator into the press and engage the lock.</li> <li>○ Connect the air lines (air feed applicators only) to the air valve.</li> </ul>	12-13
		
<b>5</b>	<p><b>Install Terminal Reel and Load Terminals in Track</b></p> <ul style="list-style-type: none"> <li>○ Terminal strip must slide freely in track without excessive play.</li> <li>○ Center the first terminal above the anvils.</li> <li>○ Make sure the drag brake is ON before operating the press.</li> </ul>	16-20
<b>6</b>	<p><b>Hand-Cycle/Slow-Cycle the Press</b></p> <ul style="list-style-type: none"> <li>○ Record the insulation adjusting cam and conductor adjusting cam factory settings.</li> <li>○ To prevent tool damage, move the insulation adjusting cam to setting 1 and the conductor adjusting cam to setting A.</li> <li>○ Verify back feed pawl position engages the terminal strip carrier hole.</li> <li>○ Stop the press if there is any tightness or binding.</li> <li>○ Stop the hand-cycle/slow-cycle when the press ram is at the top of its stroke.</li> <li>○ Verify the forward feed position (terminal centered over anvils).</li> <li>○ Hand-cycle/slow-cycle several times to crimp terminals and evaluate the feed and cut-off tab.</li> </ul>	13-14, 18-19
		
<b>7</b>	<p><b>Crimp with Wire (Production Speed)</b></p> <ul style="list-style-type: none"> <li>○ Verify that terminals feed properly before crimping under power.</li> <li>○ Close the guards and turn on press power.</li> <li>○ Crimp a pre-stripped wire and evaluate. Crimps will be loose because the insulation adjusting cam and conductor adjusting cam are at their loosest settings.</li> <li>○ Move the insulation adjusting cam and conductor adjusting cam halfway to the factory settings and crimp again.</li> <li>○ Begin measuring the crimp heights and compare to ATS specifications.</li> <li>○ Incrementally increase the insulation adjusting cam and conductor adjusting cam settings over several crimps until ATS crimp specifications are met.</li> </ul>	13-14, 17-19
		

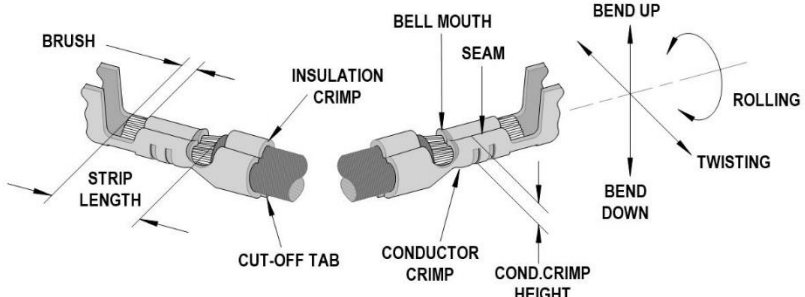
<p><b>8</b></p>	<p><b>Inspection</b></p> <ul style="list-style-type: none"> <li>Measure crimp characteristics as specified in the ATS and adjust accordingly.</li> </ul> 	<p>ATS</p>
<p><b>9</b></p>	<p><b>Ready for Production</b></p>	<p></p>

### Visual Inspection of Crimped Terminals

#### Examples

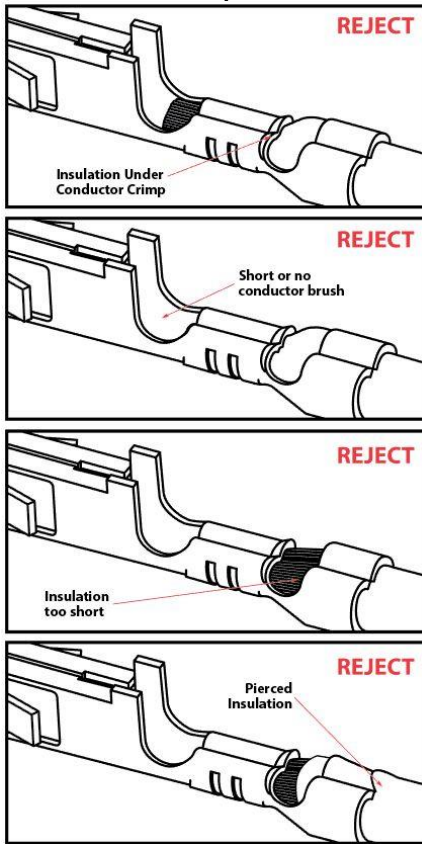

#### Optimal Crimp

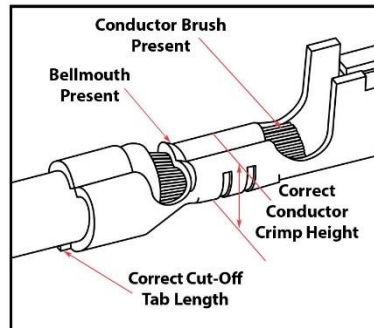

#### Improper Wire Preparation

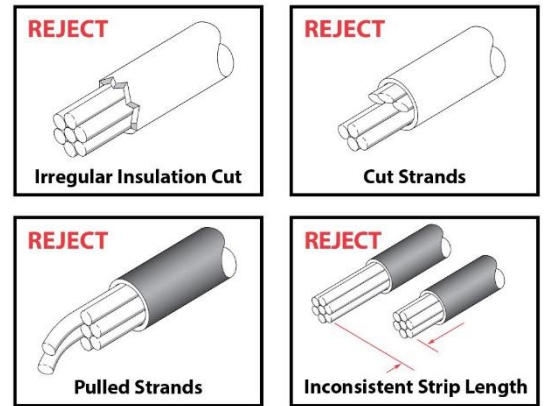

#### Measurement of Crimp Height

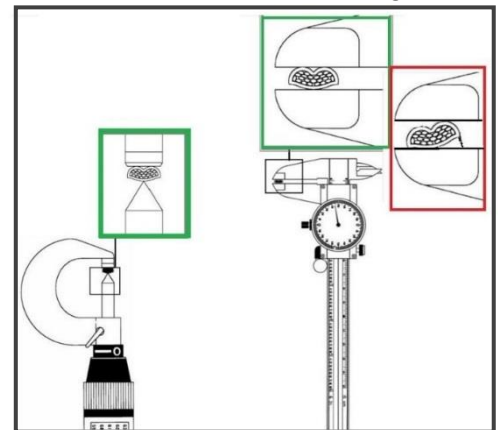

#### Application Tooling Support

Phone: (402) 458-TOOL (8665)  
 E-Mail: toolingsupport@molex.com  
 Website: www.molex.com/applicationtooling

## Section 3 – Troubleshooting

### 3.1 Applicator Troubleshooting

**Note:** ATS refers to the Application Tooling Specification document for the applicator.

Symptom	Cause	Solution	See Page	
Terminals not feeding or inconsistent feed	Terminal strip bent or damaged	Replace terminals	—	
	Terminal strip pulled tight from reel	Terminals should be loose loop from the reel	21	
	Feed pawl not properly adjusted	Check proper pawl setting	17	
	Tip of feed pawl worn	Replace feed pawl	—	
	Drag brake not on	Rotate drag brake knob (dot down)	18-19	
	Feed pawl not moving back enough to pick up the terminal (pitch)	Mechanical feed applicator: Verify correct feed cam installed		ATS
		Air feed applicator: Adjust back stroke		21
	Terminal jammed under terminal guide	Clear and reinsert terminals	18	
	Feed pawl guide not aligned to terminal strip's carrier holes	Readjust feed pawl guide	17	
	Terminal guide adjusted too tight	Readjust terminal guide	17-18	
Track adjusted too far out (terminal insulation grips rubbing on cut-off plunger)	Adjust track in (away from operator) for proper cut-off tab and bellmouth size		22	
Cut-off plunger stuck down	Plunger retainer screws overtightened	Loosen screws and re-tighten	—	
	Cut-off plunger spring fatigued or broken	Replace spring per specification sheet	ATS	
	Debris buildup in plunger area	Disassemble and clean	—	
	Carrier strip jammed in cut-off plunger	Cut out damaged terminal strip and feed in clean strip	—	
	Cutting edges worn or damaged (cut-off plunger, retainer or insulation anvil)	Remove scoring marks and if problem not solved, replace the worn cut-off plunger, cut-off retainer or insulation anvil		ATS

### 3.2 Crimp Troubleshooting

Symptom	Cause	Solution	See Page	
Crimp bellmouth too large or cut-off tab too small	Wrong crimp tooling	Replace per specification sheet	ATS	
	Wrong terminal	Replace per specification sheet	ATS	
	Worn or damaged tooling	Replace per specification sheet	ATS	
	Track adjusted too far out (toward operator)	Adjust track in (away from operator) to reduce bellmouth or increase the cut-off tab		22
Crimp bellmouth too small or cut-off tab too large	Track adjusted too far in (away from operator)	Adjust track out (toward the operator) to increase bellmouth or cut-off tab		22
	Wrong crimp tooling	Replace per specification sheet	ATS	
Conductor crimp too loose (per specification)	Wrong crimp tooling	Replace per specification sheet	ATS	
	Worn or damaged tooling	Replace per specification sheet	ATS	
	Wrong conductor cam setting	Measure crimp height and adjust accordingly	15-16	
	Press shut height too high (loose)	Calibrate press shut height to 135.8mm	14	
Conductor crimp too tight (per specification)	Wrong crimp tooling	Replace per specification sheet	ATS	
	Wrong conductor cam setting	Measure crimp height and adjust accordingly	15-16	
	Press shut height is too low (tight)	Calibrate press shut height to 135.8mm	14	

Symptom	Cause	Solution	See Page
Insulation crimp too loose (poor strain relief)	Wire insulation diameter too small	Verify insulation diameter is within specification	ATS
	Wrong insulation cam setting	Adjust insulation cam for tighter crimp	15-16
	Worn or damaged tooling	Replace tooling if necessary	ATS
Insulation crimp too tight (damaging insulation)	Wire insulation diameter too large	Verify insulation diameter is within specification	ATS
	Wrong insulation cam setting	Adjust insulation cam for looser crimp	15-16
	Wrong insulation crimp tooling	Replace with correct tooling	ATS
	Press shut height is too low	Calibrate press shut height to 135.8mm	14
Terminal sticks in crimp punches after crimping	Conductor and/or insulation cam setting causing over-crimping	Measure crimp height and adjust cams accordingly	15-16
	Incorrect crimp tooling or wire conductor size	Replace with correct tooling or conductor size per specification sheet	ATS
	Wire stop missing or not adjusted	Review specification sheet for missing components	ATS
	Crimp tooling worn or damaged	Replace per specification sheet	ATS
	Wire insulation too large for tooling	Loosen insulation crimp cam to 1 to test; review the insulation diameter specification	ATS
	Gold plating (including selective plating) or some high-tensile materials	Install a terminal oiler and potentially replace tooling	23-24
Terminal nose bend up or bend down after crimping	Terminal sticking in crimp punches	(See above troubleshooting)	—
	Terminal track adjusted too far in or out	Adjust track for correct bellmouth and cut-off tab	22
	Terminal nose hold down misadjusted or missing	Refer to specification sheet if applicable	ATS
Wire brush length is inconsistent	Wire stop out of adjustment	Adjust accordingly	23-24
	Wire stop missing	Replace per specification sheet	ATS
	Wire stripping inconsistent	See strip length range on specification sheet	ATS
	Wire is being inserted into the terminal instead of being put against the wire stop	Touch end of stripped wire to the face of the wire stop assembly target	—
	Operator applying inconsistent force against wire stop assembly target with the end of the stripped wire to the face of the wire stop assembly target	Adjust method of presenting the end of the stripped wire to the wire stop assembly target	—
Excessive crimp extrusion ( <i>flash</i> )	Terminal is over-crimped	See above (Conductor crimp too tight)	15-16
	Conductor too big for terminal	Verify conductor size per specification sheet	ATS
	Crimp tooling worn or damaged	Replace tooling per specification sheet	ATS
	Gold plating or some high-tensile materials	Install a terminal oiler and potentially replace the tooling	—
	Wrong crimp tooling (punch and anvil)	Verify tooling per specification sheet	ATS

## Section 4 – Setup and Operation

### 4.0 Press Shut Height

**This applicator must be installed in a crimp press with a standard 135.80mm (5.346") press shut height.**

- Shut height should be verified with a calibrated shut height gauge.
- Molex offers a shut height gauge (Order No. 63800-7900).

### 4.1 Applicator Installation and Removal

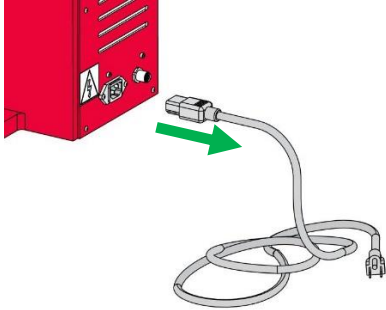
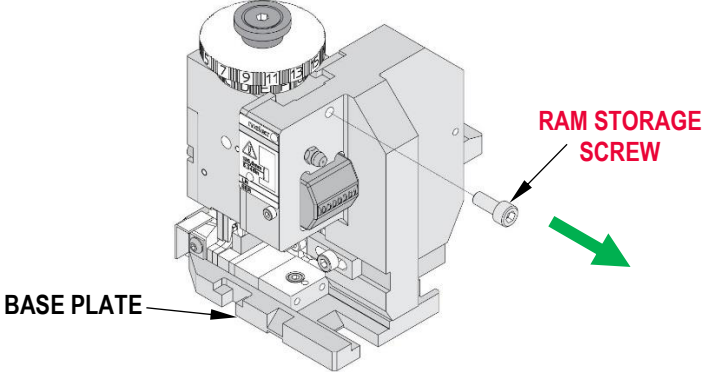
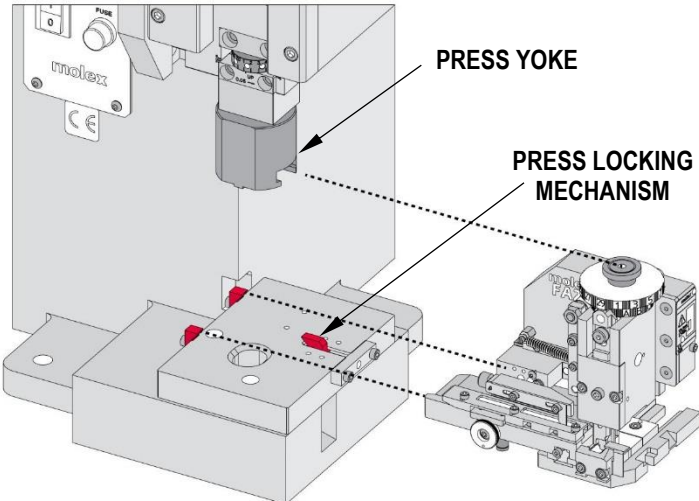
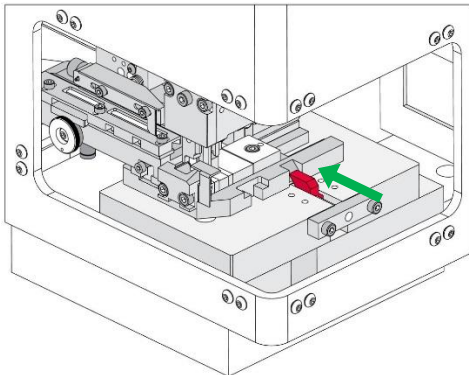
	
<p>1. Disconnect power to the press.</p>	<p>2. Clean the bottom of the applicator base plate and the top of the press bolster of scrap or chips that may interfere with flat applicator installation.  <b>3. Remove the ram storage screw from the back of the applicator frame.</b></p>
	
<p>4. Fit the applicator lug bolt into the press yoke, and align the base plate notches to the press locking mechanism.</p>	<p>5. Clamp the applicator in the press.</p>

Remove the applicator by reversing the previous steps. For applicator storage instructions, see Section 5.3.

## Pneumatic Connection (Air Feed)

1. The air feed applicator uses a double-acting air cylinder that must be actuated by a 4-way air valve.
2. The air cylinder is equipped with push-in fittings for 6mm diameter vinyl or Nylon tube. Adapters are included for 1/4" diameter and 4mm diameter vinyl or Nylon tube.

**Note:** The TM-3000 and TM-4000 presses have air valves with 1/4" diameter tube fittings. Be sure to install the 1/4" diameter adapters in the air cylinder fittings, and use 1/4" diameter vinyl or Nylon tube.

3. Pneumatic tubes must be connected as shown in Figure 4.1.1. Tubes are typically connected so the terminal feed is forward when the applicator ram is up.
4. When using the TM-3000 or TM-4000 presses, connect the tubes to the press air valve as shown in Figure 4.1.2

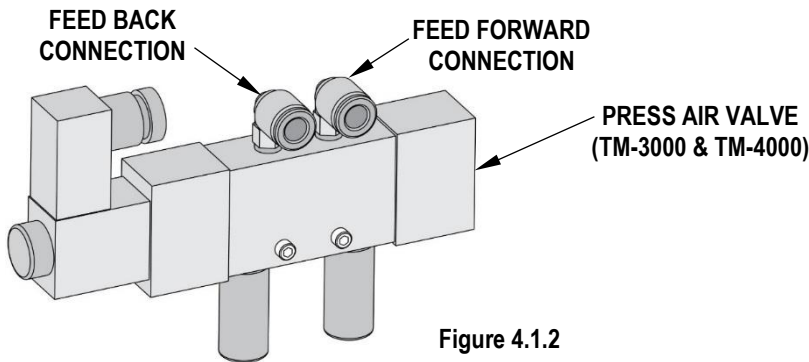

Figure 4.1.2

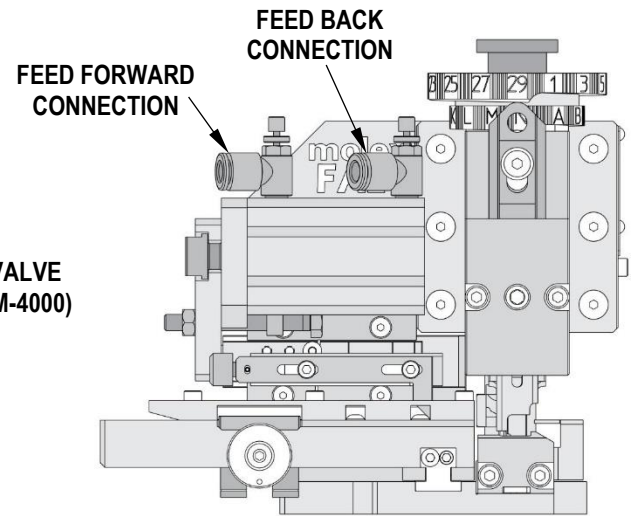

Figure 4.1.1

## 4.2 How to Make a Crimp

Review the ATS document, and strip the wires to the recommended length.

1. Close the guards and power up the machine. Aim the work light as necessary on the crimp tooling.
2. Insert the wire through the guard door and against the wire stop assembly target.
3. Apply light pressure to the wire at this time. Do not push the wire to where it is under tension and bends.
4. Depress the foot switch to activate the press and make the crimp. Then, remove the crimped wire from the machine.
5. Evaluate the crimp for any necessary adjustments.

**Note:** Molex recommends performing a setup with the crimp height cams at their loosest setting (A, 1) to verify that the feed and cutoff are functioning properly. This will help prevent tooling damage.

## 4.3 Crimp Height Adjustments

1. **Insulation crimp height** is adjusted by rotating the insulation adjusting cam on the ram. See Figure 4.3.1. The loosest (highest) crimp height is position 1, and the tightest (lowest) crimp height is position 29. Each click of this cam is approximately 0.025mm (.001") adjustment.
2. **Conductor crimp height** is adjusted by rotating the conductor adjusting cam on the ram. See Figure 4.3.1. The loosest (highest) crimp height is position A, and the tightest (lowest) crimp height is position N. Each click of this cam is approximately a 0.015mm (.0006") adjustment.
3. Insulation and conductor crimp height adjustments are independent. Adjusting one does not influence the other.

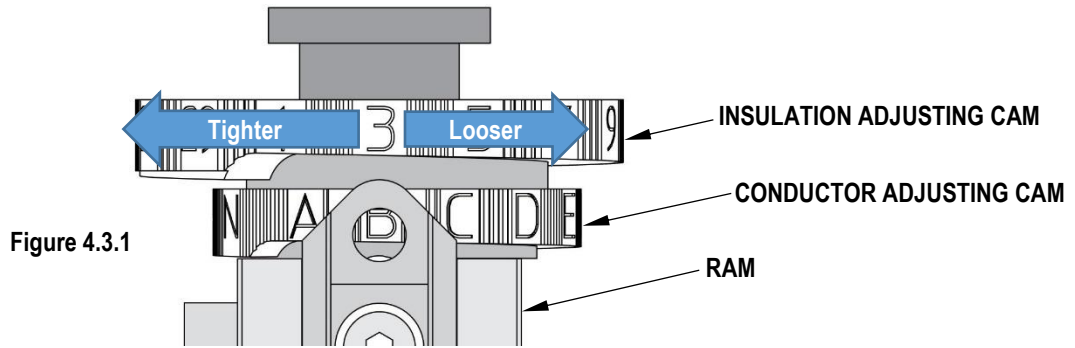

**Note:** Due to the large variety of insulation wall thicknesses, materials and diameters, Molex does not always specify insulation crimp height. For each different wire type, insulation crimp height can be measured, recorded and inspected as a quality indicator.

#### 4.4 Track Guide Setup and Adjustment



**IMPORTANT**

Electrical and pneumatic power must be disconnected from the press during setup. Manual press cycling (or slow cycling) is an absolutely required procedure for safety and for preventing equipment damage. Always hand-cycle the press when troubleshooting or making adjustments to tooling, applicators or accessories.

All applicators are set up and tested by trained Molex technicians prior to shipping from Molex. Each applicator is supplied with the crimp samples produced during the initial setup. The applicator is not set up with the customer's specific terminal and wire gauge. Customers must **RE-SET UP** the applicator

**DO NOT** loosen screws holding the back frame to the base plate. The back frame of this applicator is **NOT** doweled to the base plate. If the screws holding the back frame to the base plate are loosened, then the applicator will need to be returned to Molex for realignment.

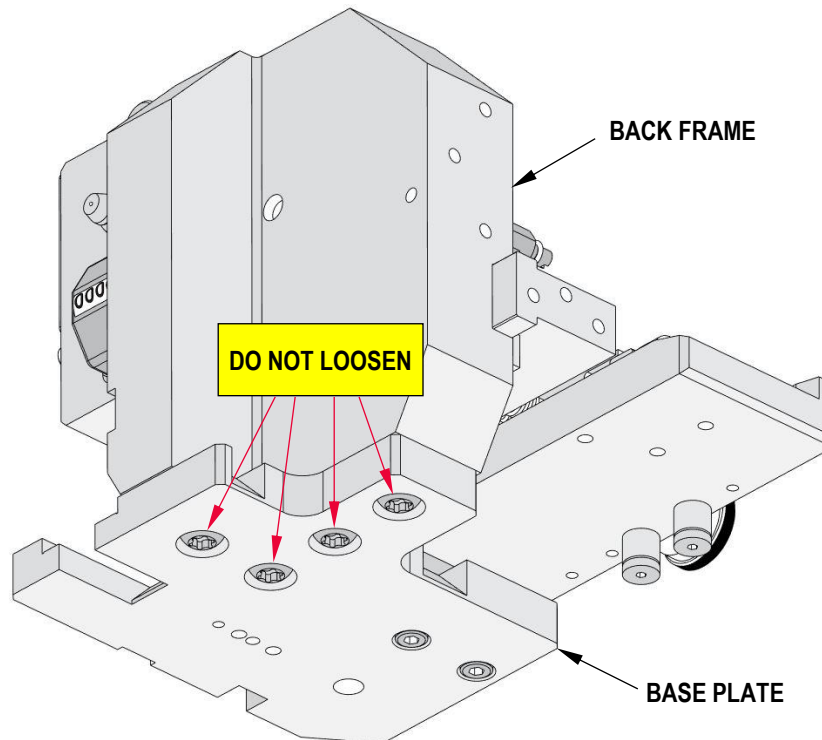

Figure 4.4.0



## Track Guides

The applicator's terminal track uses two adjustable guides. See Figure 4.4.1:

- **Feed Pawl Guide:** The slot in the feed pawl guide is aligned to pilot holes in the terminal carrier strip and provides feed pawl guidance. See Figure 4.4.2.
- **Terminal Guide:** The terminal guide steers the terminal strip through the track to maintain consistent crimp bellmouth and cut-off tab. See Figure 4.4.1.

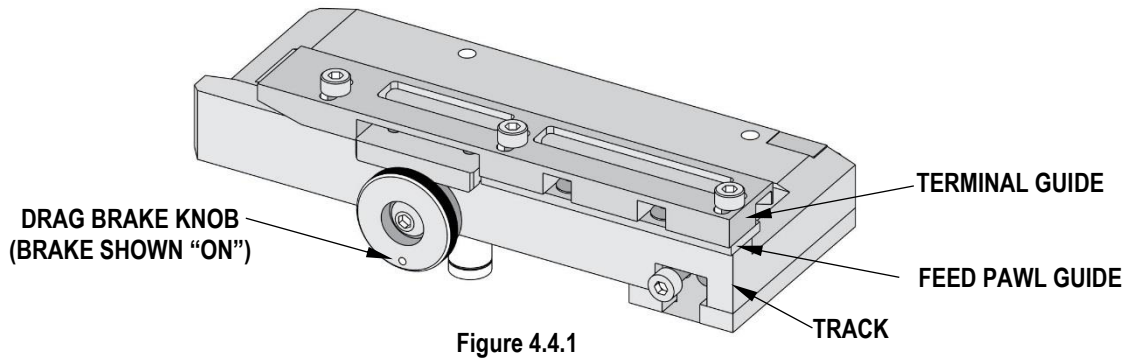

Figure 4.4.1

### Feed Pawl Guide Adjustment

1. Remove the applicator from the press.
2. Remove the terminal guide.
3. Turn the drag brake off (turn the drag brake knob until the dot is up), and load a short section of terminals in the track.
4. Make sure the terminal carrier is against the track lip, and turn the drag brake on (turn the drag brake knob until the dot is down). This holds the terminal strip in place.
5. Look straight down into the feed pawl guide slot. The slot must be centered to the centerlines of the pilot holes in the terminal carrier strip. See Figure 4.4.2.

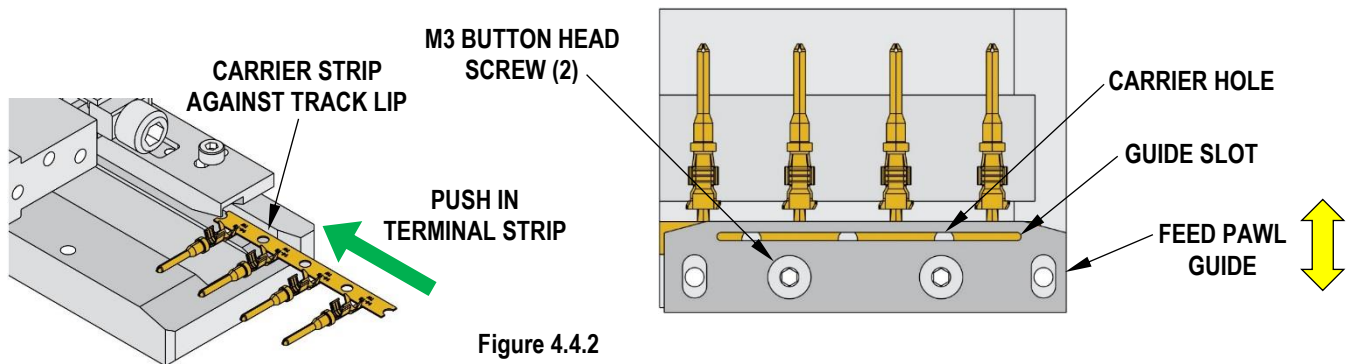

Figure 4.4.2

6. If the guide needs adjustment, loosen the two M3 button head screws, and move the guide forward or backward until the slot is centered.
7. Tighten the two M3 button head screws.
  - **Caution:** Do not overtighten. Button head screws strip if overtightened. Just make the screws snug.

### Terminal Guide Adjustment

1. Remove the applicator from the press.
2. Turn the drag brake off (turn the drag brake knob until the dot is up), and load a short section (150mm or 6") of terminals in the track.
3. Use a 2.5mm hex wrench to loosen the three M3 screws holding the guide. See Figures 4.4.3 and 4.4.4.

4. Move the guide toward or away from the operator to adjust the fit of the terminals in the track.
  - If the terminal guide is adjusted too far away from the operator, terminals will be too loose in the track and may create varying bellmouth or cut-off tab.
  - If the terminal guide is adjusted too far toward the operator, terminals will be a tight fit in the track and may create feed problems or terminal damage.
5. When the terminal guide adjustment is complete, tighten the three M3 screws. Recheck terminal fit in the track and adjust if necessary.

**NOTE:**

**DO NOT remove the applicator back frame from the base plate. The back frame of this applicator is NOT doweled to the base plate. If the back frame screws are loosened, then the applicator will need to be returned to Molex for realignment.**

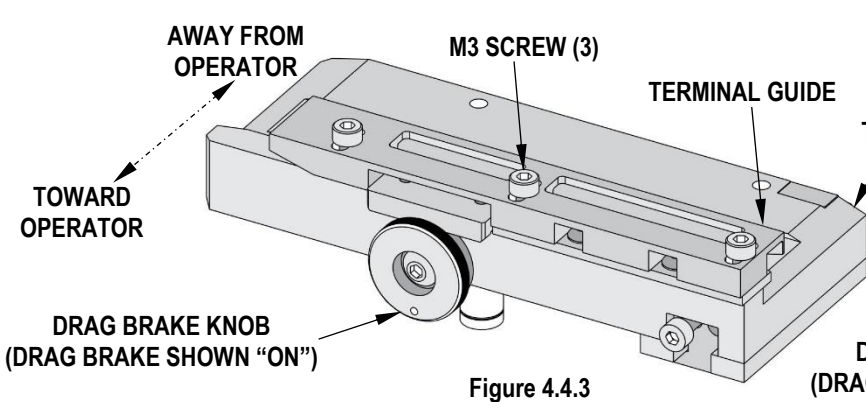

Figure 4.4.3

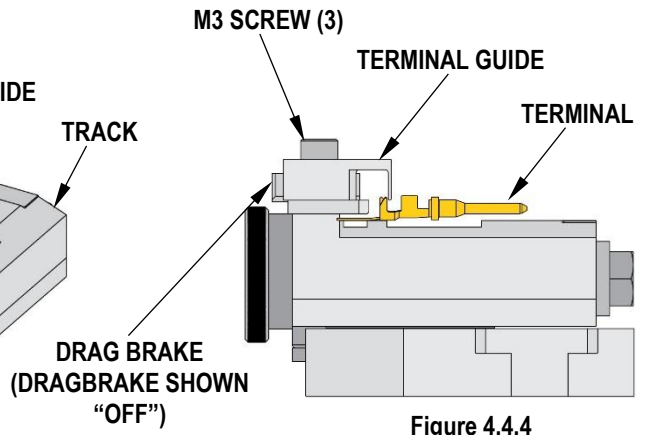

Figure 4.4.4

**4.5 Loading and Unloading Terminals in the Applicator Track**



**Caution: Always disconnect press power before installing or removing tooling.**

**Caution: DO NOT operate the applicator without guards in place.**

1. Before loading terminals in the track, make sure the ram is in the up position.
2. Disconnect power to the press. Remove machine guards if necessary.
3. Rotate the drag brake knob until the dot is up. The dot on the drag brake knob indicates the drag brake status. See Figure 4.5.1.
  - When the dot is down, the drag brake is on (applying drag to the terminal carrier).
  - When the dot is up, the drag brake is off (not applying drag to the terminal carrier).
4. Align the terminal carrier against the lip in the track and push the terminal strip in until the first terminal is approximately centered above the crimp anvils. See Figures 4.5.2 and 4.5.3.
5. Rotate the drag brake knob until the dot is down (drag brake on).
6. For mechanical feed applicators with [pre-feed timing](#), hand-cycle the press so the feed pawl retracts and feeds the next terminal to a centered position over the anvils. See Figure 4.5.3.
7. For mechanical applicators with [post-feed timing](#), the upper tooling must be removed (prior to hand-cycling the press) to inspect terminal position over the anvils. See Section 4.8 for removal of upper tooling.

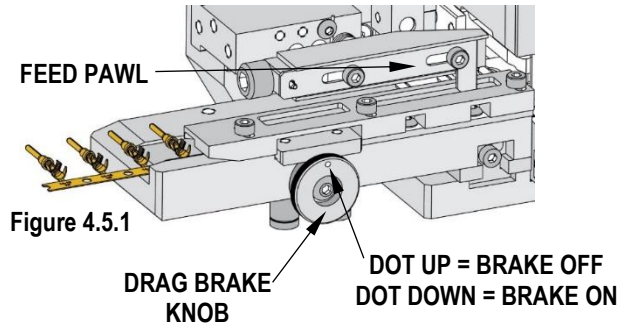

Figure 4.5.1

8. For air feed applicators, turn the press air valve on and off so the feed pawl retracts and feeds the terminal to a centered position over the anvils.

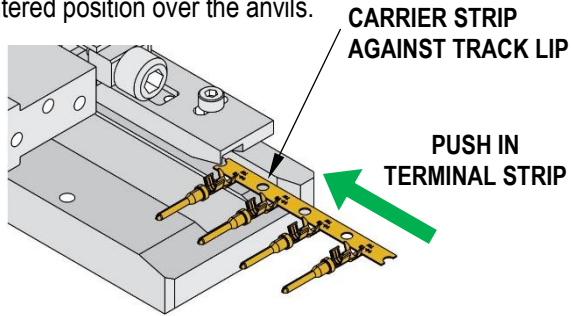

Figure 4.5.2

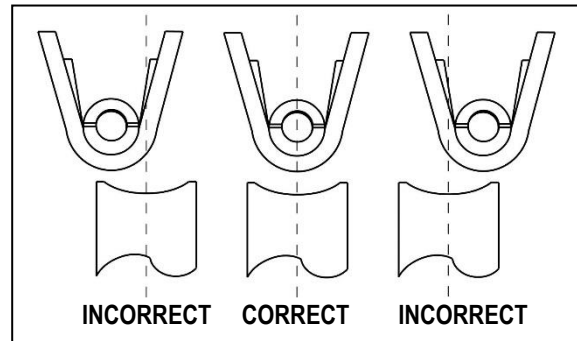

Figure 4.5.3

9. After feeding the terminal, the terminal must be centered over the anvils. See Figure 4.5.3. If the terminal is not centered over the anvils, use the terminal feed adjustment procedure (Section 4.6) to correct the position.

**Note:** It is recommended to repeat steps 6-9 several times to ensure the terminal is exactly centered over the anvils.

### Unloading the Terminal Strip from the Applicator Track

1. Make sure power to the press is disconnected. Remove machine guards if necessary.
2. Rotate the drag brake knob until the dot is up (drag brake off).
3. Raise the feed pawl, and pull the terminal strip backward until it is disengaged from the applicator track. The terminal carrier strip can also be cut at the track entrance and pulled forward through the applicator with needle nose pliers.

## 4.6 Terminal Feed Adjustments

### Feed Adjustment: Mechanical (Cam) Feed Applicators

Terminal feed stroke is controlled by a feed cam that is designed for the specific terminal being crimped. The back-stroke of the feed is determined by the feed cam and is not adjustable. The forward position of the feed pawl is adjustable to center the terminal exactly over the crimp anvils using the position adjusting knob. See Figure 4.6.1.



**Caution:** Always disconnect press power before installing or removing tooling.



**Caution:** DO NOT operate the applicator without guards in place.

1. Disconnect power to the press. Load terminals in the track, and make sure the drag brake is on (dot facing down).
2. Depending on the feed cam mounting (pre-feed or post-feed), hand-cycle the press ram until the feed pawl is in the forward position.
  - **Note:** For applicators with post-feed timing, the upper tooling must be removed to inspect terminal position over the anvils. See Section 4.8 for removal of upper tooling.
3. While holding the feed pawl lever down (this keeps the lever from jumping up), loosen the two M3 screws on the feed pawl about one turn each.
4. Turn the position adjusting knob clockwise (left to right) to increase the forward feed position or counterclockwise (right to left) to decrease the forward feed position. When decreasing the forward feed position, the terminal strip needs to be pulled back against the feed pawl to observe the change.
5. Tighten the M3 screws to lock the feed pawl in position.
6. Hand-cycle the press, and check forward feed position.

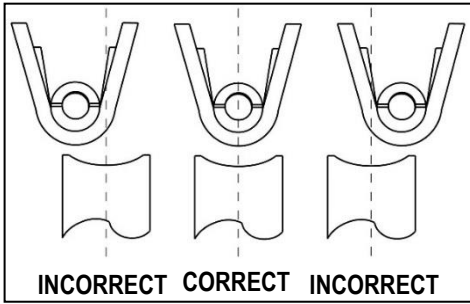

**Feed Adjustment: Air Feed Applicators**

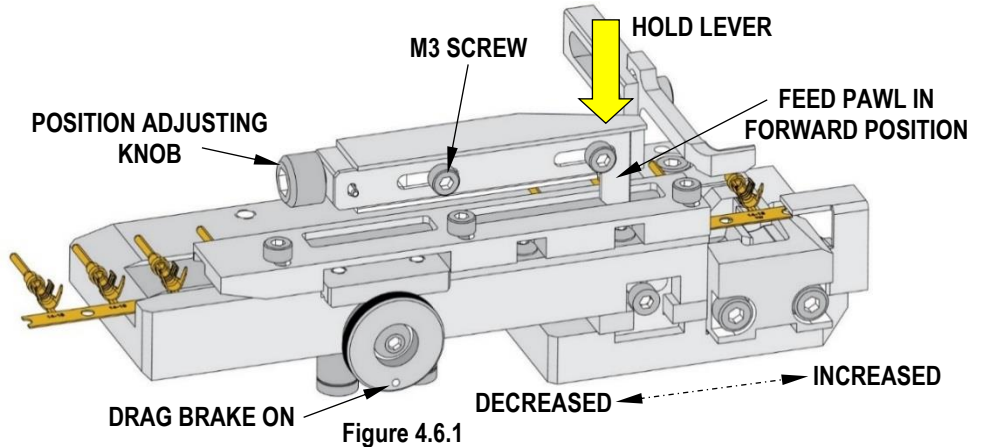

Air feed applicators use an air cylinder to push terminals through the applicator track. The back stroke of the feed cycle is adjusted to the specific terminal pitch. The air cylinder stops at the same forward position for all terminals, but the forward position of the feed pawl is adjustable to center the terminal exactly over the crimp anvils using the position adjusting knob.

**Air Feed Forward-Stroke Adjustment**

**Note:** For air feed applicators, the forward-feed position of the feed cycle should be adjusted before the back-feed position.



**Caution:** Always disconnect press power before installing or removing tooling.

**Caution:** DO NOT operate the applicator without guards in place.

1. Disconnect power to the press. Load terminals in the track, and make sure the drag brake is on (dot facing down).
2. Operate the press air valve to feed the terminal over the anvils (feed pawl forward).
3. While holding the feed pawl lever down (this keeps the lever from jumping up), loosen the two M3 screws on the feed pawl about one turn each.
4. Turn the position adjusting knob clockwise (left to right) to increase feed position or counterclockwise (right to left) to decrease position. See Figure 4.6.2. When decreasing position, the terminal strip needs to be pulled back against the feed pawl to observe the change.
5. Tighten the M3 screws to lock the feed pawl in position.
6. Turn the press air valve on and off. Check the forward feed position.

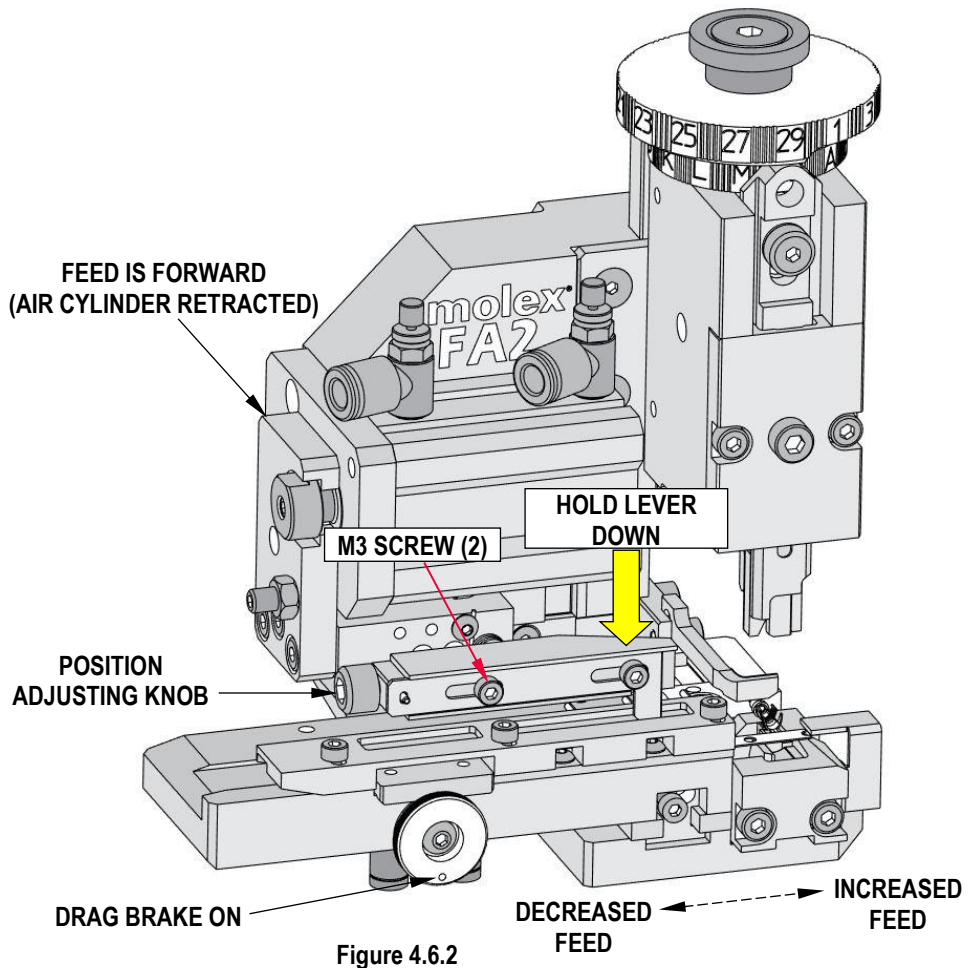

## Air Feed Back-Stroke Adjustment

After adjusting the forward stroke of the feed cycle, follow these steps to adjust the back-stroke position of the feed cycle. See Figure 4.6.3.

1. Load terminals in the track, and make sure the drag brake is on (dot facing down).
2. Activate the press air valve to move the feed pawl forward (air cylinder retracted). Ensure that the terminal is centered over the anvils.
3. Activate the press valve to move the feed pawl back (air cylinder extended).
4. Observe the feed pawl position to the terminal carrier strip pilot hole, and determine which direction to adjust the back-stroke feed position.
5. To adjust the back-stroke feed position, loosen the lock nut with an 8mm wrench. Use a 2.5mm hex wrench to turn the adjusting screw clockwise to increase the back-stroke or counterclockwise to reduce the back-stroke.
6. Make sure the back-stroke adjustment allows the feed pawl to drop into the terminal carrier strip pilot hole. If adjusted too far back, the feed pawl may not engage the terminal carrier strip pilot hole when feeding forward.
7. When the adjustment is complete, hold the adjusting screw with a 2.5mm hex wrench and tighten the lock nut.

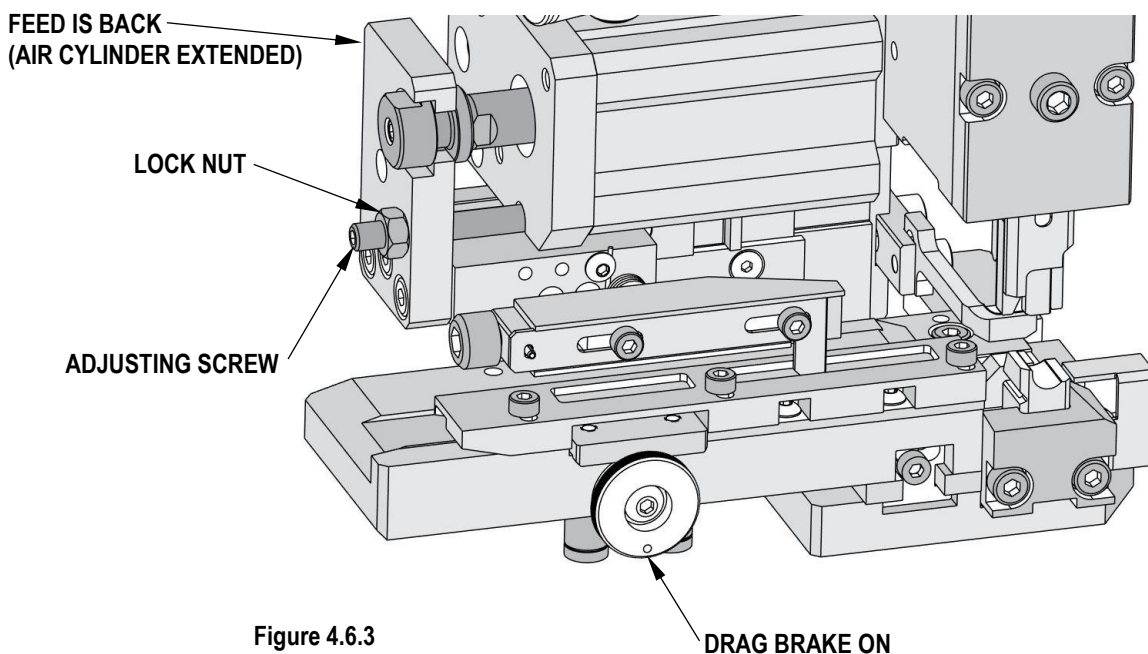

Figure 4.6.3

### Air Feed Operation Notes

1. The air feed cylinder operates with dry or lubricated air. Any water vapor in the air supply will reduce cylinder life.
2. The air feed applicator should be operated with 70-145 psi (4.8-10 bar) air pressure.
3. Speed controls on the feed cylinder may be adjusted, but if the feed runs too fast, there may be terminal feed position errors.
4. The air feed is not intended to pull the weight of a terminal reel. Keeping a slack loop of terminals between the reel and the applicator track will minimize feed problems.

## 4.7 Terminal Track Position Adjustment

The terminal track should be adjusted only to correct the size of crimp bellmouth and terminal cut-off tab. A 2.5mm hex wrench is used for adjustment.



**Caution: Always disconnect press power before installing or removing tooling.**



**Caution: DO NOT** operate the applicator without guards in place

1. Disconnect power to the press. Remove machine guards if necessary.
2. Raise the feed pawl out of the guide groove, and rest it on top of the feed pawl guide. This prevents damage to the feed pawl during track adjustment. See Figure 4.7.1.

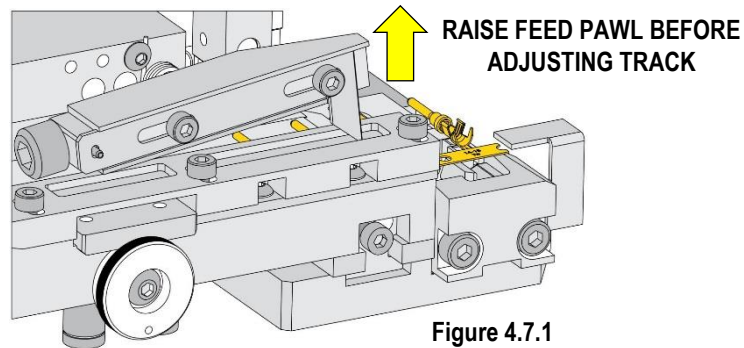

Figure 4.7.1

3. Loosen the track locking screw 2 turns. See Figure 4.7.2.

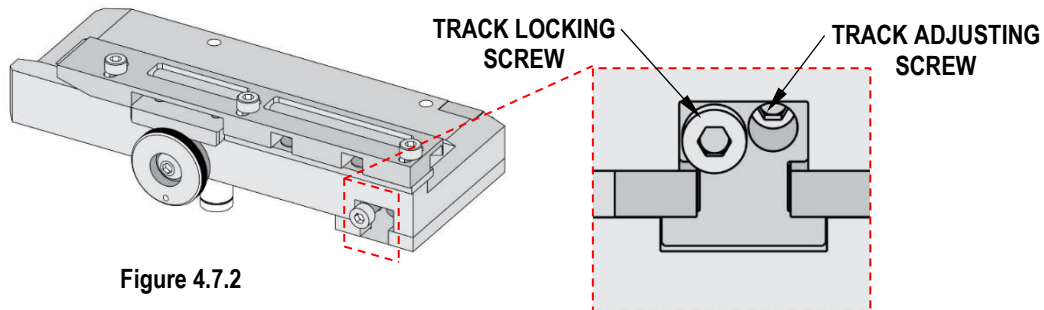

Figure 4.7.2

4. Turn the track adjusting screw in the direction needed (one revolution of the screw moves the track 0.8mm or .031"):
  - a. Turn clockwise to move the track in (away from the operator). This adjustment increases the cut-off tab length and decreases the bellmouth size.
  - b. Turn counterclockwise to move the track out (toward the operator). This adjustment decreases the cut-off tab length and increases the bellmouth size.

**Note:** If the track is adjusted out too far, the terminal will interfere with the front cut-off plunger and cause terminal feed problems.

- c. Make adjustments in small increments ( $\frac{1}{4}$  to  $\frac{1}{2}$  turn).
5. Tighten the track locking screw until snug. Do not overtighten the screw—about 0.5 N-m (5 in.-lb.) is enough to lock the track.
6. Raise the feed pawl and put it back in the guide groove of the feed pawl guide. Make sure the feed pawl is engaging the terminal carrier strip pilot hole.
7. Restore power to the press, crimp a terminal under power and inspect crimp bellmouth and cut-off tab.
8. Repeat the above steps until the desired cut-off tab or bellmouth is obtained.

## 4.8 Crimp Tooling Installation and Removal

### Removal and Installation of Upper Tooling (Punches)



**Caution:** Always disconnect press power before installing or removing tooling.



**Caution:** DO NOT operate the applicator without guards in place.

### Upper Tooling Removal

1. Disconnect power to the press.
2. Remove machine guards if necessary.
3. Remove the two M4 screws from the punch cover on the ram.
4. Remove the punch cover, and remove the punches. See Figure 4.8.1.

**Note:** Some applicators have spring-loaded stuffers mounted between the insulation punch and front striker or between the conductor and insulation punches. Make sure this tooling stays together.

### Upper Tooling Installation

**Note:** Always clean the mounting surfaces of crimp punches, other upper tooling and the ram pocket before installation.

Reverse the previous steps to install the punches. The punches can be inserted in only one direction, but they must be installed in the correct order: conductor punch, conductor stuffer (if present), insulation punch and punch cover. The part number markings on the punches must face the operator. See Figure 4.8.2.

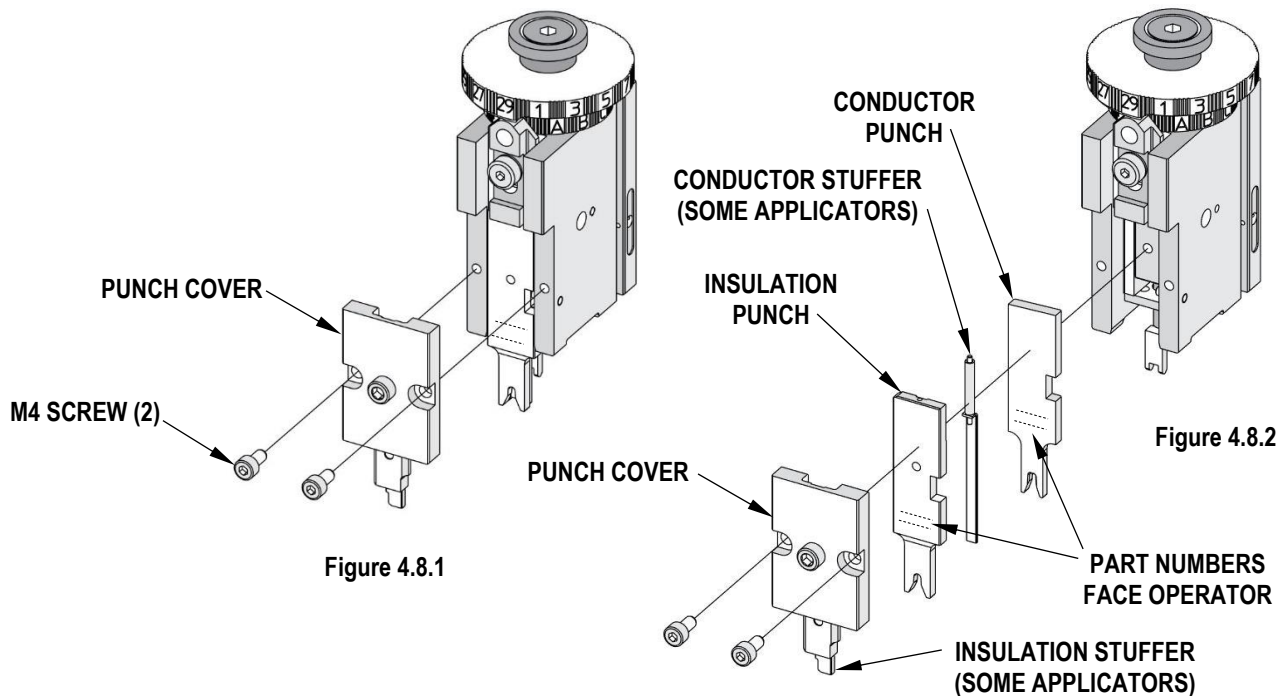

## Upper Tooling Alignment

Upper tooling is mounted in a precision-machined pocket and should not require further alignment. However, it is a good practice to hand-cycle the applicator after installing the upper tooling to ensure correct fit.

**Note:** If the punches or anvils are installed in the incorrect order or are incorrectly matched, there will be a tooling crash.

## Removal and Installation of Lower Tooling (Anvils)



**Caution:** Always disconnect press power before installing or removing tooling.



**Caution:** DO NOT operate the applicator without guards in place.

## Lower Tooling Removal

1. Disconnect power to the press. Remove machine guards if necessary.
2. Make sure the applicator ram is all the way up.
3. Remove the two M4 screws that are holding the lower tooling in place, and pull out the tooling. See Figure 4.8.3.
  - **Note:** Do not remove the mounting datum.

## Lower Tooling Installation

**Note:** Always clean the mounting surfaces of crimp tooling, spacers and mounting datum before installation.

1. Install spacers in the proper order (see the specific ATS document for part location). The part number marking on each spacer must face the operator.
2. Install anvils in the proper order (see the specific ATS document for part location). The part number marking on each anvil must face the operator. See Figure 4.8.3.
3. Install the cut-off plunger, cut-off retainer and cut-off plunger spring.
4. While holding the cut-off plunger down, install the two M4 screws and tighten.
5. Push down on the cut-off plunger and make sure it returns to the up position. If the cut-off plunger motion binds, it may be caused by M4 screws that were overtightened or something that is not parallel (e.g., possible debris) between the anvil and spacer stack.

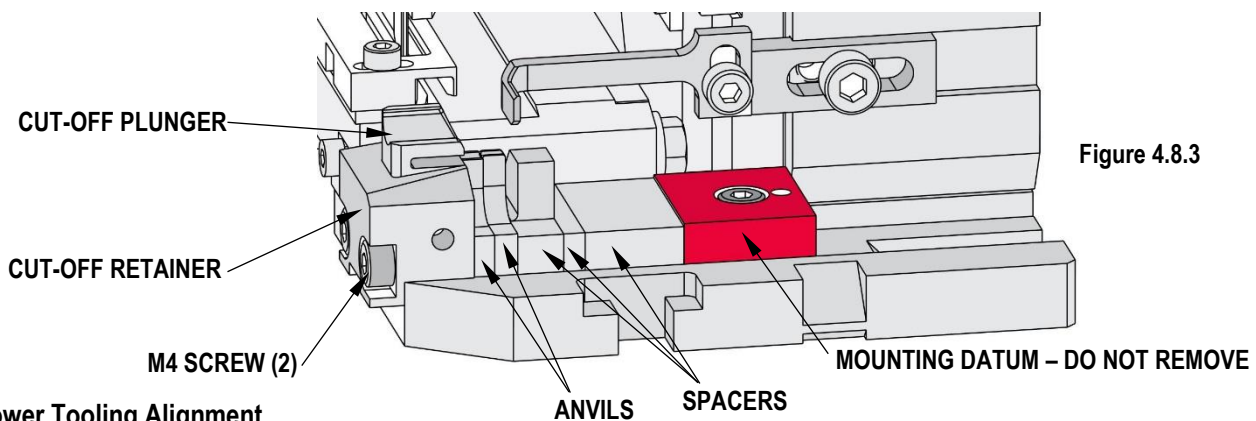

## Lower Tooling Alignment

Lower tooling is mounted in a precision-machined pocket and should not require further alignment. However, it is a good practice to hand-cycle the applicator after installing the lower tooling to ensure correct fit.

**Note:** If the punches or anvils are installed in the incorrect order or are incorrectly matched, there will be a tooling crash.



## 4.9 Wire Stop Setup and Adjustment

For automatic wire processing machines, the wire stop can be used to assist in stripping the terminal from the punches. However, in certain circumstances, the wire stop may need to be removed when running on an automated machine.

### Wire Stop Setup



**Caution:** Always disconnect press power before installing or removing tooling.



**Caution:** DO NOT operate the applicator without guards in place.

For initial wire stop positioning, follow this procedure:

1. Disconnect power to the press.
2. Remove the applicator from the press.
3. Install the ram storage screw partway.
4. Lower the applicator ram. As it approaches the bottom of travel, finish installing the ram storage screw. When properly installed, the screw prevents the ram from falling too far (preventing tooling damage) and prevents the ram from being unintentionally pulled out of the applicator frame. See Figure 4.9.1.

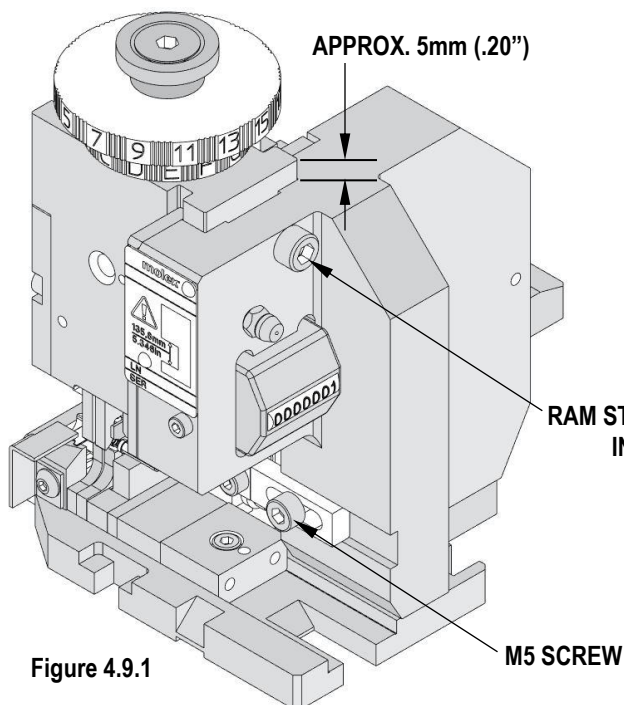

Figure 4.9.1

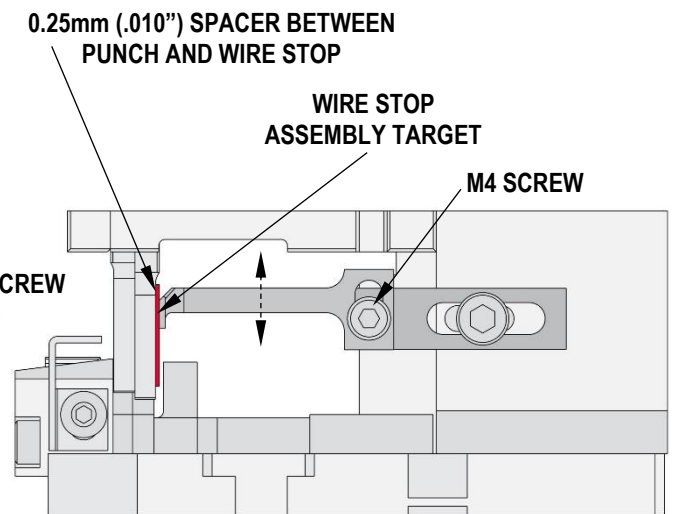

Figure 4.9.2

5. Use a 4mm hex wrench to loosen the M5 screw on the side of the applicator frame. See Figure 4.9.1.
6. Move the wire stop assembly away from the conductor punch.
7. Use a 3mm hex wrench to loosen the M4 screw on the wire stop assembly mount. See Figure 4.9.2
8. Adjust the wire stop assembly target up or down so terminals can feed freely under it. Tighten the M4 screw.
9. While holding a 0.25mm (.010") spacer behind the conductor punch, move the wire stop assembly toward the conductor punch until the wire stop target touches the spacer. See Figure 4.9.2.

**Note:** The spacer can be any of the following:

- Metal or plastic shim stock
- Terminal carrier strip
- Several sheets of paper

10. While holding the wire stop assembly against the spacer, tighten the M5 screw on the side of the applicator frame.
11. Remove the spacer from the applicator and discard.

**Wire Stop Adjustment**

Use the following steps to determine if a wire stop adjustment is necessary:

1. Review the appropriate ATS document for the applicator to find the correct wire brush length.
2. Crimp the wire to the terminal under power.
3. Inspect wire brush length. See Figure 4.9.3.

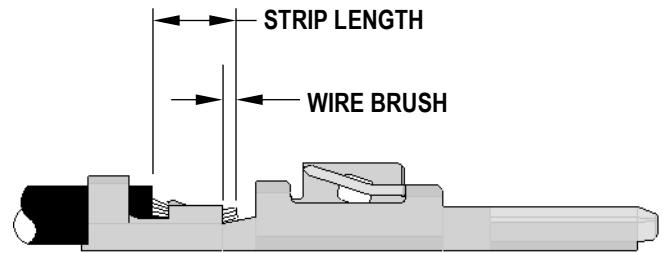

Figure 4.9.3

If an adjustment is necessary:



**Caution: Always disconnect press power before installing or removing tooling.**



**Caution: DO NOT operate the applicator without guards in place.**

1. Disconnect power to the press. Remove machine guards if necessary.
2. Use a 4mm hex wrench to loosen the M5 screw on the side of the applicator frame.
3. Adjust brush length by moving the wire stop assembly as follows (See Figure 4.9.4):
  - **Decrease brush length:** Move the wire stop assembly toward the operator.
  - **Increase brush length:** Move the wire stop assembly away from the operator.
    - **Note:** When decreasing brush length, be aware that the conductor punch can hit the wire stop assembly target if the wire stop assembly is adjusted too far forward (toward the operator). Hand-cycle the press to ensure that there is no crash condition between the wire stop assembly and the upper tooling and that the terminals feed properly beneath it.
4. Tighten the M5 screw.
5. The M4 screw on the wire stop assembly is used when raising or lowering the wire stop assembly target. The wire stop assembly must be high enough for terminals to feed under it.
6. Hand-cycle the press to ensure that there is no crash condition between the wire stop assembly and the upper tooling and that the terminals feed properly beneath it.
7. Crimp a terminal under power, and inspect the change in brush length.

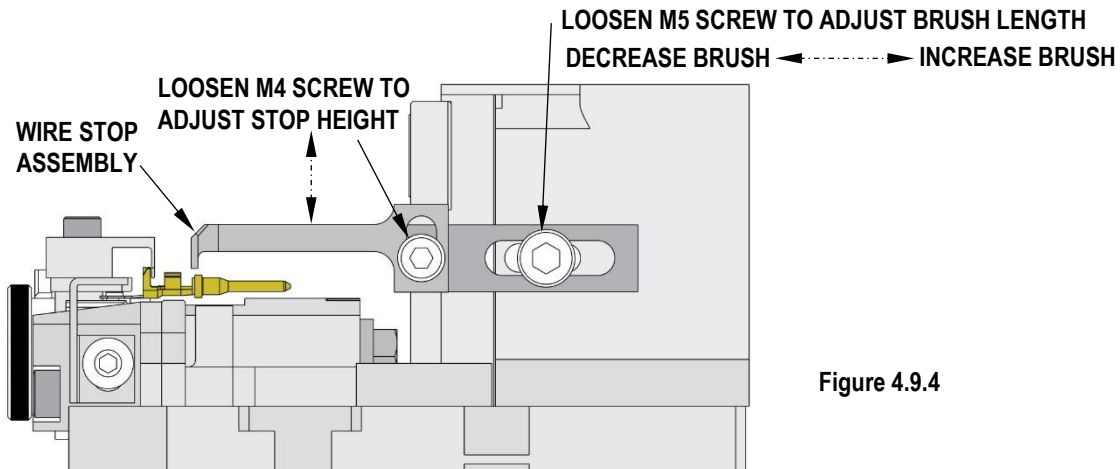

Figure 4.9.4

## 4.10 Wire Processing Setup and Feed Cam Orientation

### Setup for Wire Processing

There are several adjustments that may be needed if the applicator is to be used in a fully automatic wire processor. Molex applicators are typically set up at the factory for benchtop application. The following information pertains to applicator use in automatic wire processors only:

- The feed cam position may need to be flipped to post-feed timing.
- The terminal forward feed position should be verified on the wire processor in case the change in press speed affects the crimp symmetry.
- It is a common practice to remove the scrap shield and wire stop.
  - Rather than removing these parts, Molex recommends making adjustments to these parts if they are causing interference. The wire stop also acts as a terminal stripper, helping to remove the crimped terminal from the punch. In most cases, adjusting the vertical height will provide the clearance needed in wire processing.
  - If the wire stop must be removed from the workspace, then it can be flipped around and mounted backward in its location to prevent its loss.
- Many of the FA2 applicators have a cut-off retainer where the cutting insert can be removed to allow the wire processor to chop the scrap carrier strip.
- At the completion of a job, it is recommended that applicators are checked for lubrication and potential tooling wear to expedite future installation.

### Feed Cam Orientation

1. The terminal feed stroke is driven by a cam mounted to the applicator ram. The cam is compatible with press strokes between 28.6-41.3mm (1 1/8-1 5/8").
  - **Note:** Using the applicator in a press with a stroke outside of this range may result in insufficient feed stroke or incorrect feed timing.
2. Determine what feed timing is required. See Figure 4.10.1.

Timing	Best Use	Description
Pre-Feed Timing	Bench Crimping	Terminal feeds as ram goes up
Post-Feed Timing	Wire Processing Machines	Terminal feeds as ram goes down

- **Note:** The applicator is shipped with the cam mounted for pre-feed timing.



**Caution: Always disconnect press power before installing or removing tooling.**



**Caution: DO NOT operate the applicator without guards in place.**

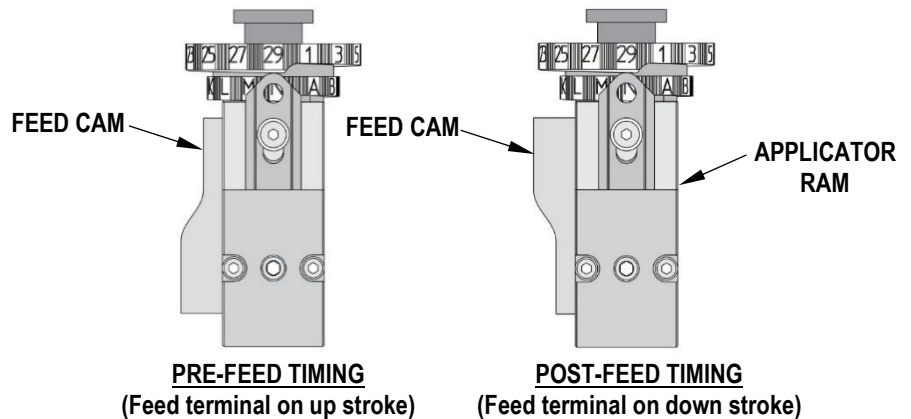

Figure 4.10.1

3. Disconnect power to the press. Remove machine guards if necessary.
4. Remove the terminals from the applicator, and remove the applicator from the press.
5. Push the feed pawl slide toward the ram so the feed pivot lever is vertical, and lift the ram to remove it from the applicator. See Figure 4.10.2.
6. Use a 3mm hex wrench to remove the two M4 screws holding the cam to the ram. See Figure 4.10.3.

7. Position the cam in the desired orientation for feeding, and reinstall the M4 screws.
8. Push the feed pawl slide toward the ram so the feed pivot lever is vertical, and install the ram in the applicator.

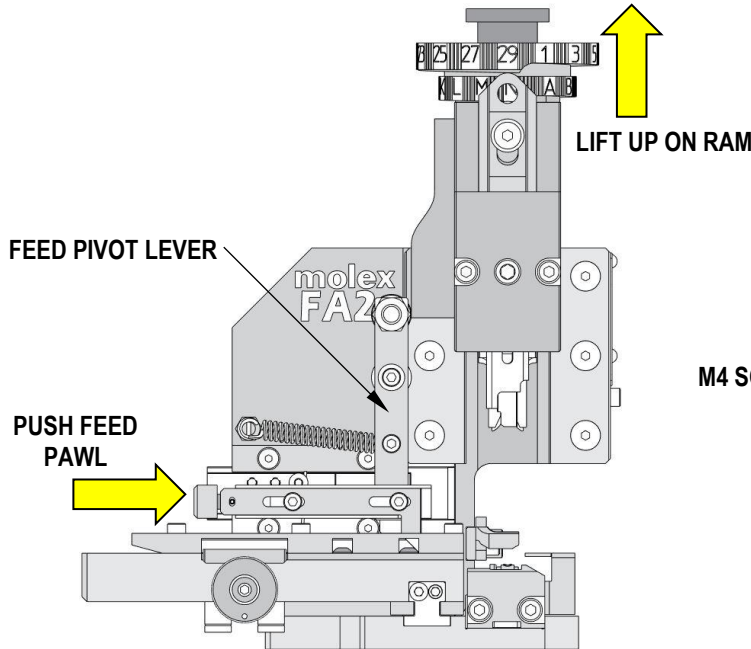
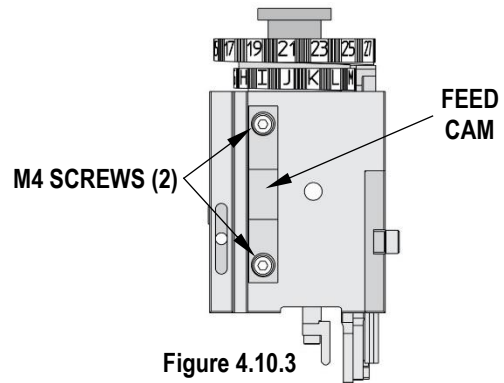

Figure 4.10.2



### 4.11 Bend Adjust Dial

Some applicators have a bend adjust dial on the side of the ram. See Figure 4.11.1. This dial precisely adjusts the nose hold down tool to control terminal straightness (bend up or bend down) during crimping.

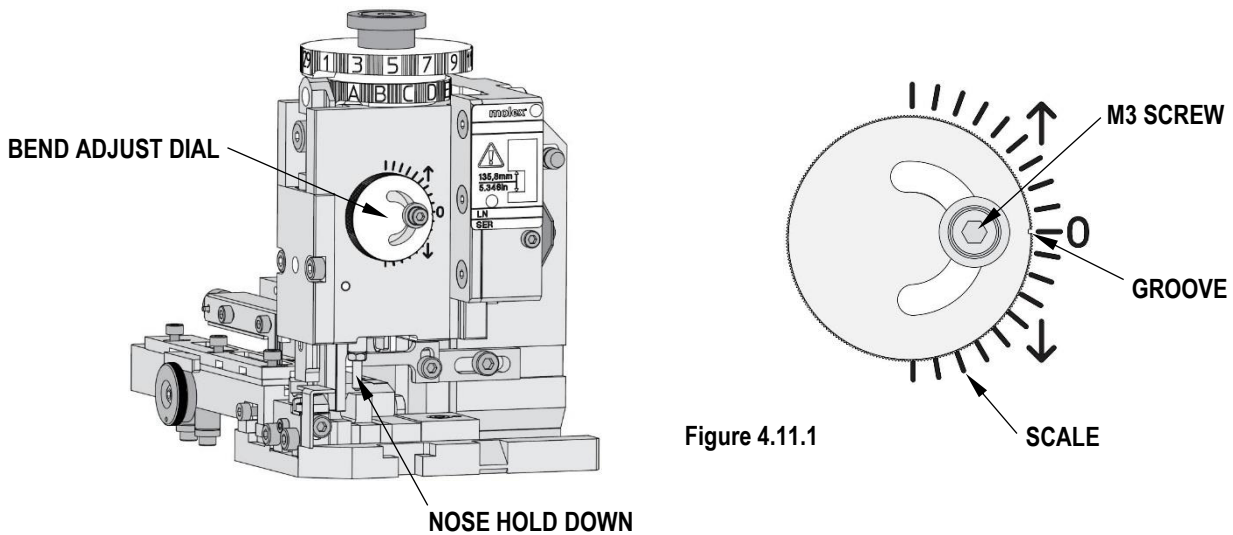

Figure 4.11.1

To adjust the dial, loosen the M3 screw and turn the dial. There is an indicator groove in the dial and a scale on the ram. Although the scale is for reference, turning the dial clockwise lowers the nose hold down, and turning it counterclockwise raises the nose hold down. Make adjustments in small increments.

Tighten the M3 screw before operating the applicator.

**NOTE:** If applicator is installed in a press with automatic shut height adjustment, crimp height should be established first, then make dial adjustments.

## Section 5 – Maintenance

### 5.1 Cleaning



**Caution: Disconnect press power before installing or removing tooling.**

For reliable operation, the applicator should be cleaned daily. Use a soft bristle brush to remove debris from critical areas such as the upper and lower crimp tooling and the terminal track. For best results, remove the crimp tooling from the press. Brush and then use a clean cloth to wipe off the upper and lower tooling mounting areas. Before reinstalling the tooling, wipe all sides of the punches and anvils with a clean cloth.

**DO NOT USE COMPRESSED AIR TO CLEAN THE APPLICATOR.**

### 5.2 Lubrication



**Caution: Disconnect press power before all maintenance.**

1. The grease fitting on the back of the applicator is for ram lubrication. The ram is greased while the ram is up. This can be done while the applicator is mounted in the press. If greasing on the workbench, move the ram up by hand and install the ram storage screw so it enters the lower storage hole. See Figure 5.2.1.

✦ Newer FA2 applicators don't have grease fitting.

2. Grease the ram with a multipurpose synthetic lubricant with Teflon or an equivalent. If using a grease gun, stop when the grease begins to show at the top of the applicator frame.

3. For newer FA2 applicators without grease fitting, use a brush to apply grease to ram surfaces shown in Figure 5.2.2.

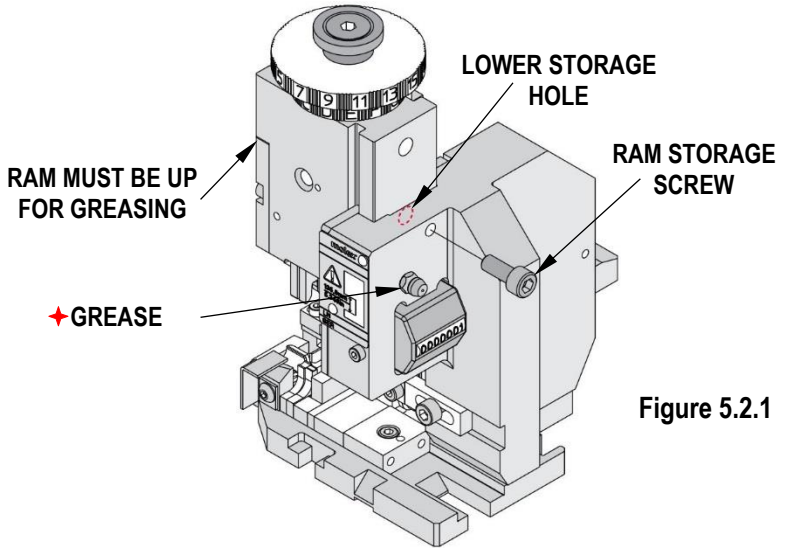

Figure 5.2.1

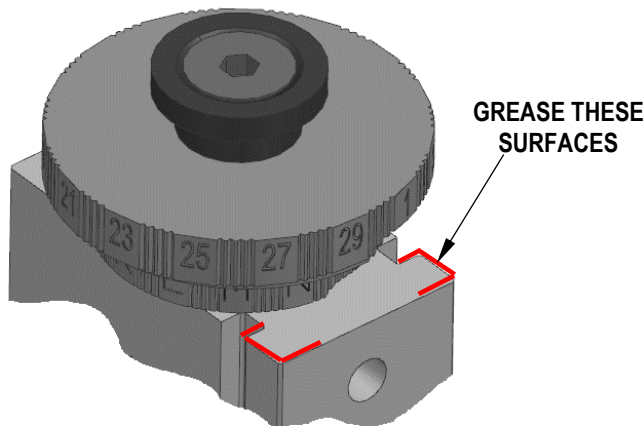

Figure 5.2.2

Molex ships applicators greased with Synco® Super Lube® Multi-Purpose Synthetic Grease with PTFE (Synco® part number 41150)

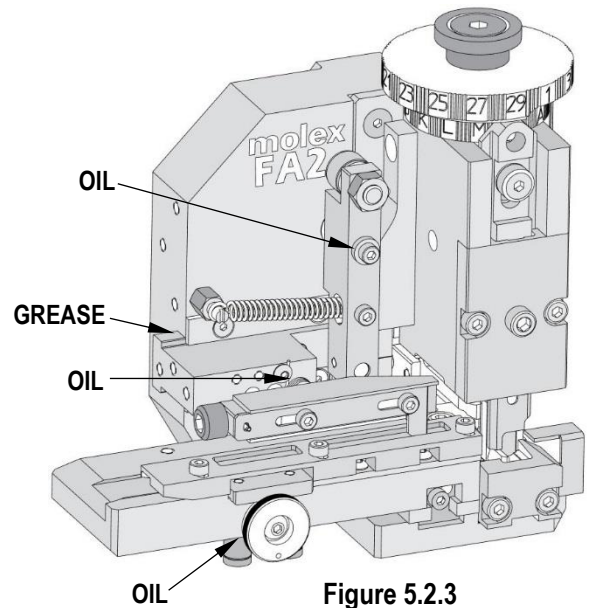

Figure 5.2.3

4. Additional lubrication areas are shown in Figure 5.2.3.
  - **Oil:** Spindle oil, 3-in-One® Oil or equivalent
  - **Grease:** Synco® 41150 or equivalent

5. Frequency of lubrication depends on the use of the applicator. An applicator run daily in an automatic wire processor should be lubricated at least twice per month. Applicators used for occasional bench crimping can be lubricated twice per year. The applicator should be lubricated before storage.



**WARNING:** Never use penetrants (such as WD-40®) for any lubrication on the applicator.

### 5.3 Storage

To prevent crashing tooling during applicator storage or transport, a plastic ram storage screw is provided in the applicator's back frame. There is a corresponding storage hole in the ram to accept this screw. When installed, the ram storage screw will hold the ram from falling down (and from accidentally being pulled out). See Figure 5.2.1.

If the ram storage screw is missing, leave a strip of terminals in the applicator (with a terminal positioned over the crimp anvils), or place wood or rubber between the upper and lower tooling to prevent damage.

## Section 6 – Service Parts

### Basic Applicator

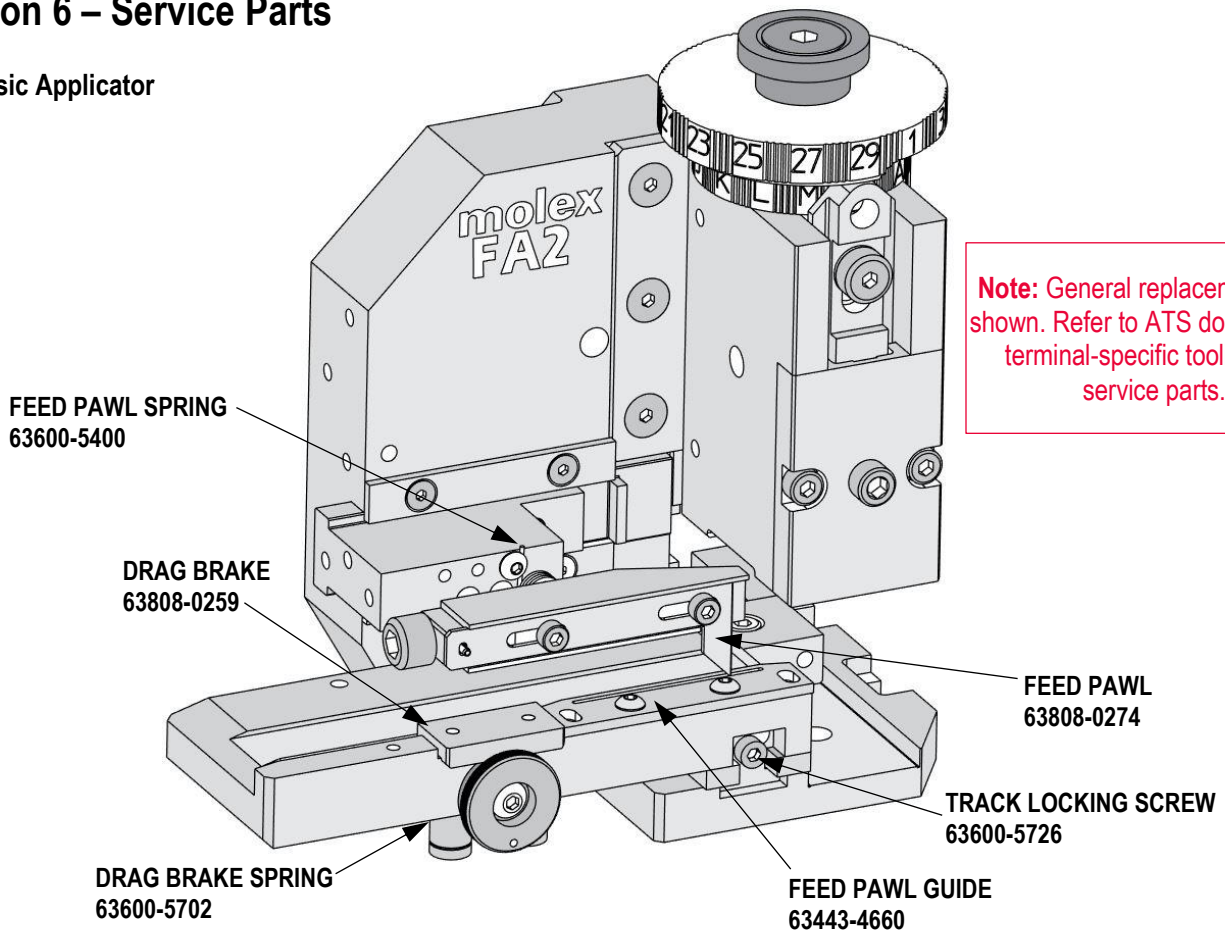

**Note:** General replacement parts shown. Refer to ATS document for terminal-specific tooling and service parts.

### Mechanical Feed

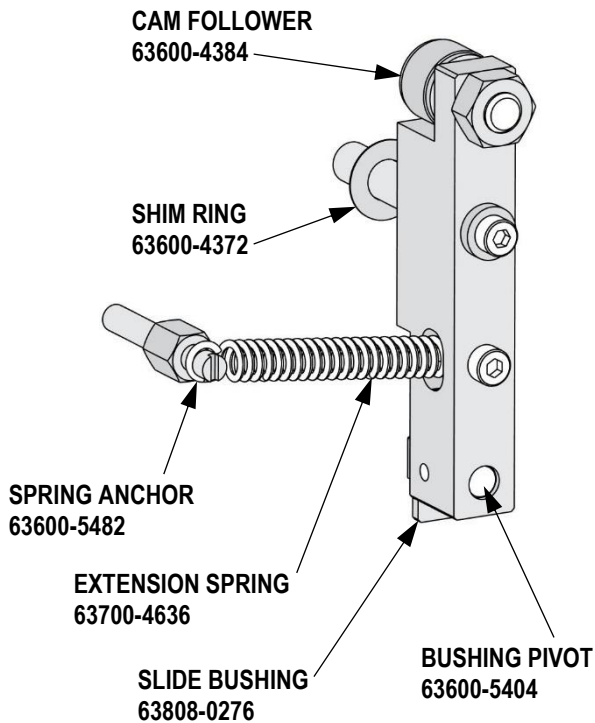

### Air Feed

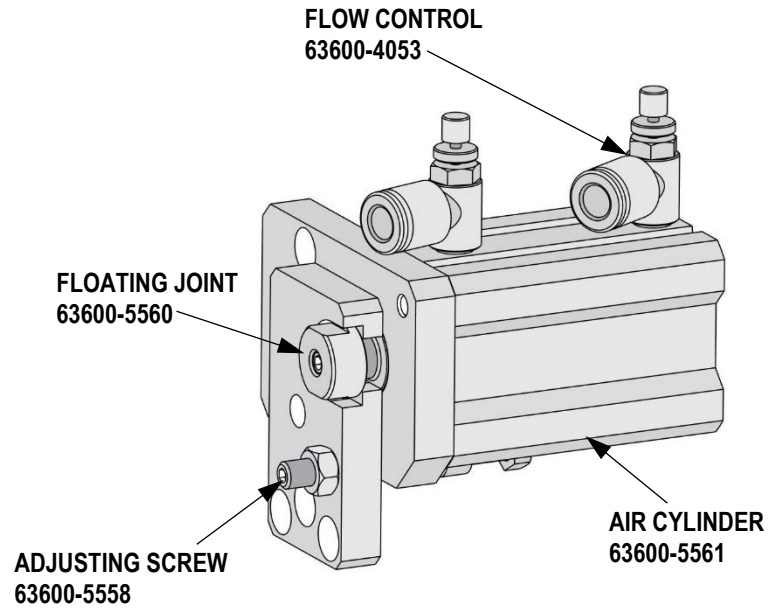

## 6.1 Feed Pawl Spring Replacement

The applicator must be removed from the press for this procedure.

1. For mechanical feed applicators, remove the ram from the applicator.
2. For air feed applicators, extend the air cylinder.
3. On the bottom of the base plate, use a 3mm hex wrench to remove the two M4 track mounting screws. See Figure 6.1.1.
4. While holding the feed pawl up, slide the track assembly out of the applicator.
5. Pull off the feed pawl assembly and feed pawl spring.
6. Use a 2mm hex wrench to loosen the M3 screw holding the spring to the feed arm. See Figure 6.1.3.
7. Discard the used spring.
8. Install the new spring over the feed pawl shaft, and make sure the leg of the spring is resting on top of the M3 screw. Use a 2mm hex wrench to tighten the M3 screw. Do not overtighten. See Figure 6.1.3.
9. **Note: Apply a few drops of oil on the shaft before installing.**
10. Install the feed pawl assembly. When approaching the guide block, make sure the leg of the spring goes on the right side of the set screw. See Figure 6.1.4.
11. While holding the feed pawl up, install the track assembly and tighten its two M4 screws. See Section 4.7.

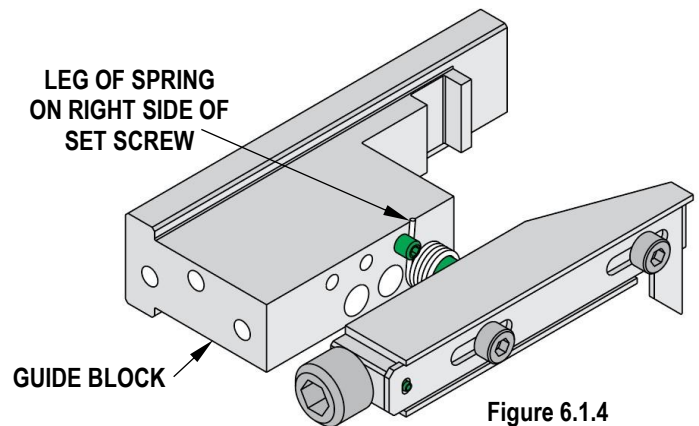
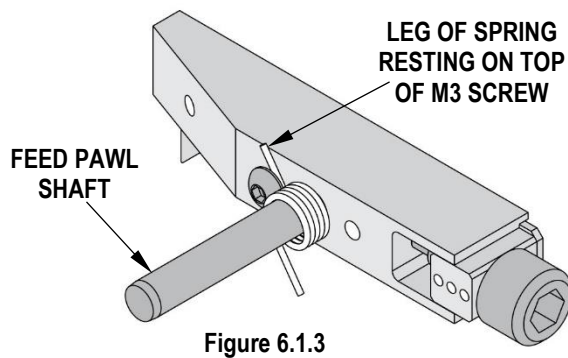
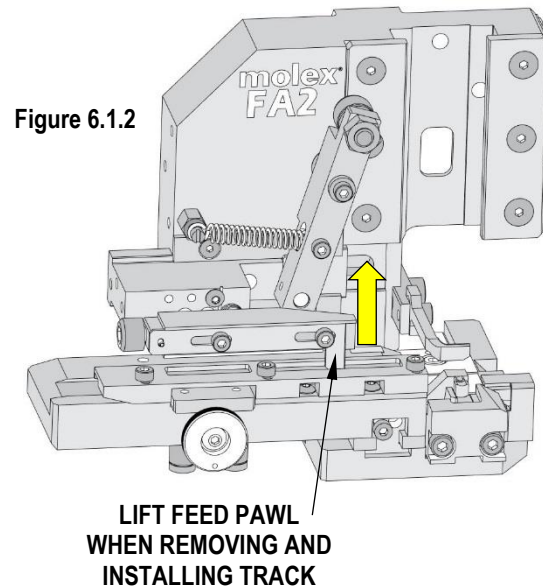
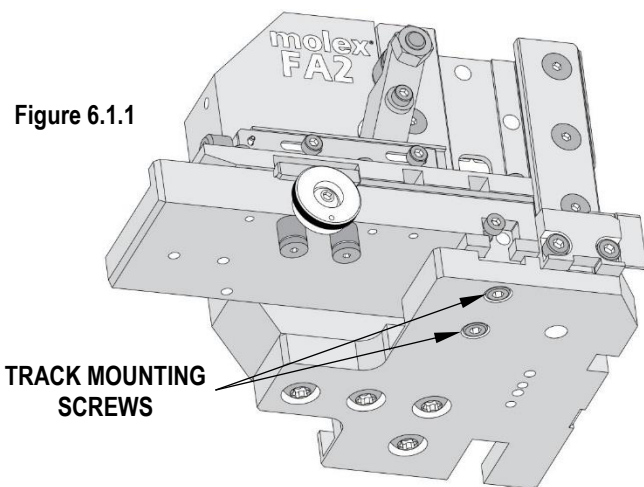



## 6.2 Accessories

For terminals that require lubrication for crimping, terminal oiler 63801-7240 is available. See document ATS-638017240 for more details.

## 6.3 Contact Us

### Application Tooling Support

**Phone:** (402) 458-TOOL (8665)

**E-Mail:** [toolingsupport@molex.com](mailto:toolingsupport@molex.com)

**Website:** [www.molex.com/applicationtooling](http://www.molex.com/applicationtooling)

## Section 7 – Crimp Quality

For more information, use the Quality Crimping Handbook.

This handbook can be downloaded from the Molex website ([www.molex.com](http://www.molex.com)), or contact your local Molex sales engineer.

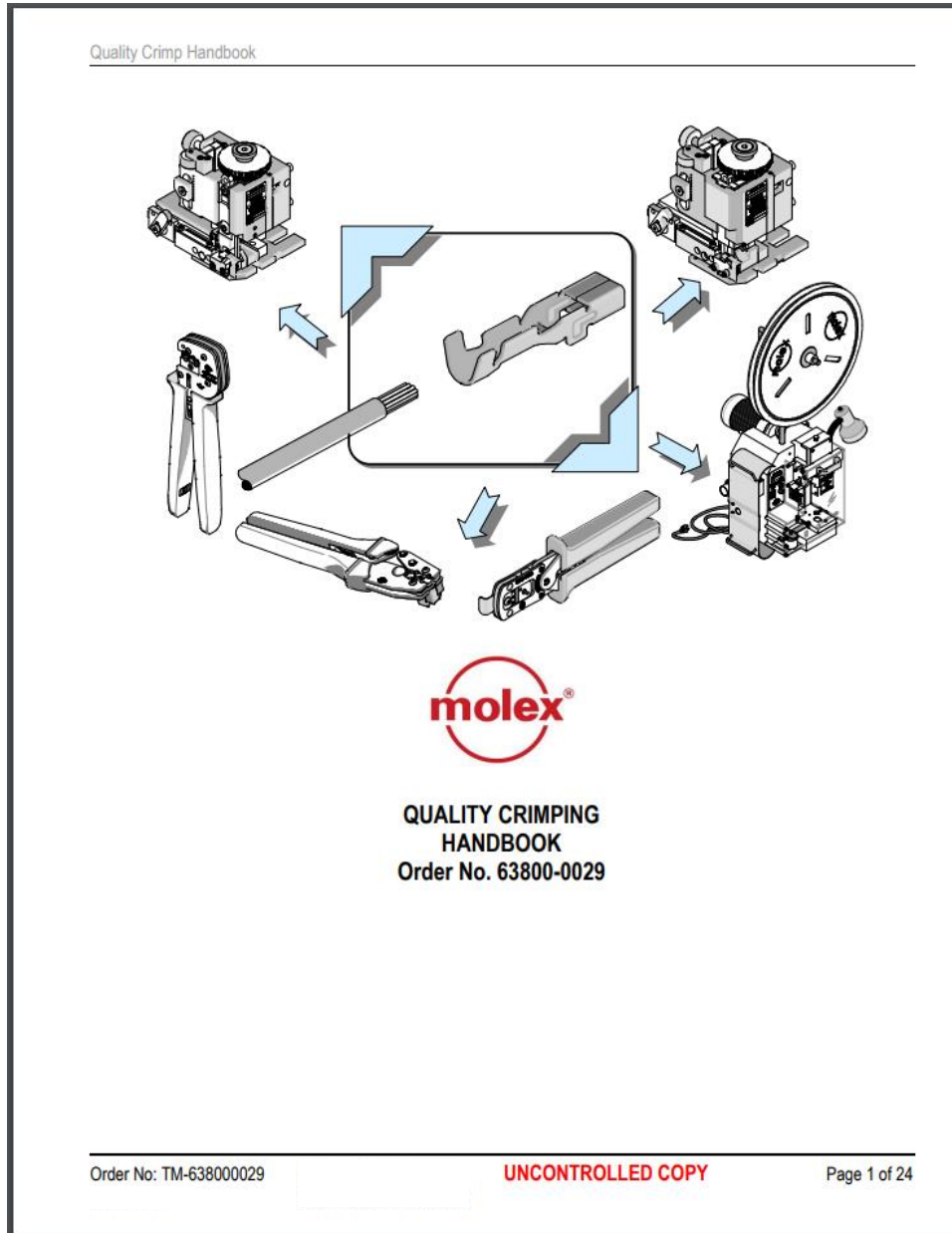

Molex is a registered trademark of Molex, LLC in the United States of America and may be registered in other countries; all other trademarks listed herein belong to their respective owners.