



Keywords: ultrasound receiver and transceiver, analog-to-digital converter (ADC), signal-to-noise ratio (SNR)

APPLICATION NOTE 5765

MAXIMIZE THE PERFORMANCE OF HIGH-SIGNAL-TO-NOISE RATIO (SNR) ULTRASOUND RECEIVERS WITH AN OPTIMIZED SYSTEM DESIGN

By: John Scampini, Executive Director in the Industrial Communications and Ultrasound Business Unit

Abstract: The current generation of ultrasound receivers and transceivers, like the MAX2082 have been optimized for superior SNR performance. Advancements in low-power, high-resolution analog-to-digital converters (ADCs) and low-output-noise variable-gain amplifiers (VGAs) have made these advancements possible. To take advantage of this improved receiver performance, however, it is necessary for the designers to understand how the gain settings in these devices, as well as the dynamic range, filtering, detection, and display mapping of the received data, must be properly optimized. The purpose of this application note is to review these topics in sufficient detail so the reader can better optimize their systems and take advantage of these improved devices.

A similar version of this article appears on [EDN](#), November 7, 2013.

Introduction

In recent years, the signal-to-noise ratio (SNR) performance of ultrasound receivers has improved significantly. Advances are tied to low-power ADC technology that has allowed users to migrate from 10- to 12-bit and higher ADCs. Meanwhile, low output-referred-noise variable-gain amplifiers (VGAs) are designed to take advantage of these ADCs. When these new ADCs and VGAs are integrated into ultrasound receivers, the SNR significantly improves. The new high-SNR receivers have been generally accepted and systems can now support significantly improved B-mode harmonic imaging and pulsed-mode Doppler performance.

To optimize the SNR, changes in the gain range of these new ultrasound receivers is required. This then causes problems for some users accustomed to older, lower-SNR receiver designs.

This application note explains how receiver gain is determined, and how the receiver gain settings can negatively impact receiver SNR when they are set too high. It also discusses how to properly optimize the dynamic range of the digital beamformer, filter, detector, and compression signal mapping. Once this is done, your system will maximize the performance offered by high-SNR receivers, resulting in significantly improved diagnostic performance.

Calculating Ultrasound Receiver Gain

A typical high-performance ultrasound receiver lineup is shown in **Figure 1**. It consists of a low-noise amplifier (LNA), VGA, anti-alias filter (AAF), and ADC. The LNA buffers the incoming signal and provides sufficient gain to overcome the noise of the subsequent stages. In a properly designed receiver the noise performance of the LNA largely determines the noise performance of the full receiver lineup. The VGA stage provides the necessary variable-time gain control to map the large input signal's dynamic range into the more limited dynamic range of the ADC. The AAF provides the necessary filtering to ensure that out-of-band noise and signals are not aliased into the signal band and, thus, do not corrupt receiver performance.

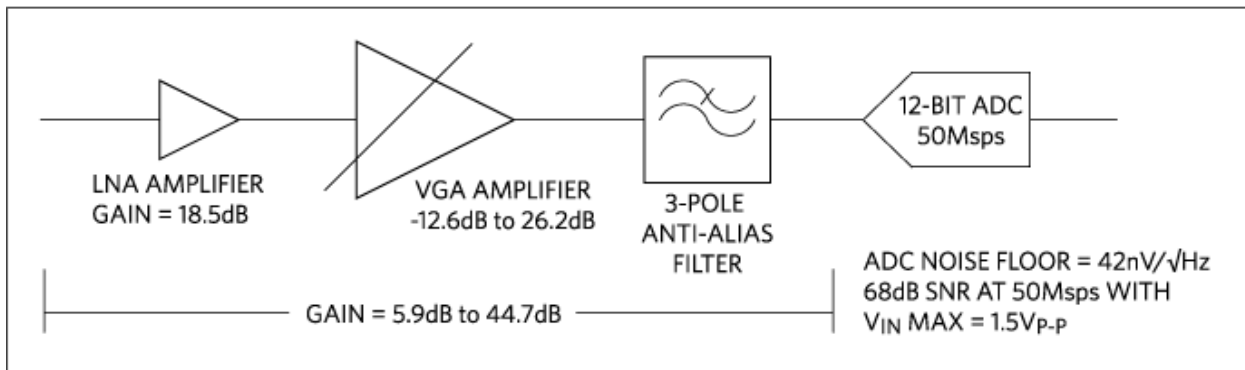

Figure 1. A typical ultrasound receiver path block diagram. This example is from the MAX2082 octal ultrasound transceiver.

Figure 1 shows that the maximum and minimum gains of the receiver are 44.7dB and 5.9dB, respectively. The question to ask now is how were these gains selected?

The minimum gain of the receiver was selected to ensure that the largest allowable LNA input signal would not saturate the ADC in the near field. With the MAX2082 receiver, the maximum input signal with the LNA gain at 18.5dB is 330mV_{P-P}. The maximum input range of the 12-bit ADC is 1.5V_{P-P}. As a result, the minimum receiver gain needs to be no greater than $20 \times \log(1.5/0.33)$ or about 13.2dB. For the MAX2082, the minimum gain is actually 5.9dB, which provides an additional 7.3dB of margin.

The maximum receiver gain was selected to ensure that the combined output noise contribution of the VGA, AAF, and ADC circuits would not significantly corrupt its noise figure. To ensure that this does not happen, the receiver output noise at maximum gain must be at least 10dB greater than the combined noise contribution of these sources. The 10dB number is a generally accepted “good practice” rule. When met, the noise contribution from the VGA, AAF, and ADC reduces the receiver noise figure by typically less than 0.25dB, which is generally considered acceptable. **Figure 2** shows the output noise of the MAX2082 receiver versus gain.

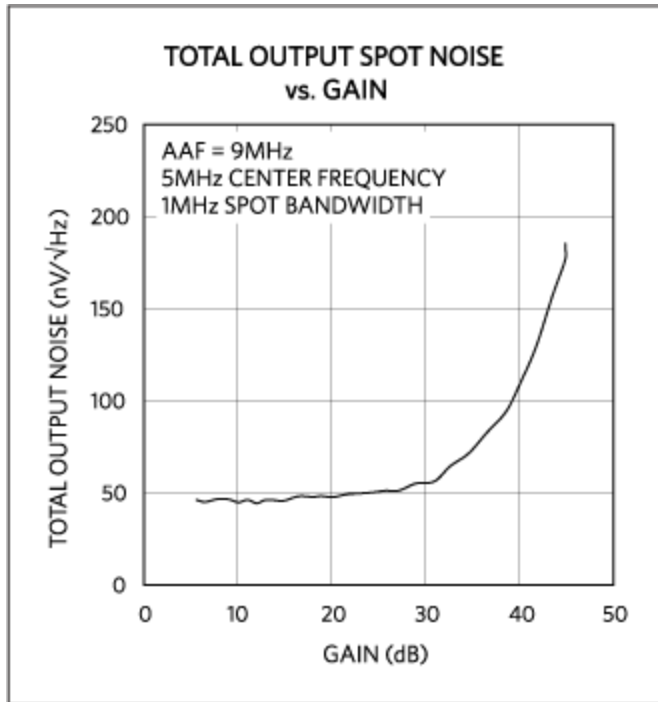

Figure 2. MAX2082 total output noise vs. gain.

Figure 2 shows that the receiver noise floor in the MAX2082 transceiver at low gains is about 50nV/ Rt. This noise is the output noise contribution of the 12-bit ADC, VGA, and AAF. In a well-designed receiver the ADC should dominate this noise. In the MAX2082, the ADC has a noise floor of approximately 42nV/ Rt; the noise contribution of the circuitry before the ADC is small, given that the total output noise is 50nV/ Rt. Assuming a 200 transducer source impedance and 200 termination impedance for the receiver, then the input-referred noise is about 1.0nV/ Rt. As a result, the maximum receiver gain needs to be at least $20 \times \log(50/1) + 10\text{dB}$, or about 44dB. The maximum gain for the MAX2082 was chosen to be 44.7dB and the transceiver meets this criterion with 0.7dB of margin. From Figure 2 one can see that the measured noise at maximum gain is about 190nV/ Rt, which is about 11dB above the 50nV/ Rt noise voltage at minimum gain.

To further illustrate the concept, a receive gain map for the MAX2082 is shown in **Figure 3**.

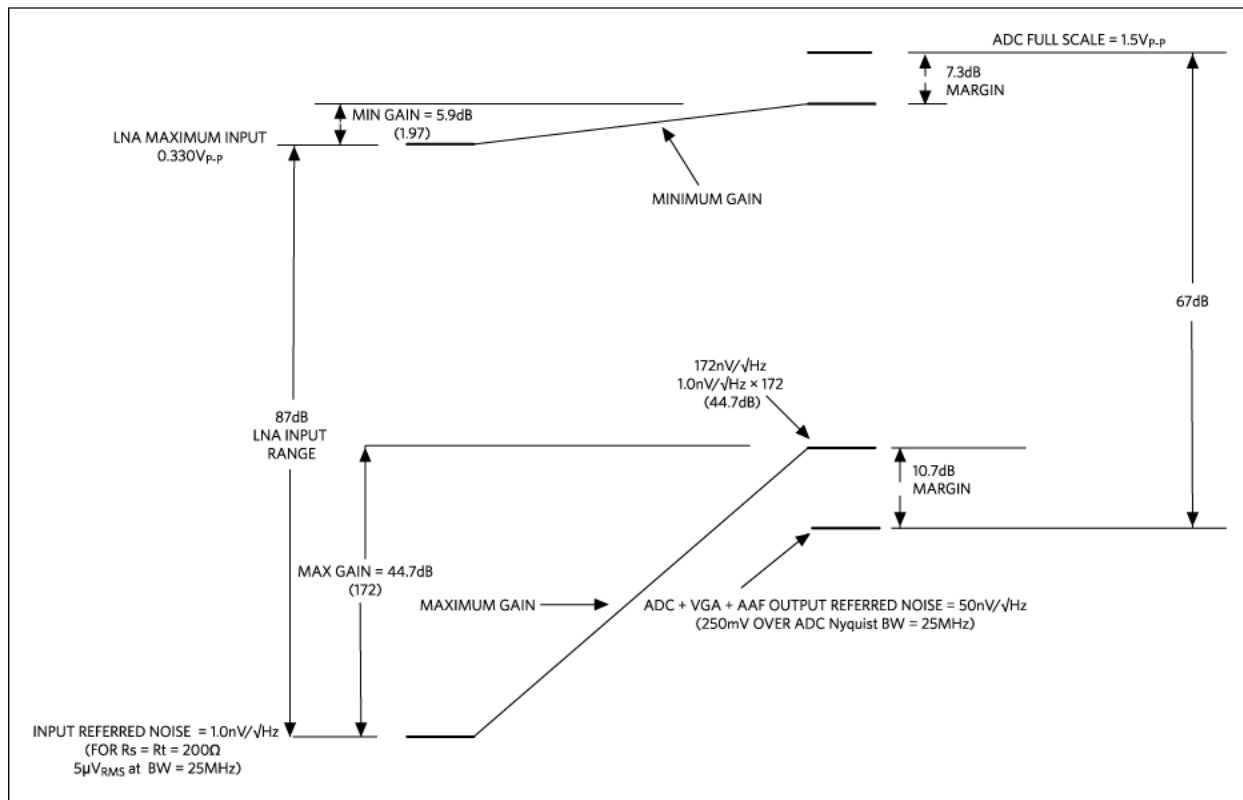

Figure 3. The MAX2082 gain map.

In this example it should be noted that we assumed an LNA gain of 18.5dB, as this is typically the most useful LNA gain setting. This gain setting provides sufficient LNA input range and very good noise figure. In most cases, higher LNA gain settings tend to reduce the LNA input range and restrict near-field imaging with marginal improvements in noise figure. For example, a 6dB increase in LNA gain typically lowers the input range by a factor of 2. Lower LNA gains, however, increase the allowable input range but sacrifice noise performance to an unacceptable level.

Negative Effects of Too Much Receiver Gain

For a typical receiver with a 12-bit ADC like the one integrated in the MAX2082 transceiver, increasing the maximum gain beyond 44.7dB is not necessary. A good noise figure is achieved at this gain level. Adding more gain will not increase receiver sensitivity or noise figure appreciably.

It should now be easy to see why lower-SNR receivers require more maximum gain. The ADCs in these receivers have a higher noise floor, assuming that the ADC maximum input range is about the same. Therefore, more receiver gain is necessary to maintain a good noise figure. Simply put, a receiver with 10dB less SNR needs approximately 10dB more maximum gain to provide the same noise-figure performance.

Users who migrate from a low-SNR receiver to a high-SNR receiver with reduced maximum gain can have

problems if the system is not optimized to accommodate these changes. We will address why this is true later in this application note. But now we need to consider why limiting the maximum gain of a 12-bit high-SNR receiver is needed at all. Certainly we have shown that we do not need as much maximum gain in a 12-bit high-SNR receiver as a 10-bit low-SNR receiver. The question remains: why not increase the maximum gain and gain range of the 12-bit receiver to match the 10-bit receiver and thus minimize any system problems when switching from a low- to high-SNR receiver? This is a very good question. The answer involves the practical design limitations of a VGA.

Increasing the maximum gain of a VGA inherently causes the output-referred noise of the VGA to increase as well. In a well-designed receiver the VGA output noise at low and medium gains should be well below the ADC noise. If this is the case, the receiver SNR at low and medium gains should be approximately the same as the ADC SNR—this is what we want. Unfortunately, if we try to increase the VGA maximum gain, the output noise of the VGA at medium and low gains begins to increase as well. When the VGA output noise approaches the level of the ADC noise, the SNR of the receiver begins to degrade.

This effect can easily be seen in some competitive ultrasound receivers with adjustable post-VGA gain amplifiers (PGAs) that allow users to increase the maximum VGA gain output. Close examination of the SNR versus gain plots for these devices show that the SNR degrades when the VGAs are operated in these high-PGA post-gain settings. Hence, these post-gain amplifiers offer limited benefit as they do little to improve noise figure and have a significant negative impact on receiver SNR.

System Design Issues

It is very important that the full ultrasound system be optimized to accommodate the increased SNR capabilities of new devices, including the digital beamformer (digital delay and summation), digital filters, detectors, and compression mapping. This is all shown in the simplified ultrasound receiver block diagram in **Figure 4**.

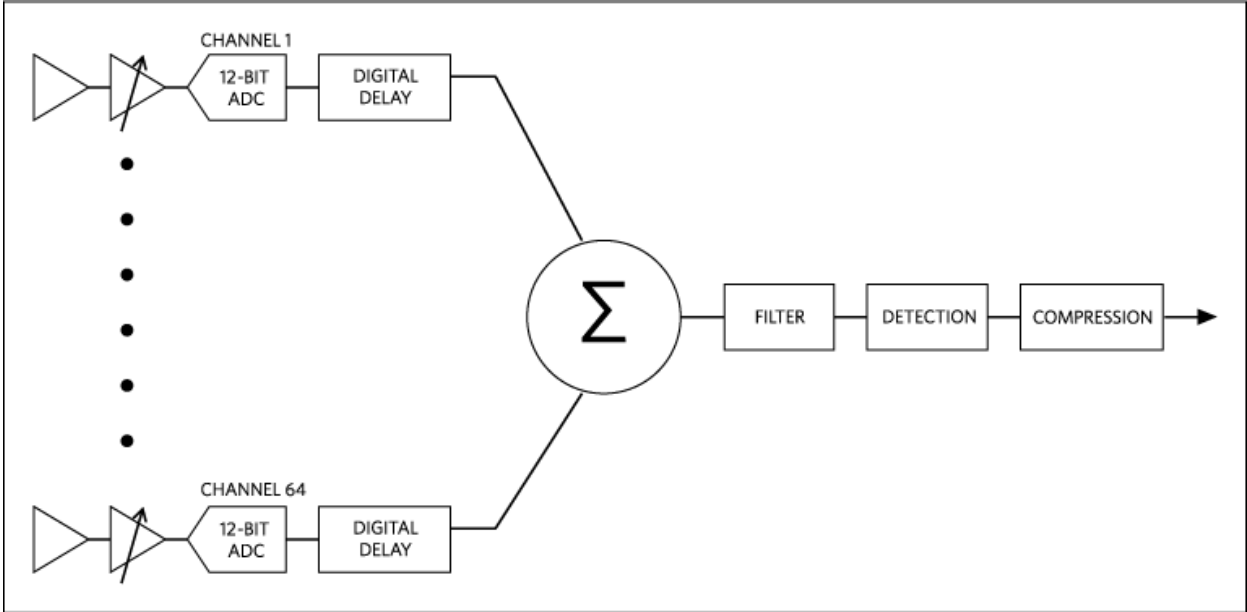

Figure 4. Simplified n-channel ultrasound-receiver beamformer block diagram.

If the digital beamformer, filters, detectors, and compression circuitry do not have sufficient dynamic range (i.e., enough bits) and/or if the compression mapping of the detected signal to display gray level is not properly set, then the SNR improvements of these new receivers cannot be realized. In addition, if these critical blocks have been optimized for older lower-SNR receivers, it will appear as if the new high-SNR receivers do not have sufficient maximum gain or adjustment range.

To illustrate the point consider a typical 64-channel system as shown in **Figure 5**.

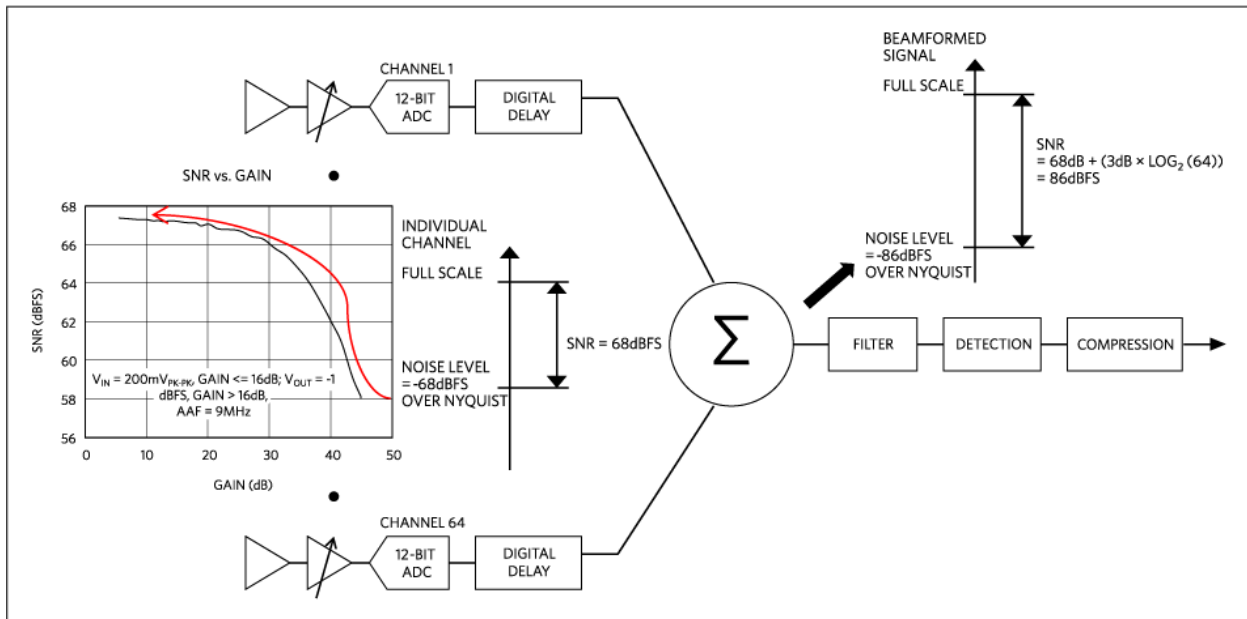

Figure 5. Simplified 64-channel ultrasound receiver system noise analysis at minimum VGA gain.

This example assumes the use of a MAX2082 transceiver. The SNR versus gain plot of a single receive channel is shown on the left in Figure 5. The plot shows that at low and medium gains the SNR is approximately 68dBFS. As expected, the SNR degrades as the gain increases; the amplified input noise of the receiver and transducer element becomes larger than the ADC noise. This can also be seen in the output noise versus gain plot of the MAX2082 shown in Figure 2.

The digital beamformer in this example delays and sums the digital outputs of the receivers to produce a digital beamformed output. When summing the outputs of the ADCs in the beamformer, the SNR increases by 3dB each time the number of channels is doubled. As a result, the SNR of the beamformed output for a 64-channel receiver will be about $68\text{dB} + (3\text{dB} \times \log_2(64)) = 86\text{dBFS}$ at low gains. The beamformer must maintain at least this dynamic range so its output should be at least 16 bits to sum the 12-bit outputs of all 64 channels. The output of the beamformer is typically filtered using a filter matched to the transducer bandwidth and then detected. These blocks must also maintain the necessary dynamic range. The output of the detector then needs to be mapped into the available limited display gray-scale dynamic range. A typical detector to gray-scale-mapping curve is shown in **Figure 6**.

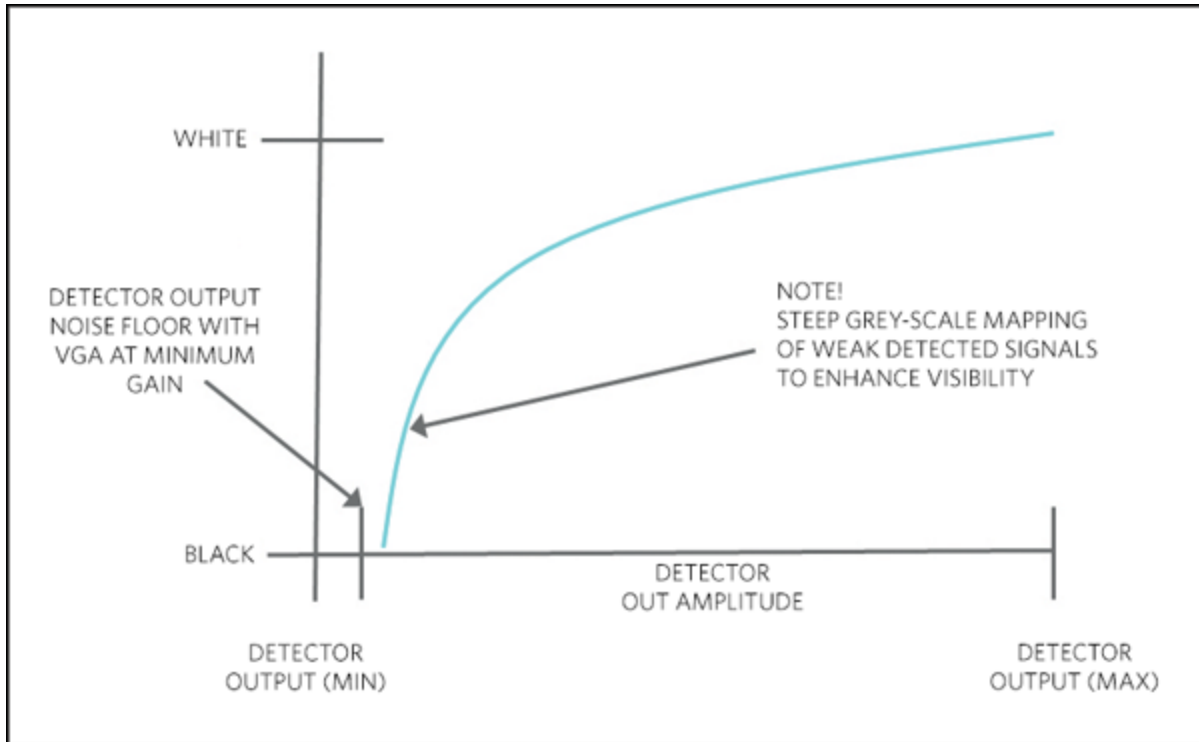

Figure 6. Detector output to gray-scale-mapping curve shows detector noise level with VGA at minimum gain.

There is a critical setting for proper system design: set the minimum gray display level or black level just above the detector output noise floor with the receivers at minimum gain. Setting the black level at this point ensures that the maximum dynamic range of the full receiver is maintained and that the output noise of the receivers at low and medium gains will not be visible in the image.

Now let us consider the case when the VGAs are at maximum gain, as shown in **Figure 7**. In this case, the single-channel SNR is about 59dBFS, as shown in the single-channel SNR versus gain plot in the figure. The 64-channel beamformer output SNR is, therefore, 77dBFS. Hence, the beamformer output noise at maximum VGA gain is about 11dB above the beamformer output noise with the VGAs at minimum gain.

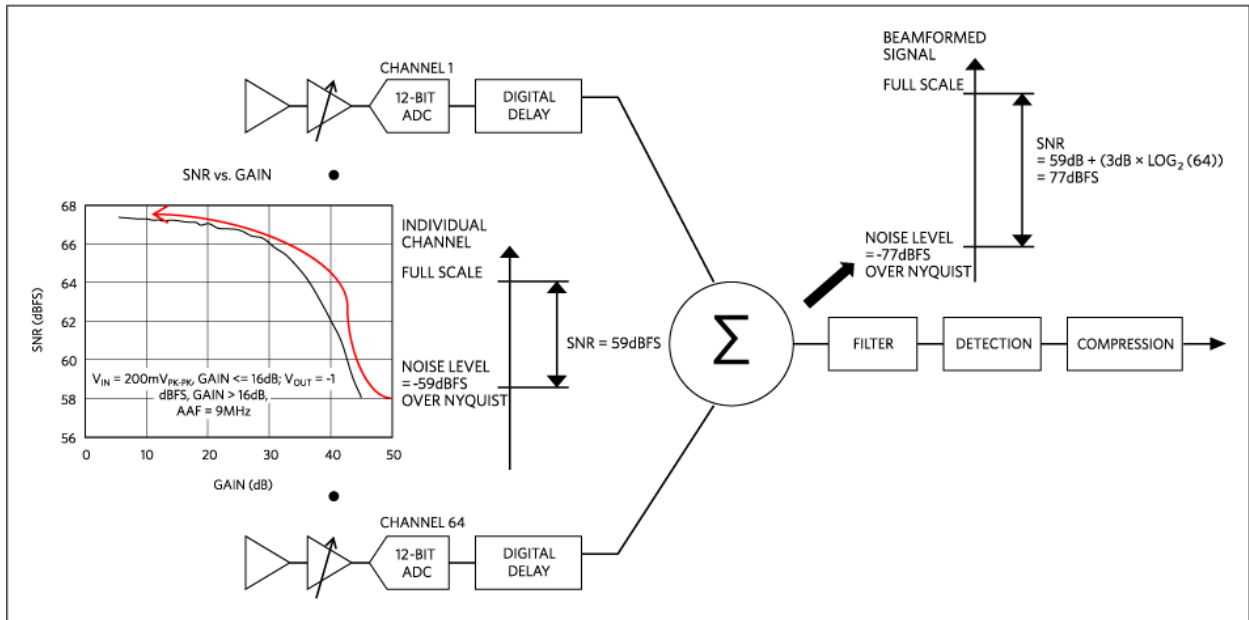

Figure 7. Simplified 64-channel ultrasound receiver system noise analysis at maximum VGA gain.

Under the maximum VGA gain conditions above in Figure 7 the detector noise floor should be as shown in **Figure 8** relative to the properly set compression curve. In this case, at high gains the low-level signals near the noise floor should be mapped to a clearly visible level in the B-mode display. It is important to note that the compression curve should be rather steep for low-level detected signals to make them clearly visible and to enhance the differential gray scale of these low-level signals.

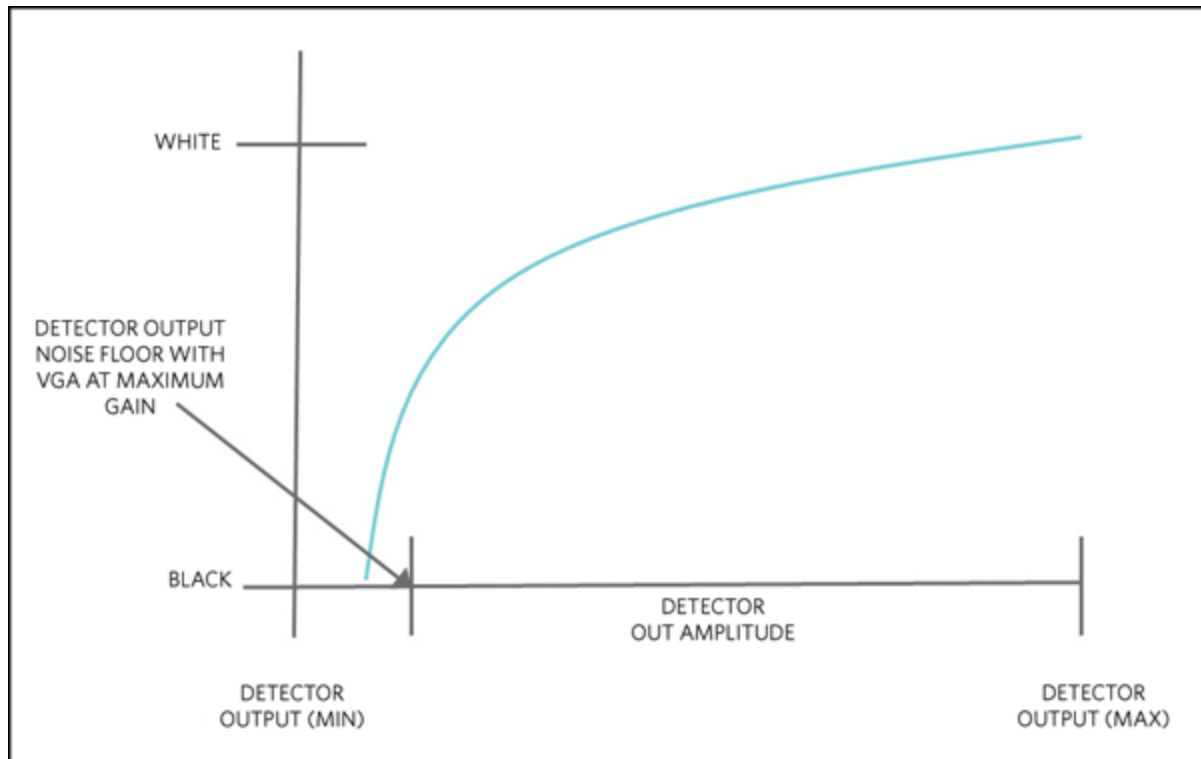

Figure 8. Detector output to gray-scale-mapping curve showing detector noise level with VGA at maximum gain.

It is easy to see from this analysis why one might believe that a higher maximum gain is necessary when using a high-SNR receiver, if the beamformer, filter, detector, and gray-scale mapping have been optimized for a lower-SNR 10-bit receiver. When using a low-SNR receiver the noise on the detector output at low VGA gains will be higher. Therefore, it is necessary to set the black level of the gray-scale-mapping curve higher to ensure that this noise will not be visible on the display. If, however, the receivers are now changed to high-SNR 12-bit receivers, the low-level signals at maximum VGA gain will fall below the black level of the compression curve. It will appear as if the receivers do not have sufficient gain.

There is another problem associated with the use of higher-SNR receivers and the necessary time gain-control (TGC) range of the system. In a typical ultrasound B-mode image, the time gain controls are adjusted so tissues of the same type have a uniform gray level from the near to far field in the image. To maintain a uniform gray scale, the necessary TGC gain adjustment range is in the order of 50dB. From our previous analysis, the required gain range for a high-SNR receiver like the one in the MAX2082 transceiver is only about 39dB. It is thus apparent that this analog gain adjustment range is not sufficient to provide the necessary TGC range.

Consequently, systems with high-SNR receivers must use digital gain adjustment techniques to provide additional TGC gain adjustment range. Typically, a digital attenuator under software control is placed after the beamformer to provide the necessary additional adjustment range. Below in **Figure 9** is a system block diagram with digital and analog gain maps. It shows how both the analog receiver VGA and digital gain

adjustments are used in combination to provide sufficient adjustment range. For lower TGC gains the adjustment is implemented digitally using a digital attenuator. In this example the lower 12dB of the adjustment range are implemented using this technique. For TGC gains beyond the lower 12dB of the TGC range, the gain adjustment is implemented using the analog VGAs in the receivers.

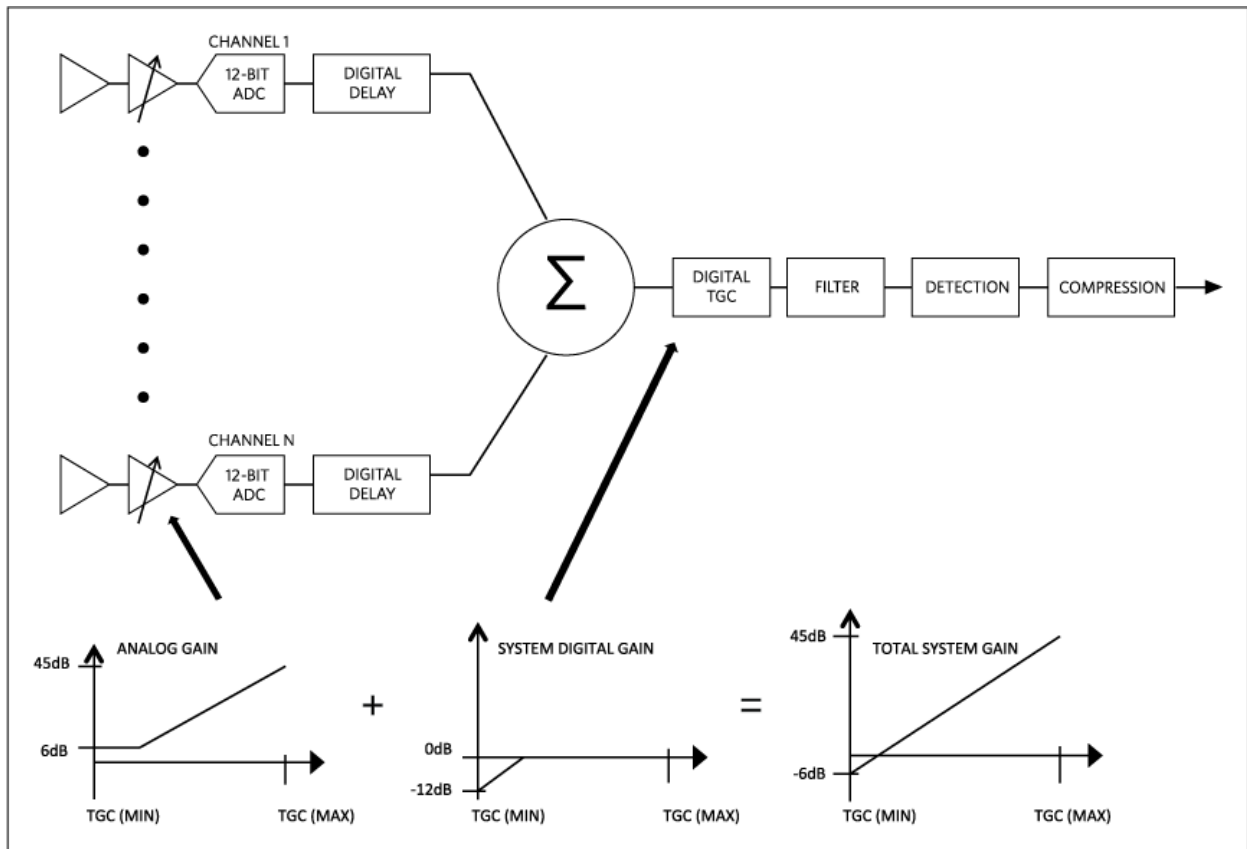

Figure 9. Combined analog receiver VGA and digital TGC gain adjust.

Conclusion

As newer ultrasound receivers become available with higher SNR, users need to ensure that their systems are properly designed to take advantage of these improvements.

Compensating for improper system design by selecting high PGA and LNA receiver-gain settings negates the positive SNR and LNA input range advantages of these more sophisticated receivers. Users must ensure that receiver dynamic range is maintained through the full digital beamforming, filtering, detection, and compression path and that the signals are appropriately mapped into the gray-level display range. Designers must also utilize a combination of digital and analog gain-adjustment techniques to implement the necessary TGC range as the SNR of new generation receivers continues to improve. Hopefully this application note has added clarity to these issues, making it easier for users to take advantage of the full performance offered by these new high-SNR receivers.

Related Parts		
MAX14808	Octal Three-Level/Quad Five-Level High-Voltage 2A Digital Pulsers with T/R Switch	Free Samples
MAX14809	Octal Three-Level/Quad Five-Level High-Voltage 2A Digital Pulsers with T/R Switch	Free Samples
MAX2079	Low-Power, High-Performance, Fully Integrated Octal Ultrasound Receiver (Octal LNA, VGA, AAF, ADC, and CWD Beamformer)	Free Samples
MAX2082	Low-Power, High-Performance Octal Ultrasound Transceiver with Integrated AFE, Pulser, T/R Switch, and CWD Beamformer	Free Samples

More Information

For Technical Support: <http://www.maximintegrated.com/en/support>

For Samples: <http://www.maximintegrated.com/en/samples>

Other Questions and Comments: <http://www.maximintegrated.com/en/contact>

Application Note 5765: <http://www.maximintegrated.com/en/an5765>

APPLICATION NOTE 5765, AN5765, AN 5765, APP5765, Appnote5765, Appnote 5765

© 2014 Maxim Integrated Products, Inc.

The content on this webpage is protected by copyright laws of the United States and of foreign countries.

For requests to copy this content, [contact us](#).

Additional Legal Notices: <http://www.maximintegrated.com/en/legal>