

NOTE

- 1.適合ターミナル : 56086シリーズ
APPLICABLE TERMINAL:56086 SERIES
- 2.適合リテーナー : 2014952100
APPLICABLE RETAINER:2014952100
- 3.嵌合相手 : 2014932100
MATE WITH:2014932100
- 4.ELV及びRoHS適合品
ELV AND RoHS COMPLIANT
- 5.材料/MATERIALS
ポリエステル (PBT) ,UL94V-0,ナチュラル (白)
POLYESTER(PBT),UL94V-0,NATURAL(WHITE)
- 6.製品仕様書 : 2014932100PS000
PRODUCT SPECIFICATION:2014932100PS000
- 7.本製品のプラスチック部に黒点等が確認される場合や色合いが異なる場合がありますが、製品性能に影響はありません
APPLICATION SPHERE IS NO INFLUENCE IN THE PRODUCT PREFORMANCE THOUGH THE BLACK SPOT ETC.
MIGHT BE CONFIRMED TO THE PLASTIC PART OF THE PRODUCT AND THE SHADE MIGHT BE DIFFERENT.

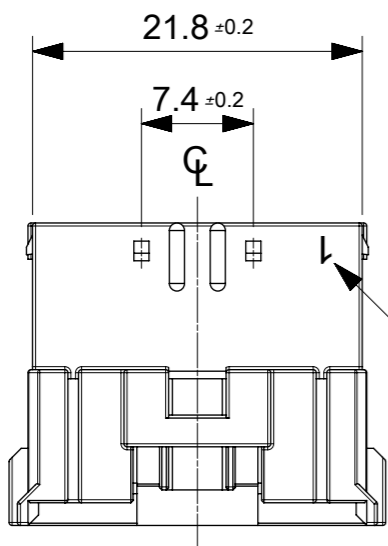

CIRCUIT NO.

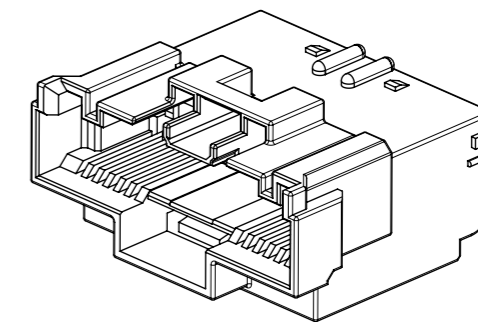
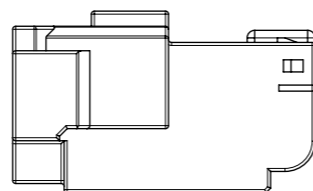
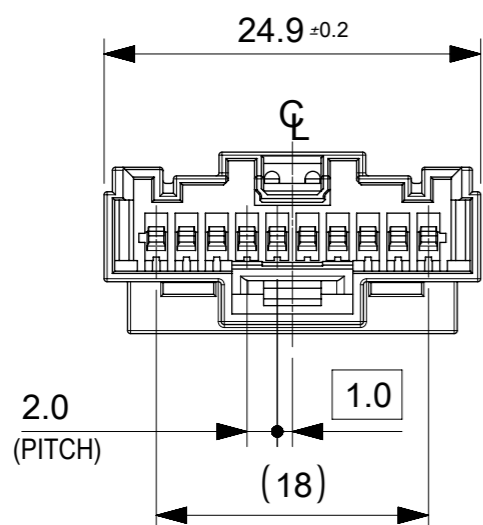

SERIES NO. : 201494

TRADE MARK : MXJ & CAV NO.

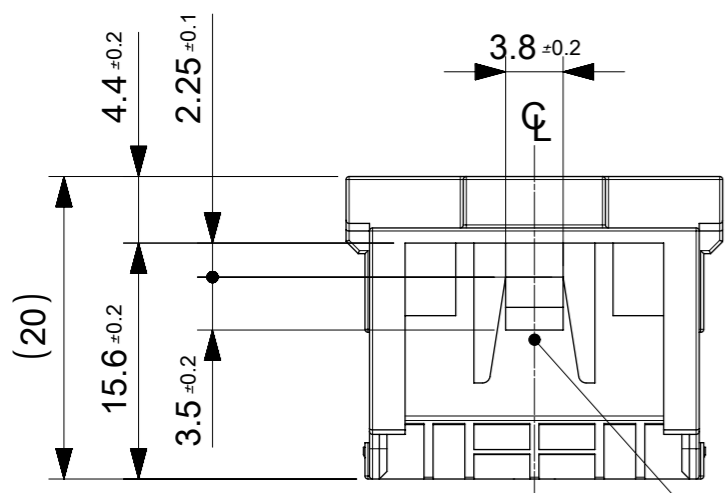
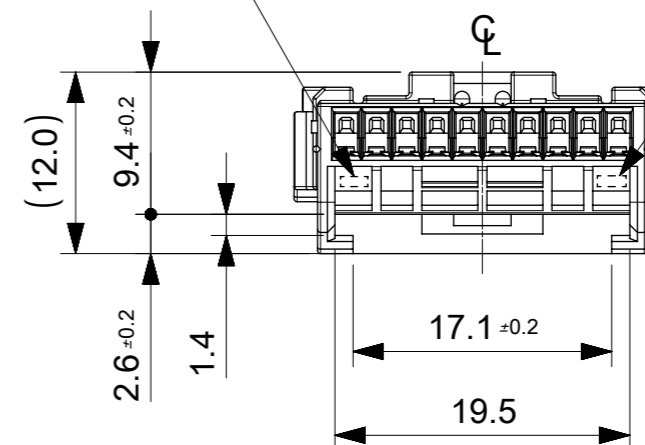

ブラケットロック面
LOCKING SURFACE ON CONNECTOR

2014942100
ORDER NO.

| | | | | | | | | |
|---------|---|---------------------------------------|------------------------|------------|--|-----------------|----------|--------------|
| SYMBOLS | THIS DRAWING CONTAINS INFORMATION THAT IS PROPRIETARY TO MOLEX ELECTRONIC TECHNOLOGIES, LLC AND SHOULD NOT BE USED WITHOUT WRITTEN PERMISSION | | CURRENT REV DESC: | | molex | | | |
| | ▽ = 0 | mm | SCALE | 2:1 | | | | |
| | ▽ = 0 | GENERAL TOLERANCES (UNLESS SPECIFIED) | | | | | | |
| | ▽ = 0 | ANGULAR TOL ± 3.0° | | | | | | |
| ▽ = 0 | 4 PLACES | ± 0.03 | EC NO: 618108 | 2019/05/29 | 2.0MM PITCH WIRE TO WIRE CONNECTOR PLUG HSG LOW-HALOGEN | | | |
| ▽ = 0 | 3 PLACES | ± 0.03 | DRWN: KNAGAI02 | 2019/06/03 | | | | |
| ▽ = 0 | 2 PLACES | ± 0.05 | CHK'D: SANDO | 2019/06/03 | PRODUCT CUSTOMER DRAWING | | | |
| ▽ = 0 | 1 PLACE | ± 0.1 | APPR: TOSADA | 2019/06/03 | | | | |
| □ = 0 | 0 PLACES | ± 0.2 | INITIAL REVISION: | | DOCUMENT NUMBER | DOC TYPE | DOC PART | REVISION |
| ■ = 0 | DRAFT WHERE APPLICABLE MUST REMAIN WITHIN DIMENSIONS | | THIRD ANGLE PROJECTION | DRAWING | SERIES | MATERIAL NUMBER | CUSTOMER | SHEET NUMBER |
| ▽ = 0 | | | | A3-SIZE | 201494 | 2014942100 | GENERAL | 1 OF 2 |

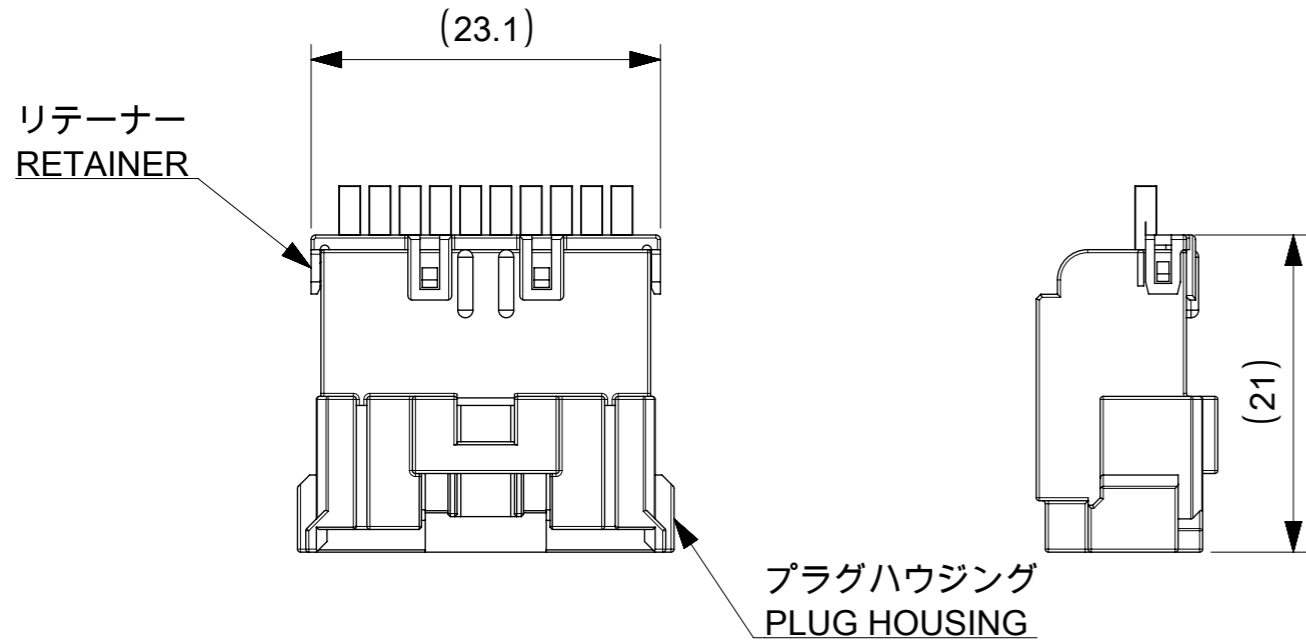

リテーナー装着図 / RETAINER ASSEMBLY DRAWING

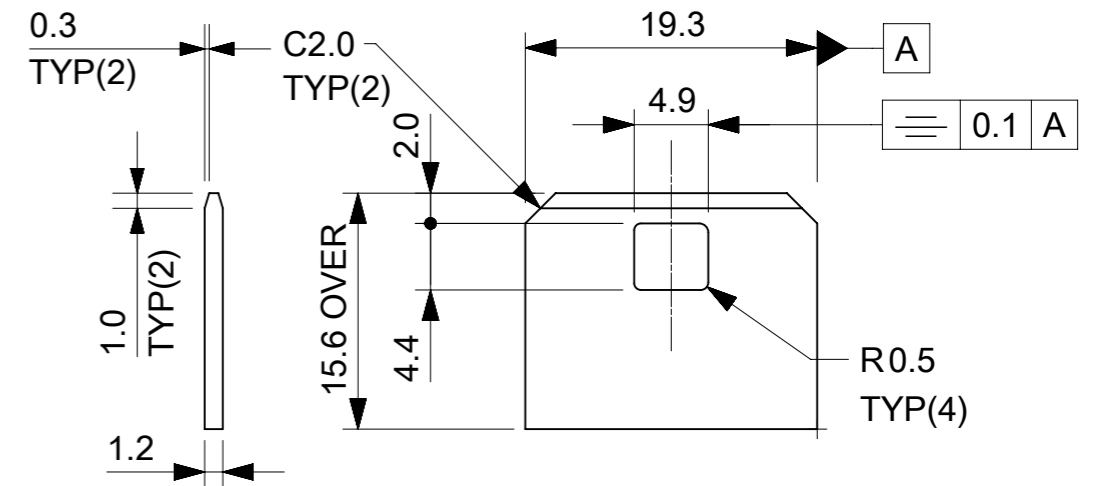

推奨ブラケット寸法 / RECOMMENDED BRACKET LAYOUT
 コネクタのブラケットロック面とブラケットダイ面で
 ロックする様設定ください。またダイ面にはバリ無き事。
 DIE SIDE OF BRACKET IS NEEDED TO LOCK
 WITH LOCKING SURFACE ON CONNECTOR.
 AND NO BURRS ON DIE SIDE OF BRACKET.

| SYMBOLS | | THIS DRAWING CONTAINS INFORMATION THAT IS PROPRIETARY TO MOLEX ELECTRONIC TECHNOLOGIES, LLC AND SHOULD NOT BE USED WITHOUT WRITTEN PERMISSION | |
|-----------------|--|---|--|
| DIMENSION UNITS | SCALE | CURRENT REV DESC: | |
| ▽ = 0 | mm | 2:1 | molex 2.0MM PITCH WIRE TO WIRE CONNECTOR PLUG HSG LOW-HALOGEN PRODUCT CUSTOMER DRAWING |
| ▽ = 0 | GENERAL TOLERANCES (UNLESS SPECIFIED) | | |
| ▽ = 0 | ANGULAR TOL ± 3.0° | | |
| ▽ = 0 | 4 PLACES | ± 0.03 | |
| ▽ = 0 | 3 PLACES | ± 0.03 | |
| ▽ = 0 | 2 PLACES | ± 0.05 | EC NO: 618108 DRWN: KNAGAI02 2019/05/29 CHK'D: SANDO 2019/06/03 APPR: TOSADA 2019/06/03 |
| ▽ = 0 | 1 PLACE | ± 0.1 | INITIAL REVISION: DRWN: TNAKATA 2016/04/08 APPR: YNOGAWA 2016/08/09 |
| ▽ = 0 | 0 PLACES | ± 0.2 | DOCUMENT NUMBER: 2014942100 DOC TYPE: PSD DOC PART: 000 REVISION: A2 |
| ■ = 0 | DRAFT WHERE APPLICABLE MUST REMAIN WITHIN DIMENSIONS | | THIRD ANGLE PROJECTION DRAWING: A3-SIZE SERIES: 201494 MATERIAL NUMBER: 2014942100 CUSTOMER: GENERAL SHEET NUMBER: 2 OF 2 |