

PART NUMBER	REVISION	DESCRIPTION	FEED TYPE
2151539-1	Y	FINE CRIMP HEIGHT ADJUST	MECHANICAL
2151539-2	Y	FINE CRIMP HEIGHT ADJUST	PNEUMATIC
3-2151539-2	Y	FINE CRIMP HEIGHT ADJUST	DOUBLE ACTING PNEUMATIC WITH SENSORS
7-2151539-1	Y	MECHANICAL AND CRIMP TOOLING KIT	MECHANICAL
7-2151539-2	Y	PNEUMATIC AND CRIMP TOOLING KIT	PNEUMATIC
7-2151539-7	Y	CRIMP TOOLING KIT	-

ATLANTIC VERSION TERMINATOR INTERFACE ADAPTER



APPLICATOR DATA		
CRIMP	SIZE	TYPE
WIRE	1.78 mm [.070]	F
INSUL	1.73 mm [.068]	SP

APPLICATOR INSTRUCTIONS 408-35042

TERMINAL DATA: TE TERMINAL		TE CRIMP SPECIFICATION	
TERMINAL NAME: GET 0.64mm PIN AND SOCKET CONTACTS			
WIRE STRIP LENGTH 4.40 mm [.173 IN]	INSULATION DIAMETER RANGE Ø1.40-2.06 mm [.055-.081 IN]		
TERMINAL APPLICATION SPECIFICATION	114-13060		
TERMINALS APPLIED			
TE TERMINAL	TE TERMINAL	TE TERMINAL	TE TERMINAL
1393366-1	1393365-1	1438299-3	1438299-4
1393366-2	1393365-2	1438299-6	1-1438299-1
2-1393366-2			

WIRE SIZE	CRIMP HEIGHT mm [INCH]	CRIMP HEIGHT REFERENCE SETTING
18 AWG	1.12 +/- 0.04 [.044 +/- .0016]	7.0
0.75mm ²	1.10 +/- 0.04 [.043 +/- .0016]	7.1
0.50mm ²	1.02 +/- 0.04 [.040 +/- .0016]	8.1
20 AWG	1.02 +/- 0.04 [.040 +/- .0016]	8.1

- 1 RECOMMENDED SPARE PARTS
- 2 REFER TO SUPPLIED INSTRUCTION SHEET FOR CLEANING, LUBRICATION AND STORAGE OF APPLICATOR.
- 3 APPLY PART NUMBER 2-23419-6 LOCTITE TO THREADS OF ITEM 242.
- 4 CRIMP HEIGHT REFERENCE SETTING WAS THE SETTING USED WHEN THE APPLICATOR WAS QUALIFIED AT THE FACTORY. ADJUSTMENT MAY BE NECESSARY WHEN RUNNING APPLICATOR IN THE FIELD.
- 5 REAR STRIP GUIDE MUST BE ADJUSTED WHEN SWITCHING TERMINALS.
- 6 USE ITEM 34, WHEN CRIMPING MALE TERMINALS.
- 7 USE ITEM 261, WHEN CRIMPING FEMALE TERMINALS.
- 8 TERMINAL LUBRICANT IS RECOMMENDED.
- 9. UNLESS SPECIFIED OTHERWISE TORQUE VALUES SHALL BE USED PER DOCUMENT, 101-35000.
- 10 THIS APPLICATOR IS EQUIPPED WITH THE DOUBLE ACTING FEED WITH SENSORS AND IS APPLICATION SPECIFIC. IT DOES NOT REQUIRE ITEM 49 & 248.

***WARNING**
ON INSTALLATION, SET WIRE DISC TO CRIMP HEIGHT REFERENCE SETTING FOR LARGEST WIRE SIZE. CRIMP HEIGHT REFERENCE SETTINGS GREATER THAN THE VALUE SHOWN MAY CAUSE DAMAGE TO THE CRIMP TOOLING, REFER TO THE INSTRUCTION SHEET FOR PROPER SETUP AND ADJUSTMENTS.

ATLANTIC VERSION
Shown on sheets 1 of 4 & 2 of 4
(Pacific version shown on sheets 3 of 4 & 4 of 4)

LOC		DIST		REVISIONS			
P	LTN	DESCRIPTION	DATE	OWN	APVD		
V		ECR-21-005185	08MAY2021	MZ	YY		
V1		ECR-21-006079	07JUN2021	LJ	YY		
W		ECR-21-118048	21OCT2021	FZ	RK		
Y		ECR-22-132999	18MAR2022	FJ	JAH		

-	1	1	1	1	1	22278-9	SPRING, COMPRESSION	300
-	2	2	2	2	2	4-18032-3	SCR, SET, FLT PNT, M3 X 6.0	299
-	1	1	1	1	1	3-1803945-1	TONKER	298
-	1	1	1	1	1	1803944-1	SPACER, TONKER	297
-	-	-	1	-	-	2844950-1	AIR FEED MODULE	290
7	1	1	1	1	1	3-1752356-3	SUPPORT, TERMINAL	261
10	-	1	-	-	-	2119641-1	FEED CAM, AIR FEED	248
-	1	1	1	1	1	2119082-7	CAM, SNAIL, INSULATION ADJUSTMENT	244
-	1	1	1	1	1	2079764-1	WASHER, WAVE SPRING, CREST-TO-CREST	243
3	-	1	1	1	1	2119083-1	RETAINER, INSULATION DIAL	242
-	1	1	1	1	1	7-18023-7	SCR, SKT HD CAP M3 X 4.0	241
-	-	1	-	-	-	2119580-1	MECHANICAL FEED ASSEMBLY	239
-	1	-	-	-	-	2844940-1	AIR FEED MODULE	238
-	REF	REF	REF	REF	REF	994970-2	COUNTER, MAGNETIC	164
-	1	1	1	1	1	1-22281-8	SPRING, COMPRESSION	121
8	-	1	1	1	1	2119955-1	ASSY, LUBRICATOR, SIDE FEED	113
-	1	1	1	1	1	2844908-1	SCREW, LOCKING	99
-	1	1	1	1	1	2844907-1	POST, LOCKING	98
-	1	1	1	1	1	2-690438-2	FRONT STRIP GUIDE	96
-	2	2	2	2	2	2168083-1	SCR, SKT HD CAP, RoHS, M3 X 8.0	95
-	1	1	1	1	1	2168083-6	SCR, SKT HD CAP, RoHS, M5 X 65	93
-	1	1	1	1	1	455888-8	SPACER, CRIMPER	82
-	1	1	1	1	1	1803607-3	DOCUMENTATION PACKAGE	71
-	1	1	1	1	1	2119791-5	DEPRESSOR, WIRE	70
-	1	1	1	1	1	2119740-1	TAG, IDENTIFICATION	67
-	2	2	2	2	2	2168078-1	SCREW, DRIVE, RH, RoHS, 2 x .188	66
-	2	2	2	2	2	2-18032-5	SCR, SET, FLT PNT, M5 X 20.0	61
-	1	1	1	1	1	2168083-2	SCR, SKT HD CAP, RoHS, M4 X 8.0	60
-	1	1	1	1	1	5-18022-5	SCR, HEX HD CAP, M4 X 6.0	59
-	1	1	1	1	1	1338685-1	PAWL, FEED	56
-	4	4	4	4	4	2168083-3	SCR, SKT HD CAP, RoHS, M4 X 12.0	54
-	2	2	2	2	2	2168083-3	SCR, SKT HD CAP, RoHS, M4 X 12.0	53
10	-	1	2	-	1	18023-9	SCR, SKT HD CAP M4 X 6.0	49
-	-	1	-	-	-	2119652-1	FEED CAM, PRE FEED	48
-	-	1	-	-	-	2119653-1	FEED CAM, POST FEED	47
-	1	1	1	1	1	1803583-9	APPLICATOR BASIC ASSEMBLY, SF	46
-	1	1	1	1	1	1803515-1	RAM ASSEMBLY, SF ATLANTIC	44
-	1	1	1	1	1	1803602-1	SCR, BHSC, RoHS (M8 X 25)	41
6	-	1	1	1	1	1752356-1	SUPPORT, TERMINAL	34
-	2	2	2	2	2	2079383-5	SCR, BHSC, RoHS (M4 X 20)	33
-	2	2	2	2	2	2-2844962-4	SPACER, CYLINDRICAL, STRIP GUIDE	30
-	1	1	1	1	1	2844938-5	PLATE, STRIP GUIDE	29
-	2	2	2	2	2	22281-8	SPRING, COMPRESSION	27
-	1	1	1	1	1	356835-1	LEVER, DRAG RELEASE	26
-	1	1	1	1	1	217233-1	DRAG, STOCK	25
-	1	1	1	1	1	1320928-6	STRIP GUIDE	24
-	1	1	1	1	1	980371-4	SCR, SKT HD SHLDR 5.0 DIA X 6.0	23
-	1	1	1	1	1	2168083-2	SCR, SKT HD CAP, RoHS, M4 X 8.0	21
-	2	2	2	2	2	1-18028-2	WASHER, FLAT, REG M4	20
-	1	1	1	1	1	2119533-1	STRIPPER, SIDE FEED	19
1	-	1	1	1	1	2119806-1	INSERT, SHEAR	13
-	1	1	1	1	1	3-22280-3	SPRING, COMPRESSION	12
-	1	1	1	1	1	1-356885-4	STOP, SHEAR	11
1	-	1	1	1	1	2119805-1	SHEAR HOLDER, FRONT	10
1	-	1	1	1	1	318707-1	FLOATING SHEAR, FRONT	9
1	1	2	2	1	1	6-1803763-7	COMBINATION, ANVIL	8
-	-	-	-	-	-	-	-	7
-	-	-	-	-	-	-	-	6
-	1	1	1	1	1	2119757-8	DEPRESSOR, SHEAR	5
-	1	1	1	1	1	3-238011-5	BLOCK, CRIMPER SPACER	4
1	1	2	2	1	1	2-1633989-1	CRIMPER, INSULATION, SPECIAL	3
-	1	1	1	1	1	455888-1	SPACER, CRIMPER	2
1	1	2	2	1	1	5-562108-2	CRIMPER, WIRE, F	1

DIMENSIONS:		TOLERANCES UNLESS OTHERWISE SPECIFIED:		APPLICATOR DATA		DESCRIPTION		ITEM NO
mm	0 PLC ±	1 PLC ±	2 PLC ±	3 PLC ±	4 PLC ±	APVD	DESCRIPTION	
	ANGLES	FINISH				WEIGHT	DESCRIPTION	
MATERIAL						SCALE	DESCRIPTION	

Customer Accessible Production Drawing

LOC	DIST	REVISIONS					
A	66	P	LYN	DESCRIPTION	DATE	DWN	APVD
		-		SEE SHEET 1			

FEED TYPE MECHANICAL

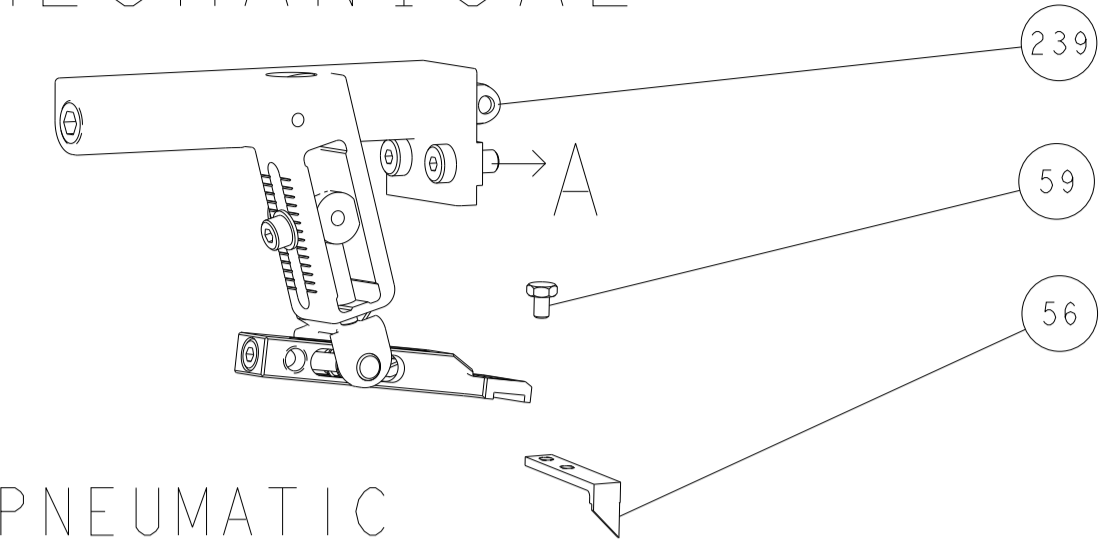

PNEUMATIC

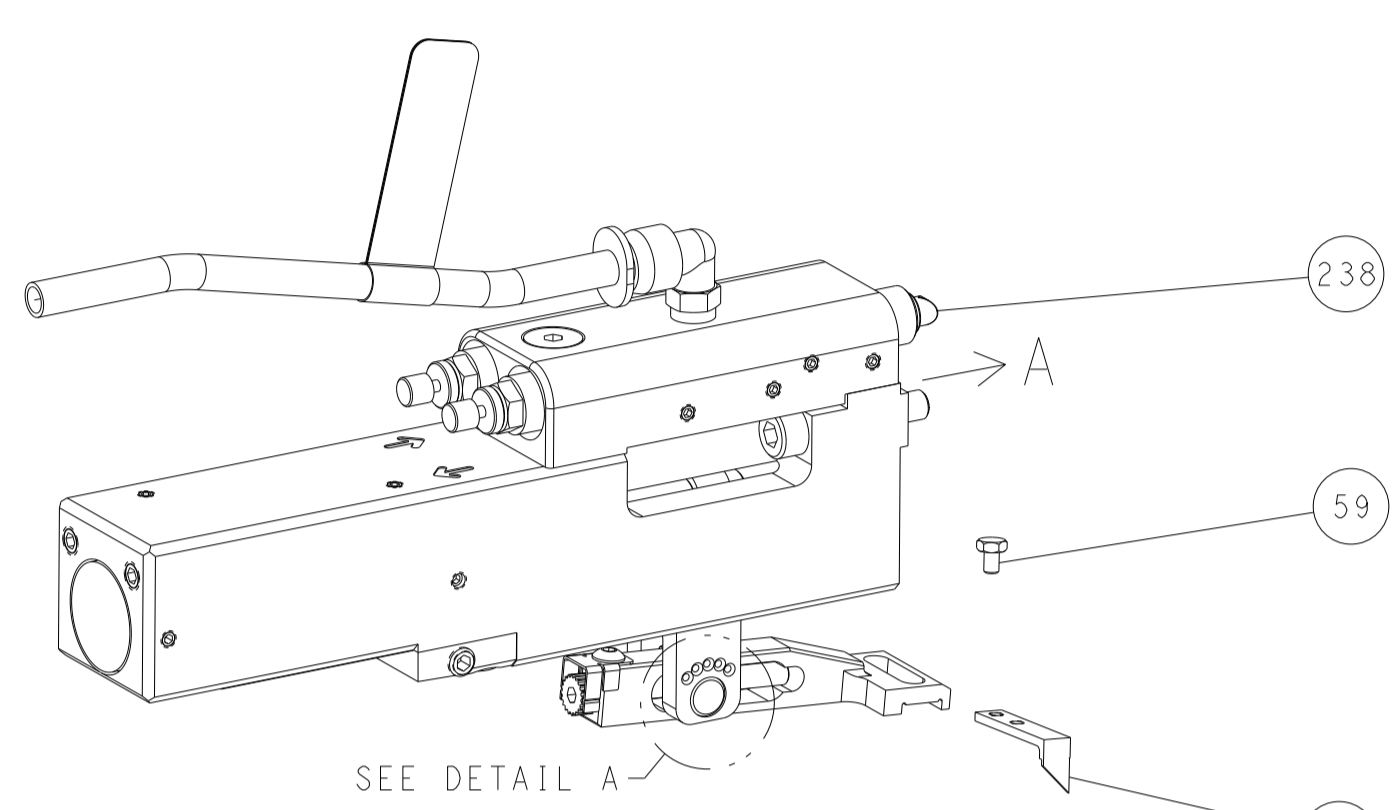

SEE DETAIL A
 FEED SPRING SETTING POSITION
 (SHOWN FROM REAR SIDE)

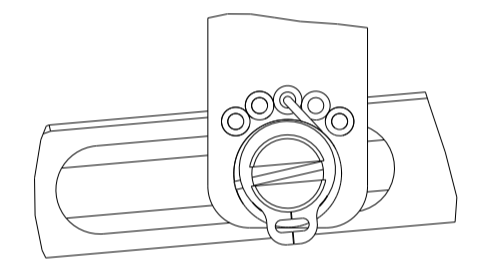

DETAIL A

DOUBLE ACTING PNEUMATIC WITH SENSORS

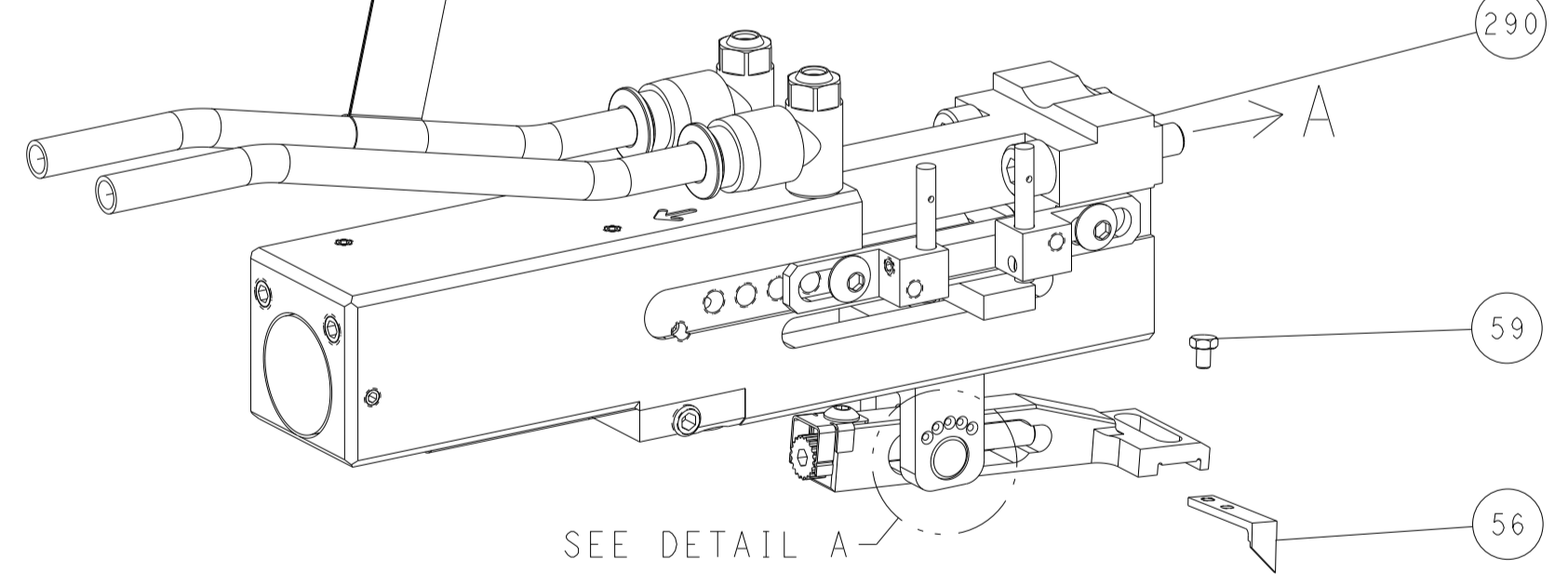

SEE DETAIL A

CAM POSITIONS

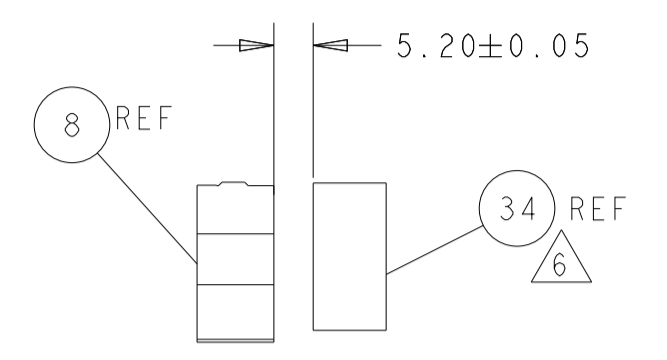
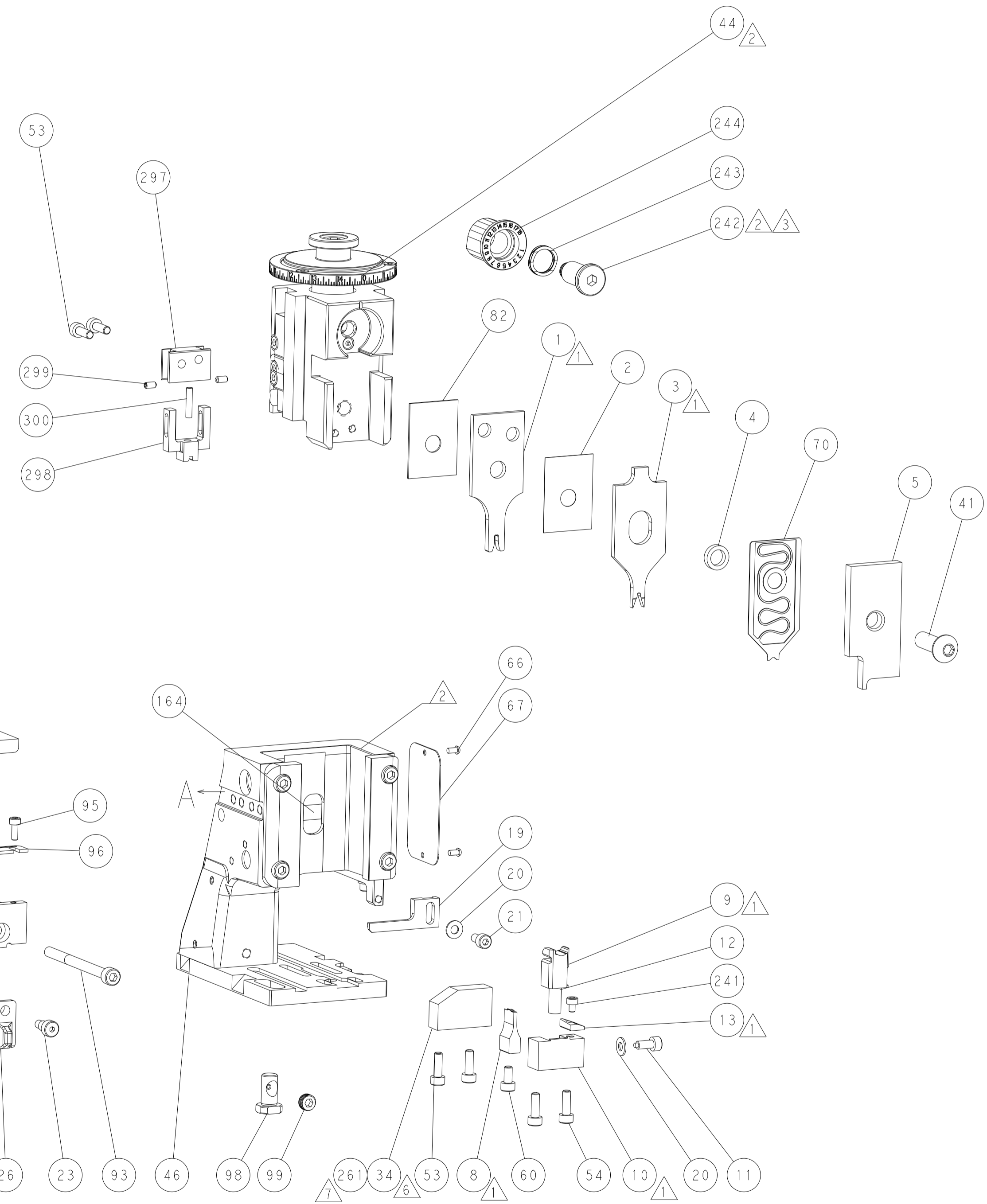
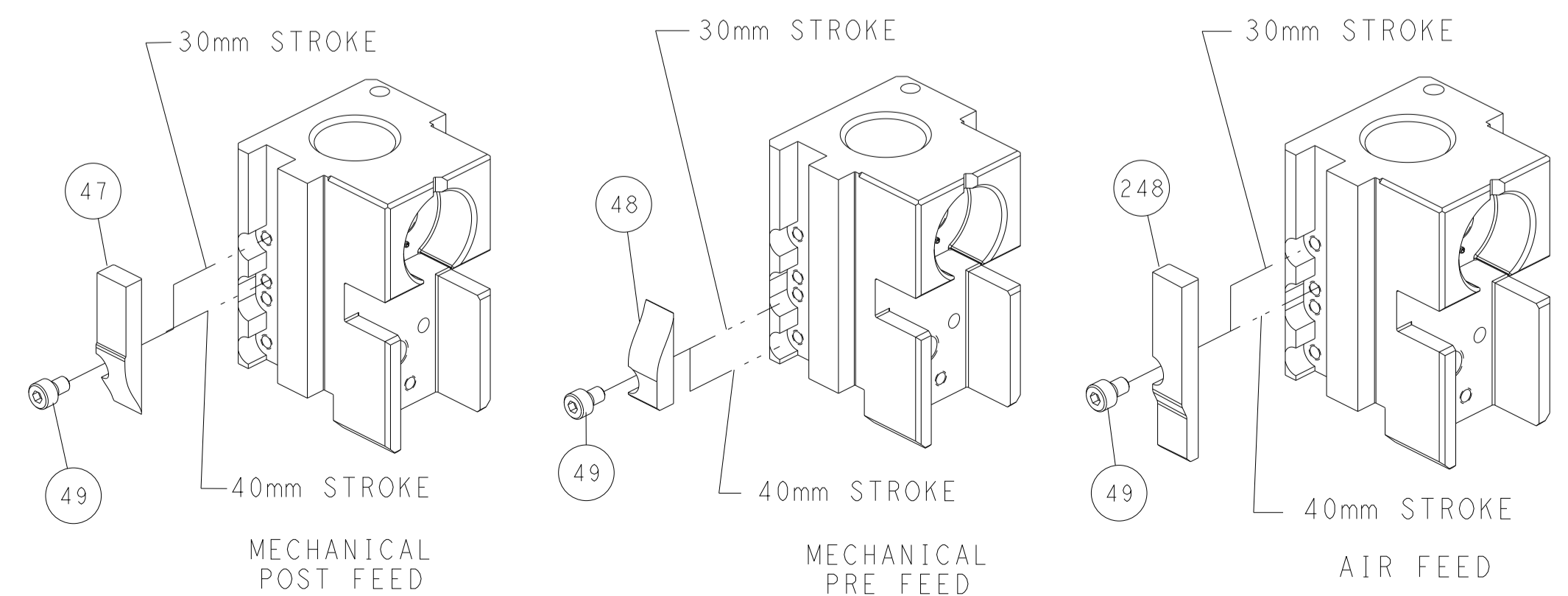

TERMINAL SUPPORT LOCATION
FOR MALE TERMINAL

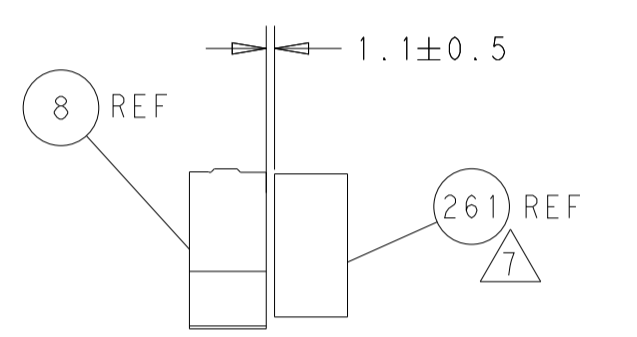

TERMINAL SUPPORT LOCATION
FOR FEMALE TERMINAL

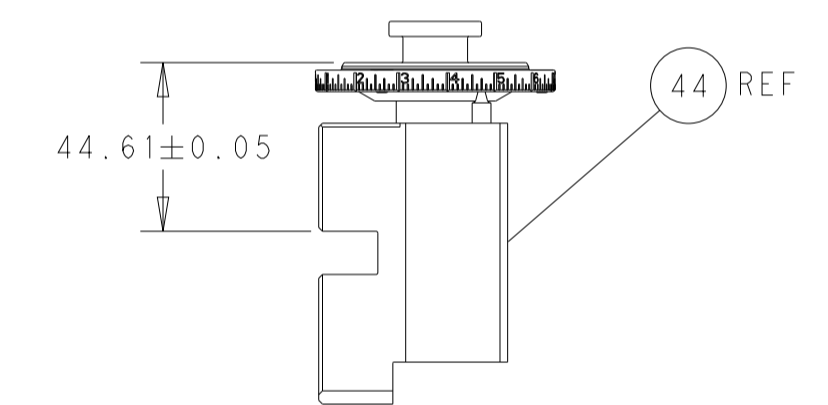

RAM SET-UP

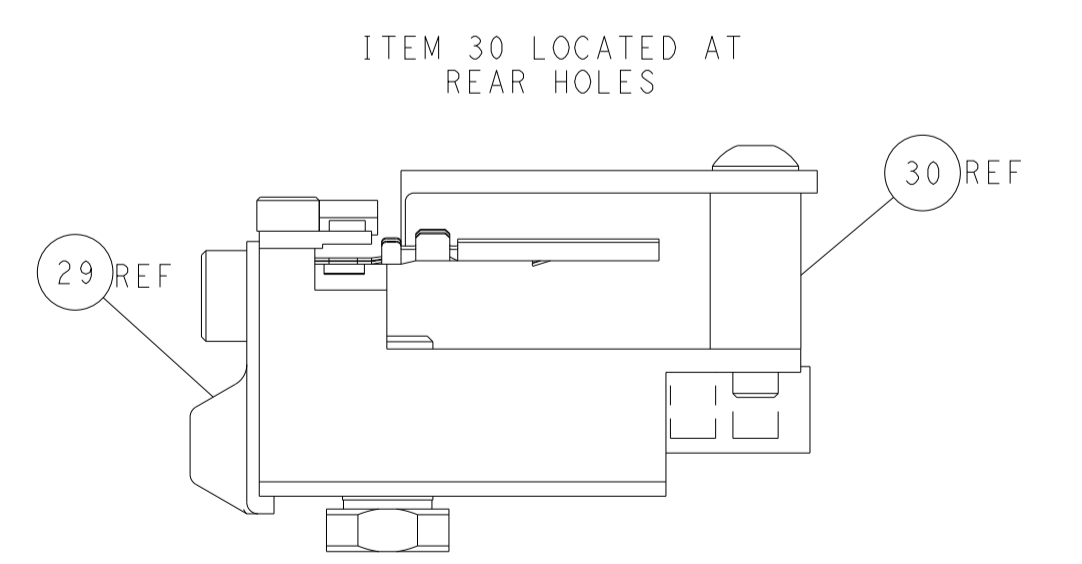

ITEM 30 LOCATED AT
REAR HOLES

FEED TRACK POSITION
GUIDE BY INSULATION BARREL

ATLANTIC VERSION
 Shown on sheets 1 of 4 & 2 of 4
 (Pacific version shown on sheets 3 of 4 & 4 of 4)

DIMENSIONS: mm		TOLERANCES UNLESS OTHERWISE SPECIFIED: 0 PLC ± 1 PLC ± 2 PLC ± 3 PLC ± 4 PLC ± ANGLES ± FINISH		DWN C. MOYER Z0DEC2012 CHK T. ELBIN Z0DEC2012 APVD T. ELBIN Z0DEC2012 PRODUCT SPEC APPLICATION SPEC WEIGHT Customer Accessible Production Drawing		NAME Ocean Side Feed Applicator SIZE CAGE CODE DRAWING NO A1 00779 C=2151539 SCALE 1:2 SHEET 2 OF 4 REV Y		RESTRICTED TO	
SHEETS 3 & 4 ARE NOT REQUIRED FOR ATLANTIC VERSION									

PART NUMBER	REVISION	DESCRIPTION	FEED TYPE
2-2151539-1	Y	FINE CRIMP HEIGHT ADJUST	MECHANICAL
2-2151539-2	Y	FINE CRIMP HEIGHT ADJUST	PNEUMATIC
4-2151539-2	Y	FINE CRIMP HEIGHT ADJUST	DOUBLE ACTING PNEUMATIC WITH SENSORS
7-2151539-7	Y	CRIMP TOOLING KIT	-

PACIFIC VERSION TERMINATOR INTERFACE ADAPTER



APPLICATOR DATA		
CRIMP	SIZE	TYPE
WIRE	1.78 mm [.070]	F
INSUL	1.73 mm [.068]	SP
APPLICATOR INSTRUCTIONS 408-35042		

TERMINAL DATA: TE TERMINAL TE CRIMP SPECIFICATION			
TERMINAL NAME: GET 0.64mm PIN AND SOCKET CONTACTS			
WIRE STRIP LENGTH	INSULATION DIAMETER RANGE		
4.40 mm [.173 IN]	Ø1.40-2.06 mm [.055-.081 IN]		
TERMINAL APPLICATION SPECIFICATION	114-13060		
TERMINALS APPLIED			
TE TERMINAL	TE TERMINAL	TE TERMINAL	TE TERMINAL
1393366-1	1393365-1	1438299-3	1438299-4
1393366-2	1393365-2	1438299-6	1-1438299-1
2-1393366-2			

WIRE SIZE	CRIMP HEIGHT mm [INCH]	CRIMP HEIGHT REFERENCE SETTING
18 AWG	1.12 +/- 0.04 [.044 +/- .0016]	7.0
0.75mm2	1.10 +/- 0.04 [.043 +/- .0016]	7.1
0.50mm2	1.02 +/- 0.04 [.040 +/- .0016]	8.1
20 AWG	1.02 +/- 0.04 [.040 +/- .0016]	8.1

- RECOMMENDED SPARE PARTS
- REFER TO SUPPLIED INSTRUCTION SHEET FOR CLEANING, LUBRICATION AND STORAGE OF APPLICATOR.
- APPLY PART NUMBER 2-23419-6 LOCTITE TO THREADS OF ITEM 242.
- CRIMP HEIGHT REFERENCE SETTING WAS THE SETTING USED WHEN THE APPLICATOR WAS QUALIFIED AT THE FACTORY. ADJUSTMENT MAY BE NECESSARY WHEN RUNNING APPLICATOR IN THE FIELD.
- REAR STRIP GUIDE MUST BE ADJUSTED WHEN SWITCHING TERMINALS.
- USE ITEM 34, WHEN CRIMPING MALE TERMINALS.
- USE ITEM 261, WHEN CRIMPING FEMALE TERMINALS.
- TERMINAL LUBRICANT IS RECOMMENDED.
- 9. UNLESS SPECIFIED OTHERWISE TORQUE VALUES SHALL BE USED PER DOCUMENT, 101-35000.
- THIS APPLICATOR IS EQUIPPED WITH THE DOUBLE ACTING FEED WITH SENSORS AND IS APPLICATION SPECIFIC. IT DOES NOT REQUIRE ITEM 49 & 151.

ENTRY LEVEL APPLICATOR		ITEM SUBSTITUTION LIST		
PART NUMBER	SAME AS	ITEM	ITEM DESCRIPTION	SUBSTITUTE PART NUMBER
8-2151539-1	2151539-1	1	WIRE CRIMPER	5-1803529-2
8-2151539-2	2151539-2	3	INSULATION CRIMPER	2-1803623-1
9-2151539-1	2-2151539-1	46	BASIC SUB -ASSEMBLY	1803940-9
9-2151539-2	2-2151539-2	141	BASIC SUB -ASSEMBLY	1-1803940-0
			LUBRICATOR	DELETE

***WARNING**
ON INSTALLATION, SET WIRE DISC TO CRIMP HEIGHT REFERENCE SETTING FOR LARGEST WIRE SIZE. CRIMP HEIGHT REFERENCE SETTINGS GREATER THAN THE VALUE SHOWN MAY CAUSE DAMAGE TO THE CRIMP TOOLING, REFER TO THE INSTRUCTION SHEET FOR PROPER SETUP AND ADJUSTMENTS.

PACIFIC VERSION
Shown on sheets 3 of 4 & 4 of 4
(Atlantic version shown on sheets 1 of 4 & 2 of 4)

LOC	DIST	REVISIONS					
A	66	P	LTN	DESCRIPTION	DATE	OWN	APVD
-	-	-	-	SEE SHEET 1	-	-	-

-	1	1	1	22278-9	SPRING, COMPRESSION	300
-	2	2	2	4-18032-3	SCR, SET, FLT PNT, M3 X 6.0	299
-	1	1	1	3-1803945-1	TONKER	298
-	1	1	1	1803944-1	SPACER, TONKER	297
-	1	-	-	2844950-1	AIR FEED MODULE	290
-	1	1	1	3-1752356-3	SUPPORT, TERMINAL	261
-	1	1	1	2119082-7	CAM, SNAIL, INSULATION ADJUSTMENT	244
-	1	1	1	2079764-1	WASHER, WAVE SPRING, CREST-TO-CREST	243
-	1	1	1	2119083-1	RETAINER, INSULATION DIAL	242
-	1	1	1	7-18023-7	SCR, SKT HD CAP M3 X 4.0	241
-	-	-	1	2119580-1	MECHANICAL FEED ASSEMBLY	239
-	-	1	-	2844940-1	AIR FEED MODULE	238
-	REF	REF	REF	994970-2	COUNTER, MAGNETIC	164
-	-	1	-	2119641-2	FEED CAM, AIR FEED	151
-	1	1	1	2168083-8	SCR, SKT HD CAP, RoHS, M4 X 16	144
-	4	4	4	2168083-9	SCR, SKT HD CAP, RoHS, M4 X 20	143
-	-	-	1	2119653-2	FEED CAM, POST FEED	142
-	1	1	1	1-1803583-0	APPLICATOR BASIC ASSEMBLY, SF	141
-	1	1	1	1803516-1	RAM ASSEMBLY, SF PACIFIC	140
-	1	1	1	1-22281-8	SPRING, COMPRESSION	121
-	1	1	1	2119955-1	ASSY, LUBRICATOR, SIDE FEED	113
-	1	1	1	2844908-1	SCREW, LOCKING	99
-	1	1	1	2844907-1	POST, LOCKING	98
-	1	1	1	2-690438-2	FRONT STRIP GUIDE	96
-	2	2	2	2168083-1	SCR, SKT HD CAP, RoHS, M3 X 8.0	95
-	1	1	1	2168083-6	SCR, SKT HD CAP, RoHS, M5 X 65	93
-	1	1	1	455888-8	SPACER, CRIMPER	82
-	1	1	1	1803607-3	DOCUMENTATION PACKAGE	71
-	1	1	1	2119791-5	DEPRESSOR, WIRE	70
-	1	1	1	2119740-1	TAG, IDENTIFICATION	67
-	2	2	2	2168078-1	SCREW, DRIVE, RH, RoHS, 2 x .188	66
-	2	2	2	2-18032-5	SCR, SET, FLT PNT, M5 X 20.0	61
-	1	1	1	5-18022-5	SCR, HEX HD CAP, M4 X 6.0	59
-	1	1	1	1338685-1	PAWL, FEED	56
-	2	2	2	2168083-3	SCR, SKT HD CAP, RoHS, M4 X 12.0	53
-	-	1	2	18023-9	SCR, SKT HD CAP M4 X 6.0	49
-	-	-	1	2119652-1	FEED CAM, PRE FEED	48
-	1	1	1	1803602-1	SCR, BHSC, RoHS (M8 X 25)	41
-	1	1	1	1752356-1	SUPPORT, TERMINAL	34
-	2	2	2	2079383-5	SCR, BHSC, RoHS (M4 X 20)	33
-	2	2	2	2-2844962-4	SPACER, CYLINDRICAL, STRIP GUIDE	30
-	1	1	1	2844938-5	PLATE, STRIP GUIDE	29
-	2	2	2	22281-8	SPRING, COMPRESSION	27
-	1	1	1	356835-1	LEVER, DRAG RELEASE	26
-	1	1	1	217233-1	DRAG, STOCK	25
-	1	1	1	1320928-6	STRIP GUIDE	24
-	1	1	1	980371-4	SCR, SKT HD SHLDR 5.0 DIA X 6.0	23
-	1	1	1	2168083-2	SCR, SKT HD CAP, RoHS, M4 X 8.0	21
-	2	2	2	1-18028-2	WASHER, FLAT, REG M4	20
-	1	1	1	2119533-1	STRIPPER, SIDE FEED	19
-	1	1	1	2119806-1	INSERT, SHEAR	13
-	1	1	1	3-22280-3	SPRING, COMPRESSION	12
-	1	1	1	1-356885-4	STOP, SHEAR	11
-	1	1	1	2119805-1	SHEAR HOLDER, FRONT	10
-	1	1	1	318707-1	FLOATING SHEAR, FRONT	9
-	1	1	1	6-1803763-7	COMBINATION, ANVIL	8
-	-	-	-	-	-	7
-	-	-	-	-	-	6
-	1	1	1	2119757-8	DEPRESSOR, SHEAR	5
-	1	1	1	3-238011-5	BLOCK, CRIMPER SPACER	4
-	1	1	1	2-1633989-1	CRIMPER, INSULATION, SPECIAL	3
-	1	1	1	455888-1	SPACER, CRIMPER	2
-	1	1	1	5-562108-2	CRIMPER, WIRE, F	1

DIMENSIONS:		TOLERANCES UNLESS OTHERWISE SPECIFIED:		MATERIAL:		FINISH:		WEIGHT:		SCALE:		SHEET:		REV:									
0 PLC	±	1 PLC	±	2 PLC	±	3 PLC	±	4 PLC	±	ANGLES	±	FINISH	±	WEIGHT	±	SCALE	1:2	SHEET	3	OF	4	REV	Y

LOC	DIST	REVISONS	DATE	DWN	APVD
A	66	SEE SHEET 1			

FEED TYPE MECHANICAL

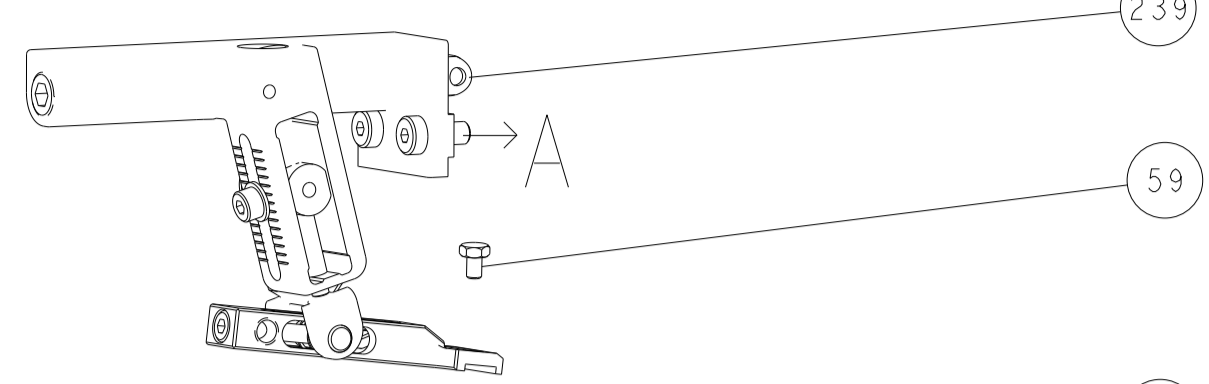

PNEUMATIC

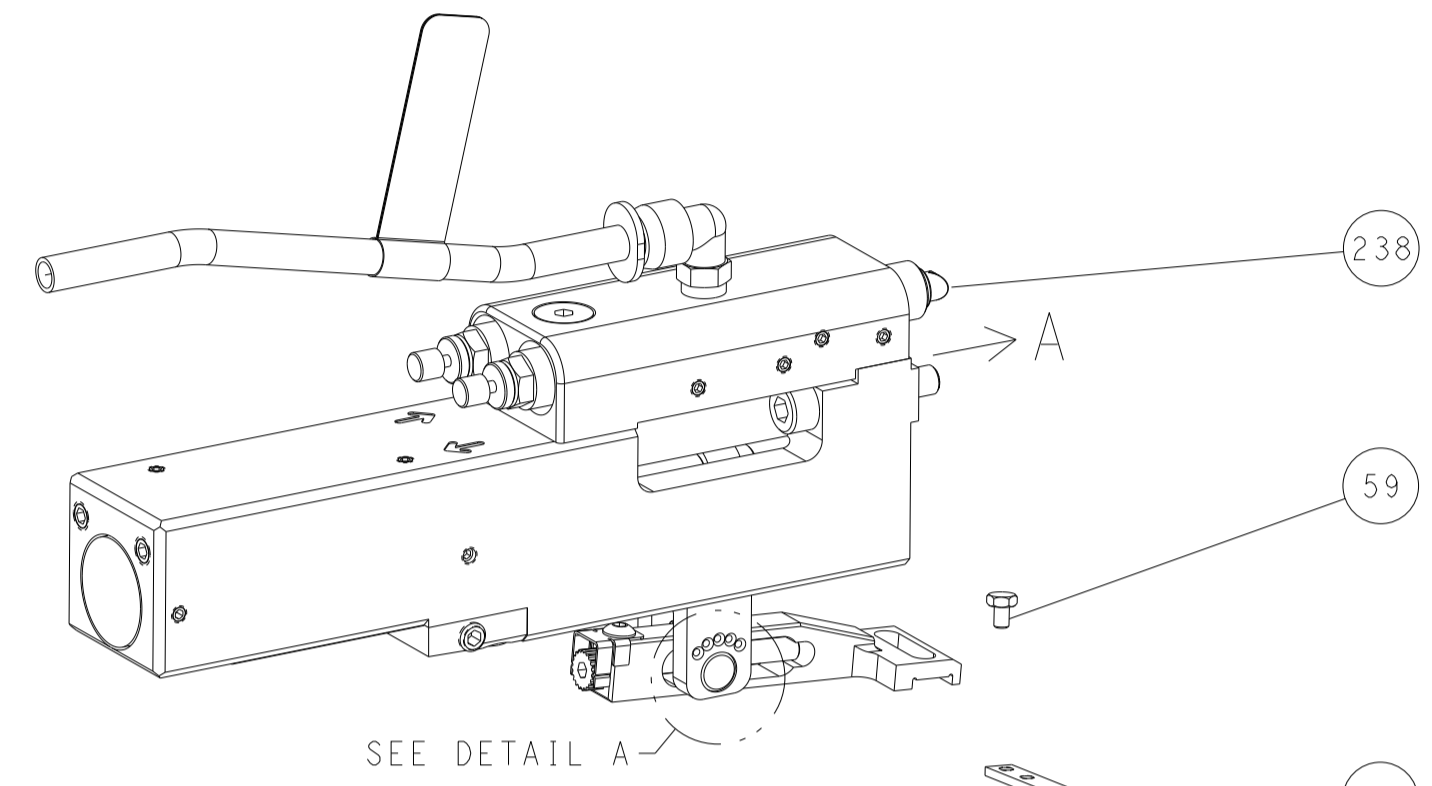

SEE DETAIL A
 FEED SPRING SETTING POSITION
 (SHOWN FROM REAR SIDE)

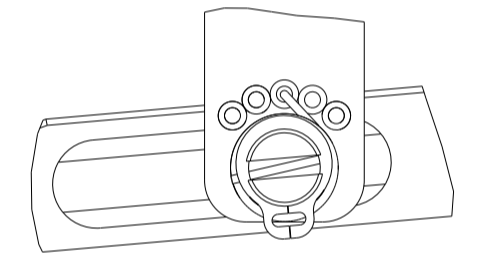

DETAIL A

DOUBLE ACTING PNEUMATIC WITH SENSORS

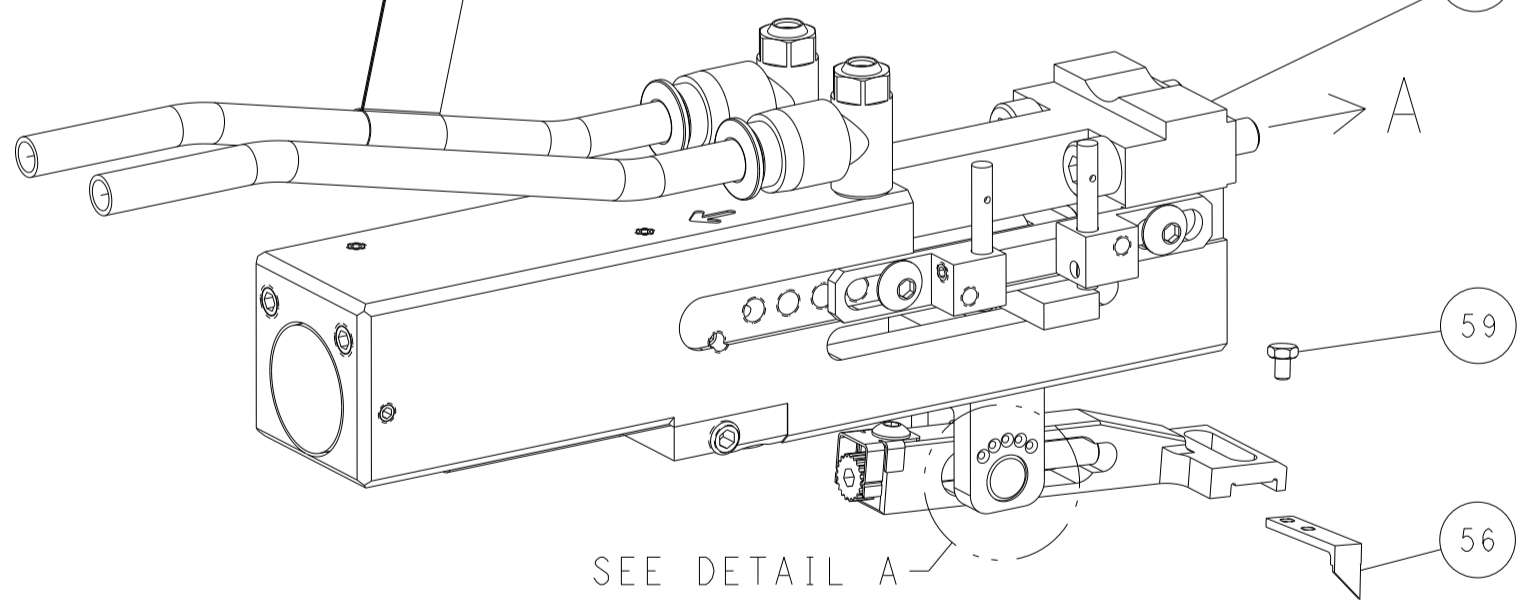

SEE DETAIL A

CAM POSITIONS

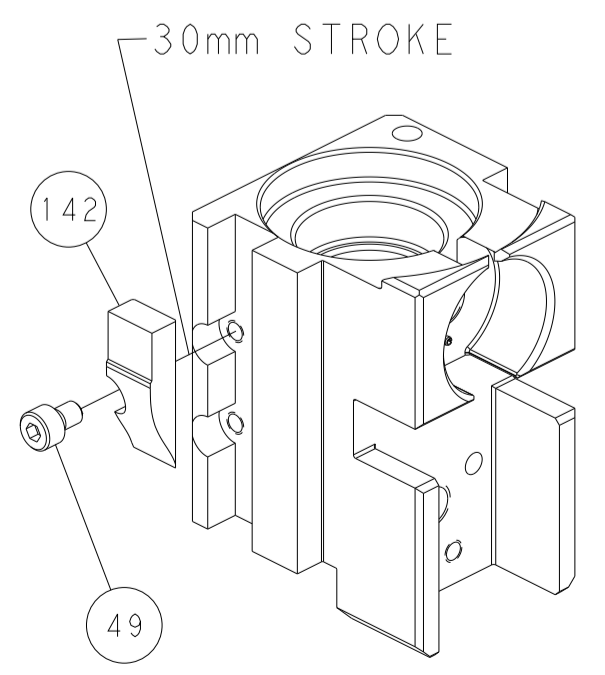

MECHANICAL
POST FEED

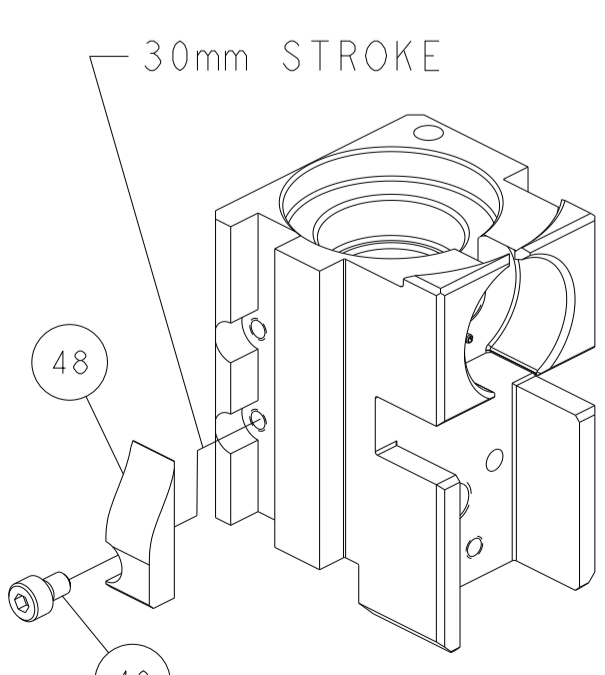

MECHANICAL
PRE FEED

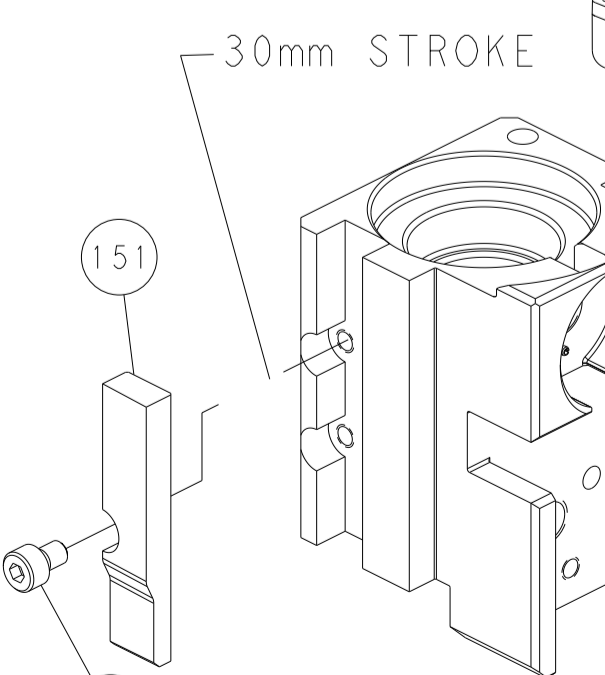

AIR FEED

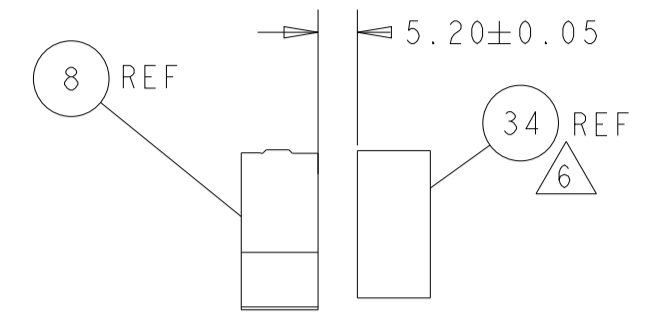
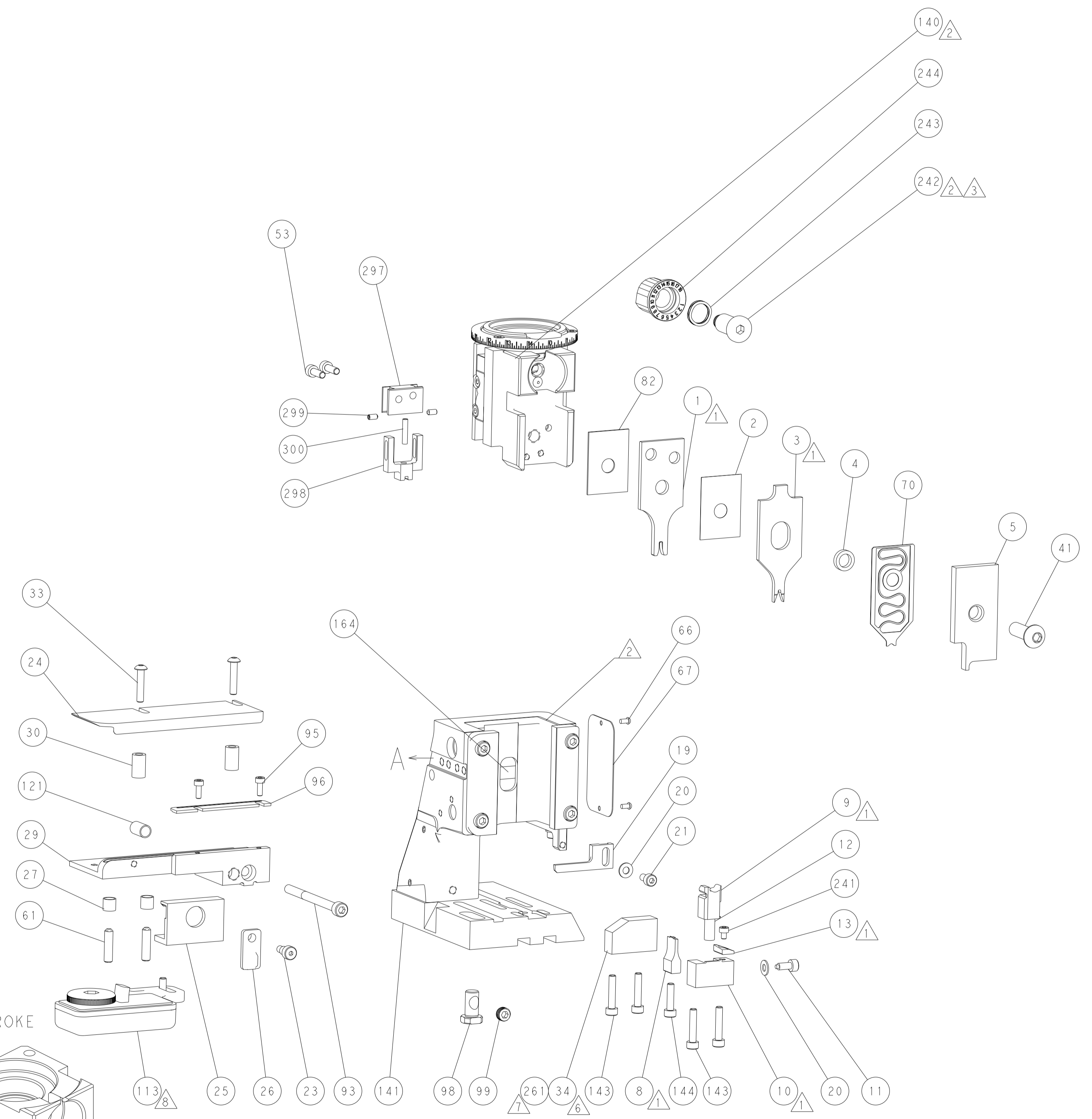

TERMINAL SUPPORT LOCATION
FOR MALE TERMINAL

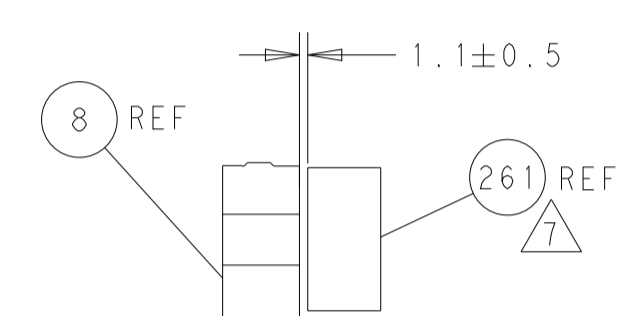

TERMINAL SUPPORT LOCATION
FOR FEMALE TERMINAL

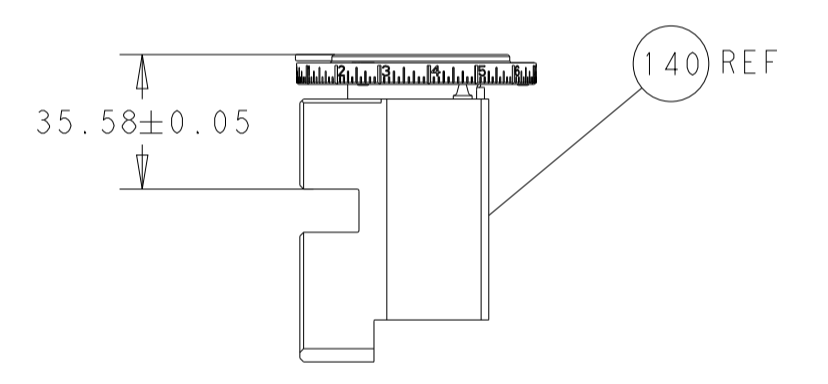

RAM SET-UP

ITEM 30 LOCATED AT
REAR HOLES

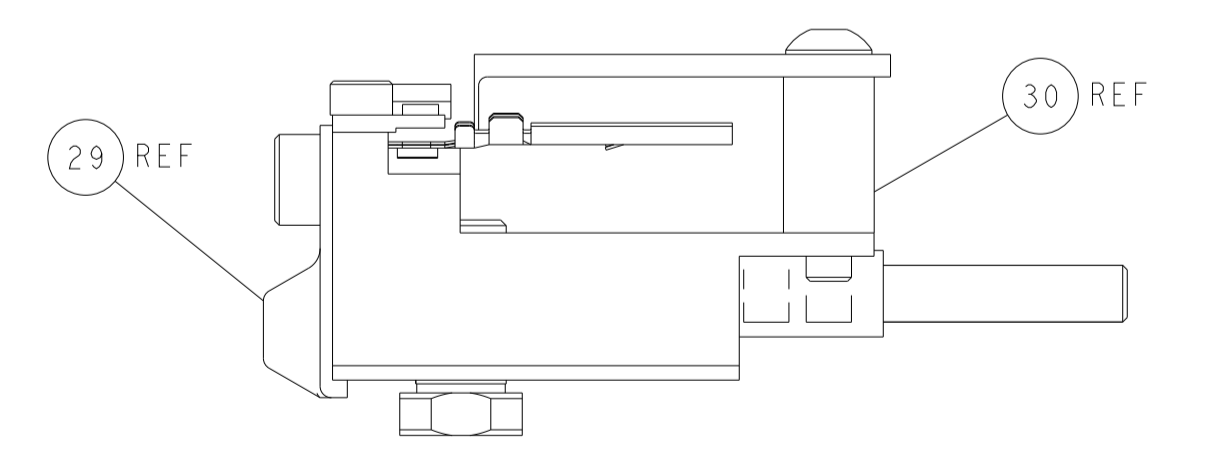

FEED TRACK POSITION
GUIDE BY INSULATION BARREL

PACIFIC VERSION
 Shown on sheets 3 of 4 & 4 of 4
 (Atlantic version shown on sheets 1 of 4 & 2 of 4)

DIMENSIONS: mm 		TOLERANCES UNLESS OTHERWISE SPECIFIED: 0 PLC ± 1 PLC ± 2 PLC ± 3 PLC ± 4 PLC ± ANGLES ± FINISH		DWN C. MOYER Z0DEC2012 CHK T. ELBIN Z0DEC2012 APVD T. ELBIN Z0DEC2012 PRODUCT SPEC APPLICATION SPEC WEIGHT Customer Accessible Production Drawing		NAME Ocean Side Feed Applier SIZE A1 CAGE CODE 00779 DRAWING NO. ©=2151539 SCALE 1:2 SHEET 4 OF 4 REV Y		RESTRICTED TO -	
-----------------------	--	--	--	--	--	---	--	--------------------	--