

SCALE 5:1

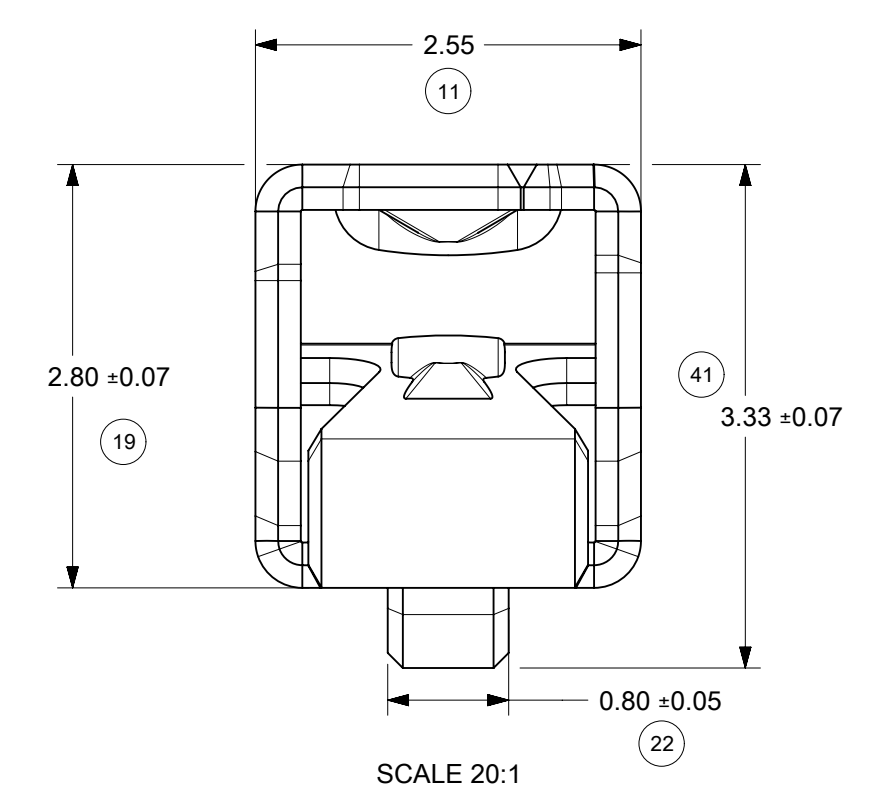
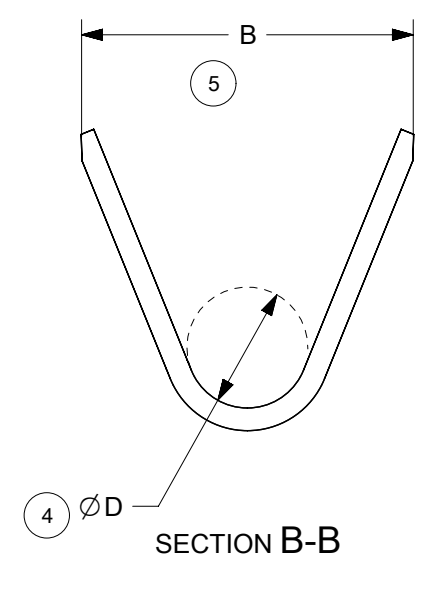
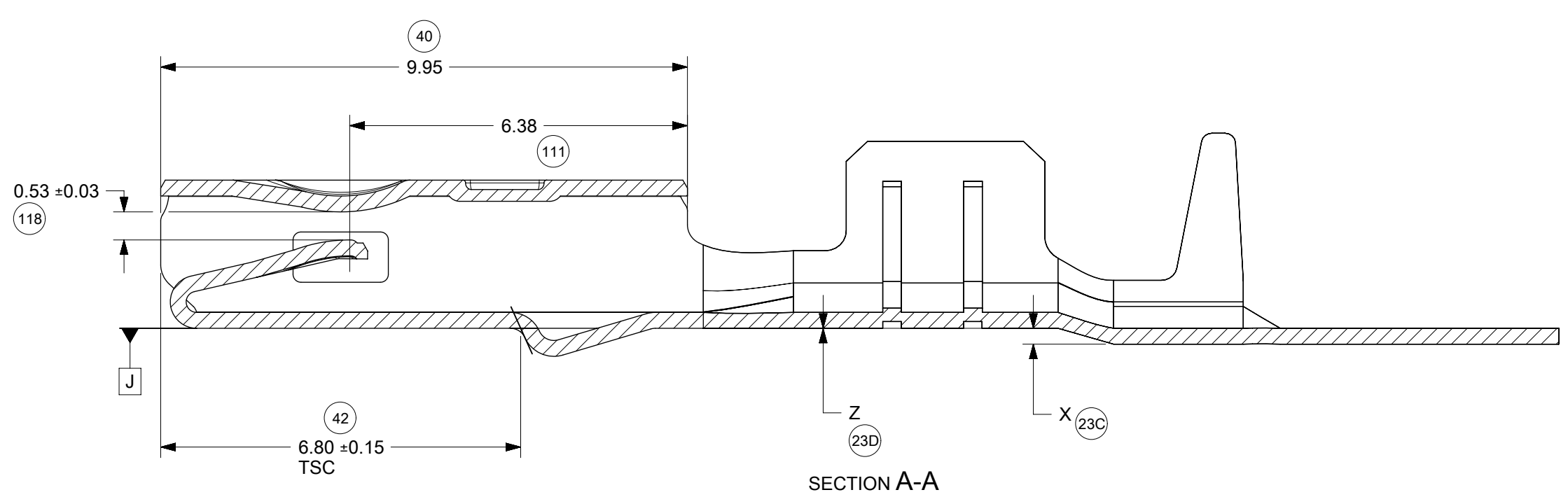

SCALE 20:1

- NOTES: (UNLESS OTHERWISE SPECIFIED)
- MATING TERMINAL SHOWN ON SD-33000-001
 - MATERIAL: COPPER ALLOY
 - PLATING SEE TABLE 1
 - PACKAGING SPECIFICATION: 313025040
 - CRIMPING SPECIFICATION: 2037704320-AS
 - PRODUCT SPECIFICATION 2037704321-PS
 - TSC ON A DIMENSION TO BE INTERPRETED AS DISTANCE TO A THEORETICAL SHARP CORNER AS IF THE RADIUS WERE NOT PRESENT
 - PROBING THE CONTACT INTERFACE OF THE TERMINAL OR AT ANY POINT ON THE TERMINAL BEAM IS NOT PERMITTED
 - MOLEX RECOMMENDED FOR USE WITH 20 CIRCUIT MX150 MAT-SEALED FEMALE CONNECTOR ASSEMBLY

TABLE 1

FAMILY	GENDER	SEALING	PLATING	PART NUMBER	PAYOFF DIRECTION	GRIP CODE	WIRE SIZES	A	B	C	D	X	Z		
MX150 Gen 2.0	RECEPTACLE	MAT SEAL	Sn	203770-2001	RIGHT (B)	14/16	14 AWG	3.9	4.5	1.7	1.6	0.30 (BELOW DTM J)	0.00		
				203770-3001	LEFT (B)		1.50 mm ²								
				203770-2002	RIGHT (B)	18/20	1.00 mm ²	3.3	3.6	1.3	1.4				
				203770-3002	LEFT (D)		0.75 mm ²								
				203770-2004	RIGHT (B)	M3	0.50 mm ²	2.5	2.7	0.9	1.54			0.15 (ABOVE DTM J)	0.30 (ABOVE DTM J)
				203770-3004	LEFT (D)		0.35 mm ²								

THIS DRAWING CONTAINS INFORMATION THAT IS PROPRIETARY TO MOLEX ELECTRONIC TECHNOLOGIES, LLC AND SHOULD NOT BE USED WITHOUT WRITTEN PERMISSION											
SYMBOLS		DIMENSION UNITS		SCALE		CURRENT REV DESC:					
▽ = 0		mm		10:1		EC NO: 653231					
▽ = 0						DRWN: MICAB 2020/12/02					
▽ = 0						CHK'D: BSKANTHARAJU 2021/01/19					
▽ = 0						APPR: JCUATACERVAN 2021/01/29					
▽ = 0						INITIAL REVISION:					
▽ = 0						DRWN: MICAB 2005/06/21					
▽ = 0						APPR: JCUATACERVAN 2005/06/22					
▽ = 0						DRAFT WHERE APPLICABLE MUST REMAIN WITHIN DIMENSIONS		THIRD ANGLE PROJECTION		DRAWING SERIES	
▽ = 0								C-SIZE		203770	
DOCUMENT STATUS				P1		RELEASE DATE		2021/01/29		19:48:05	
DOCUMENT NUMBER				2037704323		DOC TYPE		PSD		DOC PART REVISION	
MATERIAL NUMBER				SEE TABLE		CUSTOMER		GENERAL MARKET		SHEET NUMBER	
										1 OF 3	



MX150 RCPT GEN 2.0 SD RECEPTACLE TERMINAL

PRODUCT CUSTOMER DRAWING

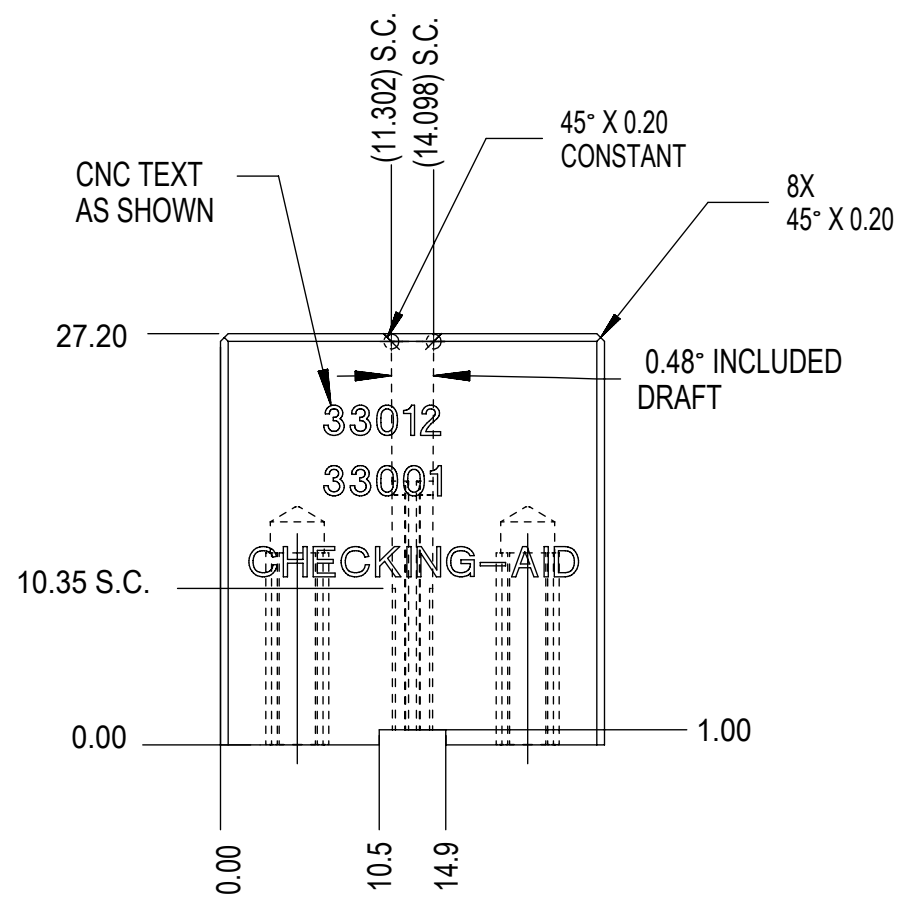
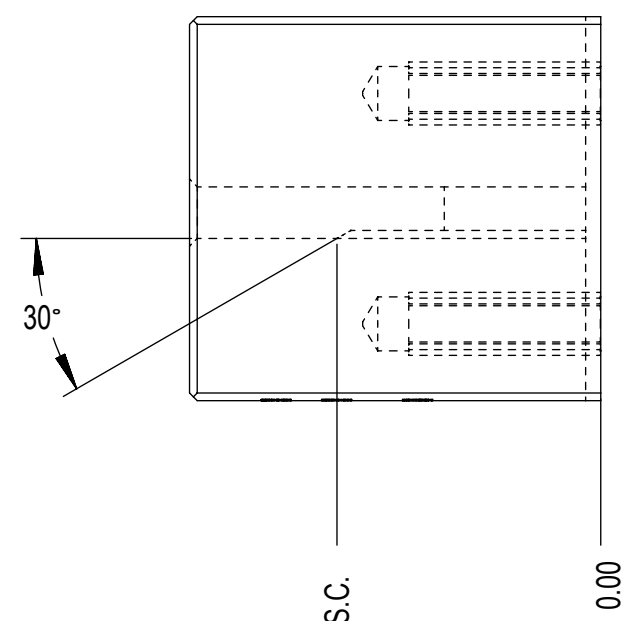
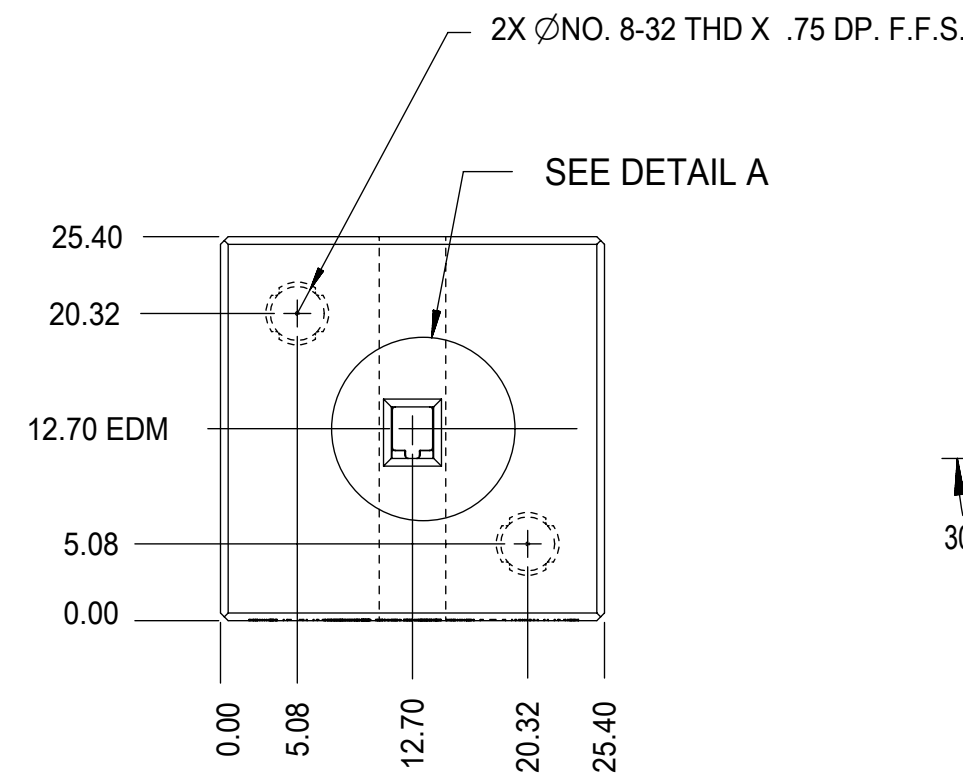

CHECKING - AID UPPER

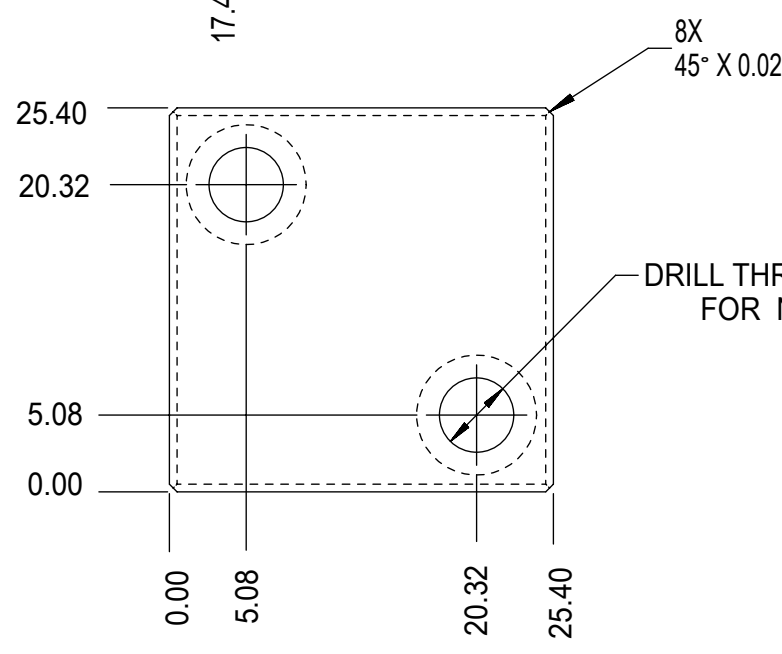

CHECKING - AID LOWER

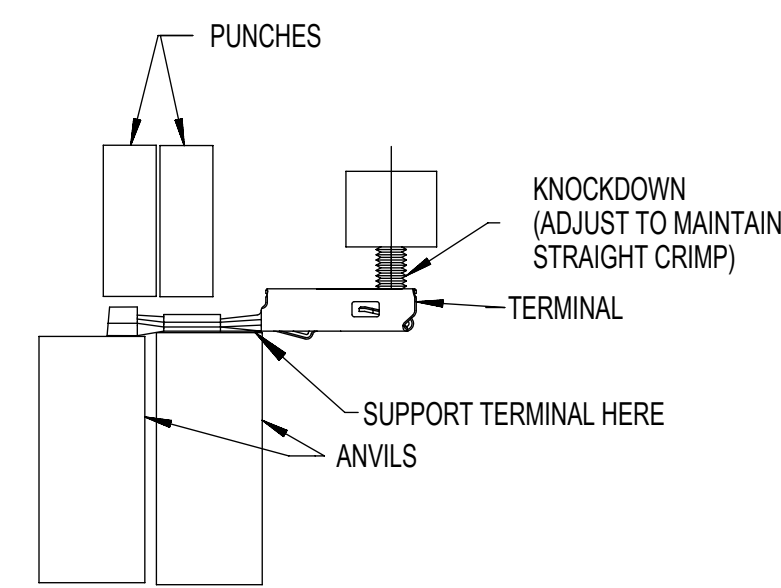

- CRIMP REQUIREMENTS:
1. CRIMP STRAIGHTNESS MUST BE MAINTAINED USE A KNOCKDOWN TOOL LOCATED AS SHOWN TERMINAL BOX MUST NOT BE DEFORMED
 2. AFTER CRIMPING, THE CRIMPED TERMINAL (AND UP TO 5 mm OF WIRE PAST THE INSULATOR CUTOFF TAB) MUST FIT FREELY INTO THE CHECKING-AID SHOWN ON THIS PAGE
 3. FOR OTHER MECHANICAL REQUIREMENTS ON CRIMPED TERMINALS, REFER TO SAE/USCAR-21 SECTIONS 4.2 (VISUAL INSPECTION), 4.3 (CROSS SECTION ANALYSIS) AND 4.4 (CONDUCTOR CRIMP PULLOUT FORCE)

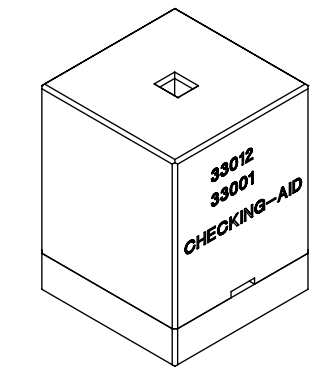

CHECKING - AID ASSEMBLY SCALE 1:1

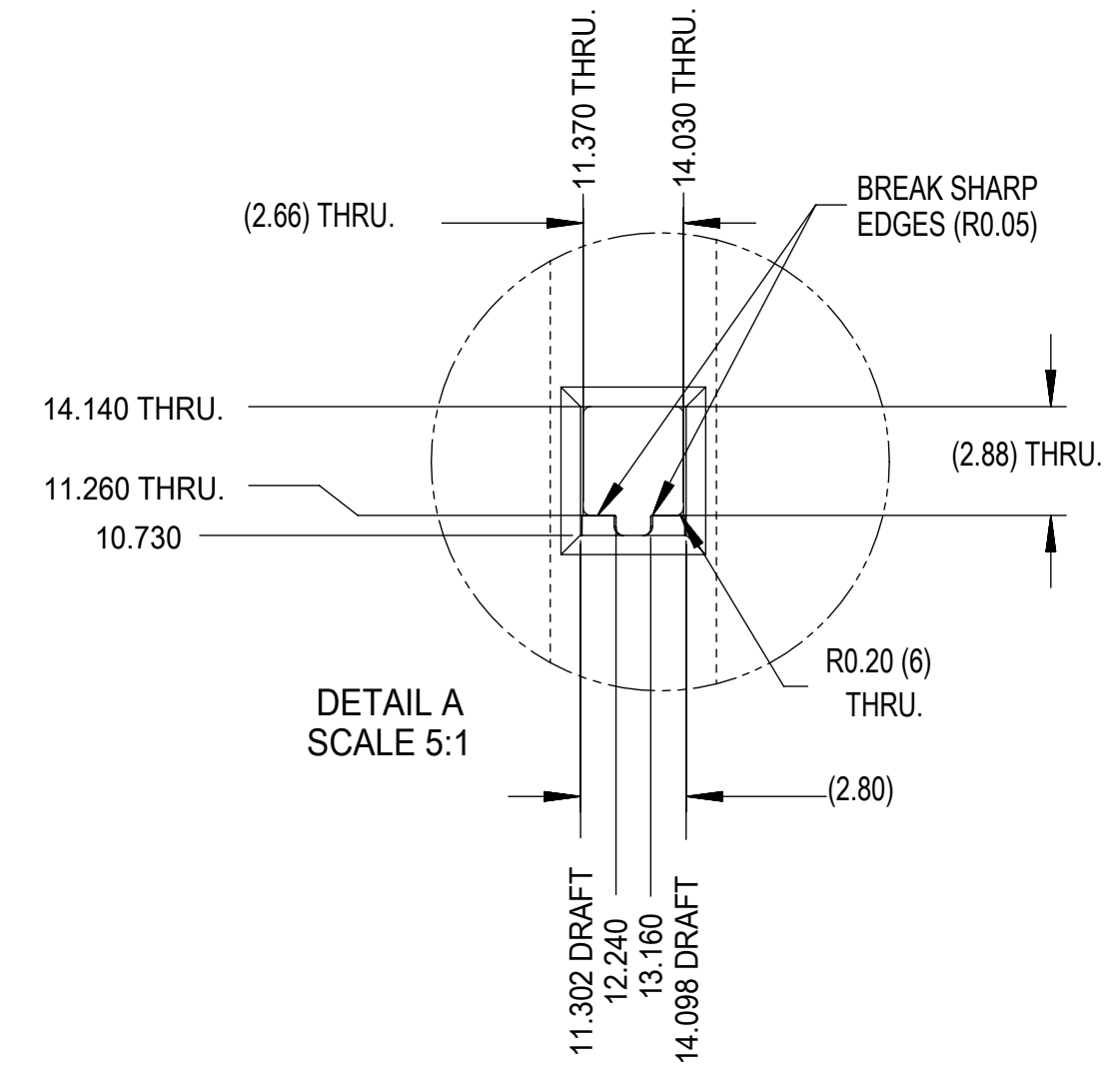

DETAIL A SCALE 5:1

UPPER & LOWER CHECKING-AID A2 TOOL STEEL HARDEN & GRIND ROCKWELL "C" 56-58

THIS DRAWING CONTAINS INFORMATION THAT IS PROPRIETARY TO MOLEX ELECTRONIC TECHNOLOGIES, LLC AND SHOULD NOT BE USED WITHOUT WRITTEN PERMISSION									
SYMBOLS		DIMENSION UNITS	SCALE	CURRENT REV DESC:					
▽ = 0	▽ = 0	mm	2:1	EC NO: 653231 DRWN: MICAB 2020/12/02 CHK'D: BSKANTHARAJU 2021/01/19 APPR: JCUATACERVAN 2021/01/29 INITIAL REVISION: DRWN: MICAB 2005/06/21 APPR: JCUATACERVAN 2005/06/22					
▽ = 0	▽ = 0	GENERAL TOLERANCES (UNLESS SPECIFIED)							
▽ = 0	▽ = 0	ANGULAR TOL ± 3.0°							
▽ = 0	▽ = 0	4 PLACES ±							
▽ = 0	▽ = 0	3 PLACES ±							
▽ = 0	▽ = 0	2 PLACES ± 0.10		PRODUCT CUSTOMER DRAWING DOCUMENT NUMBER: 2037704323 DOC TYPE: PSD DOC PART: 001 REVISION: A					
▽ = 0	▽ = 0	1 PLACE ± 0.3							
▽ = 0	▽ = 0	0 PLACES ±							
▽ = 0	▽ = 0	DRAFT WHERE APPLICABLE MUST REMAIN WITHIN DIMENSIONS		THIRD ANGLE PROJECTION	DRAWING	SERIES	MATERIAL NUMBER	CUSTOMER	SHEET NUMBER
▽ = 0	▽ = 0			C-SIZE	203770	203770	SEE TABLE	GENERAL MARKET	2 OF 3

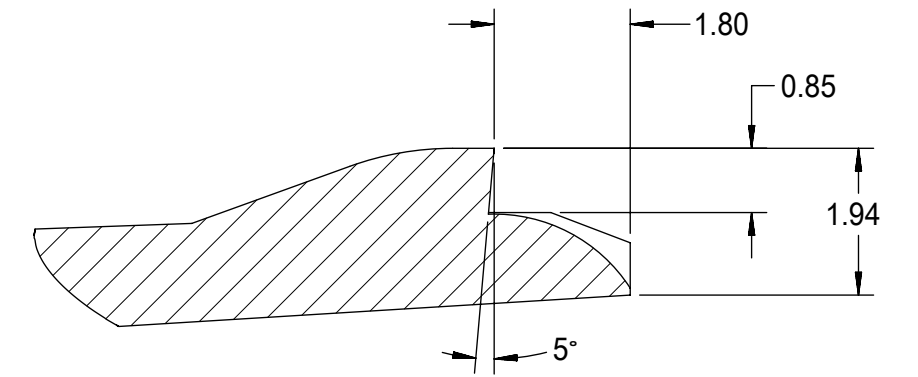
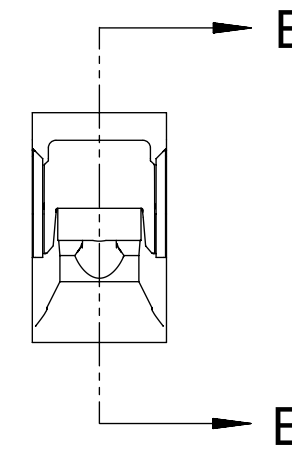
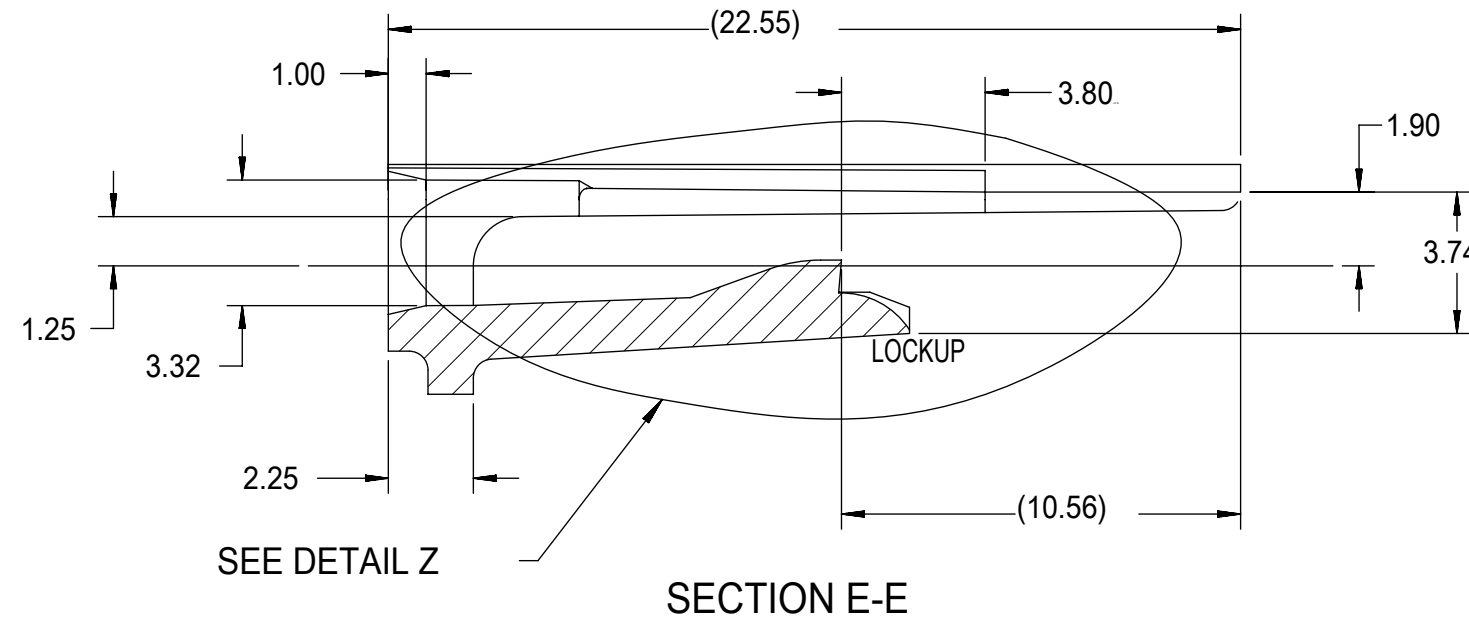
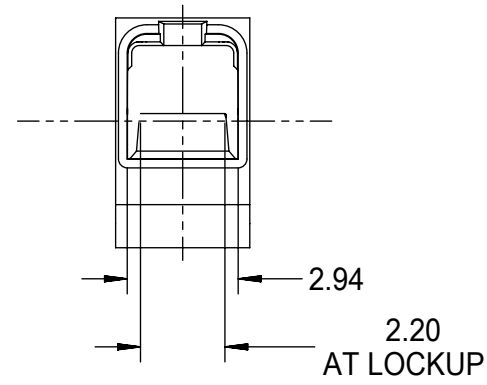
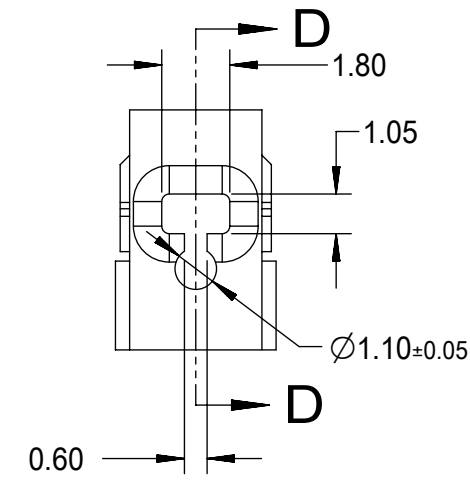
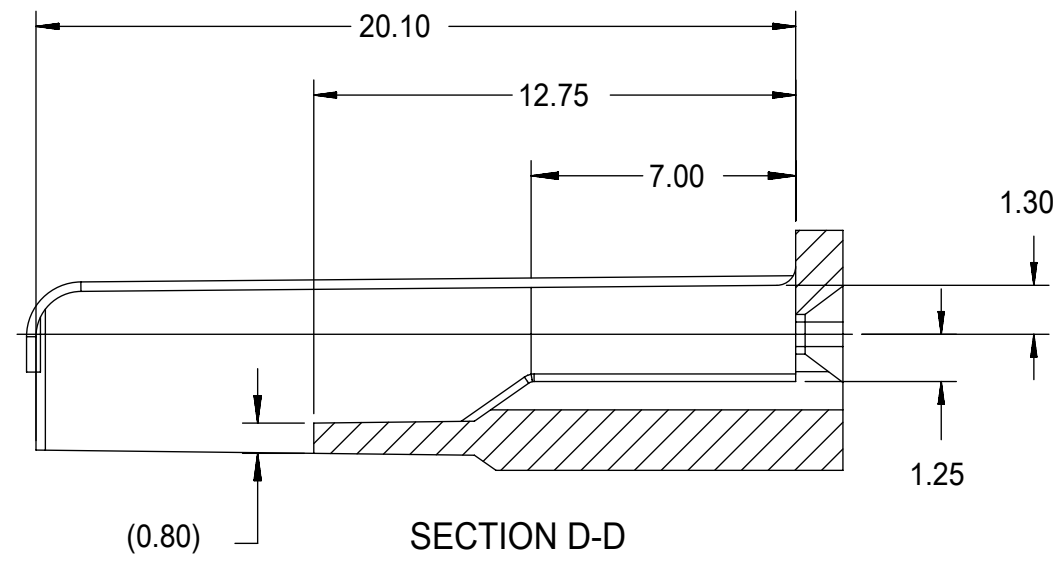
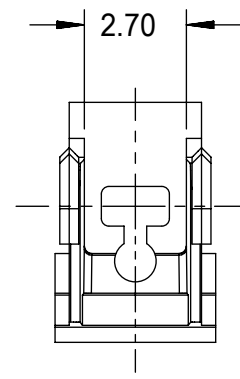

DETAIL Z
SCALE 20:1

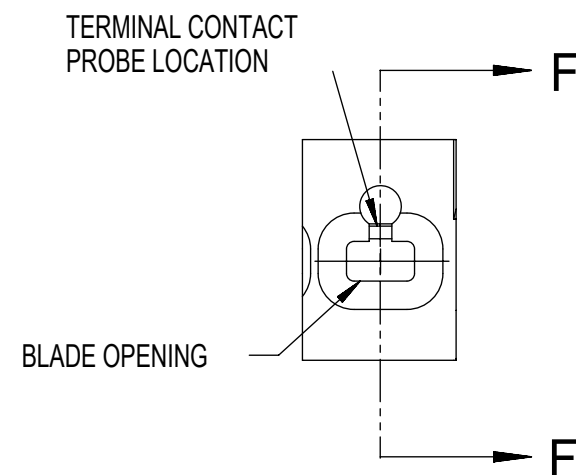
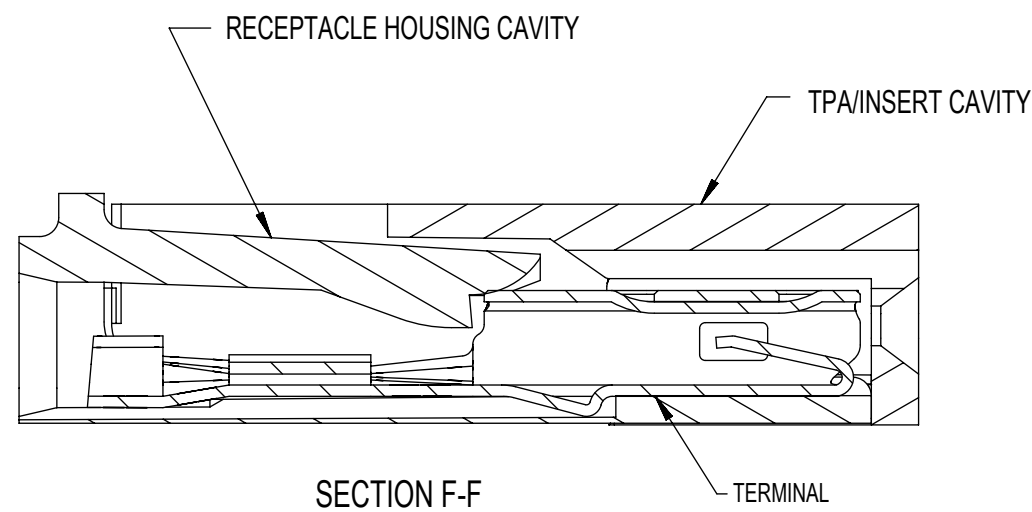

RECEPTACLE CAVITY ASSEMBLED VIEWS
FOR SMALL POLARIZATION RIB APPLICATIONS
FIG. 1

PREFERRED PROBING LOCATION
IS NOT ON SPRING MEMBER

FOR PROBING INFORMATION REFERENCE
MOLEX MX150 APPLICATION SPECIFICATION AS-33472-100

- NOTES: UNLESS OTHERWISE SPECIFIED
1. ALL DRAFT WITHIN TOLERANCE.
 2. MAX RADII ON ALL CORNERS SHOWN SHARP: 0.10
 3. MAX FLASH PERMISSIBLE: 0.1
 4. EJECTOR PIN MARKS PERMISSIBLE IF FLUSH TO 0.25 BELOW SURFACE.
 5. MATERIAL: HOUSING/FINGER SPECIFICATION ENGINEERED FOR MATERIAL WITH THE FOLLOWING PROPERTIES:
A. FLEXURAL MODULUS = 4,500 TO 9,400 MPa
PER ASTM TEST D790
B. ELONGATION AT YIELD = 2.3% OR BETTER
PER ASTM TEST D638 TYPE V
 6. CAVITY SPEC FOR USE ONLY WITH MOLEX RECEPTACLE TERMINAL PART NUMBERS SPECIFIED ELSEWHERE ON THIS DRAWING

SYMBOLS		THIS DRAWING CONTAINS INFORMATION THAT IS PROPRIETARY TO MOLEX ELECTRONIC TECHNOLOGIES, LLC AND SHOULD NOT BE USED WITHOUT WRITTEN PERMISSION	
DIMENSION UNITS	SCALE	CURRENT REV DESC:	
▽ = 0	mm	5:1	
▽ = 0	GENERAL TOLERANCES (UNLESS SPECIFIED)		
▽ = 0	ANGULAR TOL ± 3.0°		
▽ = 0	4 PLACES	±	
▽ = 0	3 PLACES	±	
▽ = 0	2 PLACES	± 0.10	
▽ = 0	1 PLACE	± 0.3	
▽ = 0	0 PLACES	±	
▽ = 0	DRAFT WHERE APPLICABLE MUST REMAIN WITHIN DIMENSIONS		
	THIRD ANGLE PROJECTION	DRAWING	SERIES
		C-SIZE	203770
	EC NO: 653231		DRWN: MICAB 2020/12/02
	CHK'D: BSKANTHARAJU 2021/01/19		APPR: JCUATACERVAN 2021/01/29
	INITIAL REVISION:		DRWN: MICAB 2005/06/21
	APPR: JCUATACERVAN 2005/06/22		
	DOCUMENT NUMBER	DOC TYPE	DOC PART
	2037704323	PSD	001
	MATERIAL NUMBER	CUSTOMER	SHEET NUMBER
	SEE TABLE	GENERAL MARKET	3 OF 3

molex

MX150 RCPT GEN 2.0 SD
RECEPTACLE TERMINAL

PRODUCT CUSTOMER DRAWING

DOCUMENT NUMBER DOC TYPE DOC PART REVISION

2037704323 PSD 001 A

MATERIAL NUMBER CUSTOMER SHEET NUMBER

SEE TABLE GENERAL MARKET 3 OF 3