

| MATERIAL NUMBER | ENGINEERING NUMBER | FINISHED LENGTH |
|-----------------|--------------------|------------------|
| 1300610143 | 104006A46M005 | 0.5M [1FT 8 IN] |
| 1300610159 | 104006A46M100 | 10M [32FT 10 IN] |
| 1300610163 | 104006A46M250 | 25M [82FT] |

(A) PART NUMBER LEGEND

104006A45M005

LENGTH:
M005= 0.5 METER
M010= 1 METER
M100= 10 METER

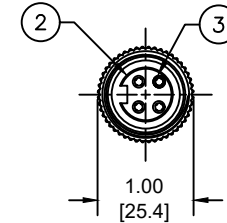
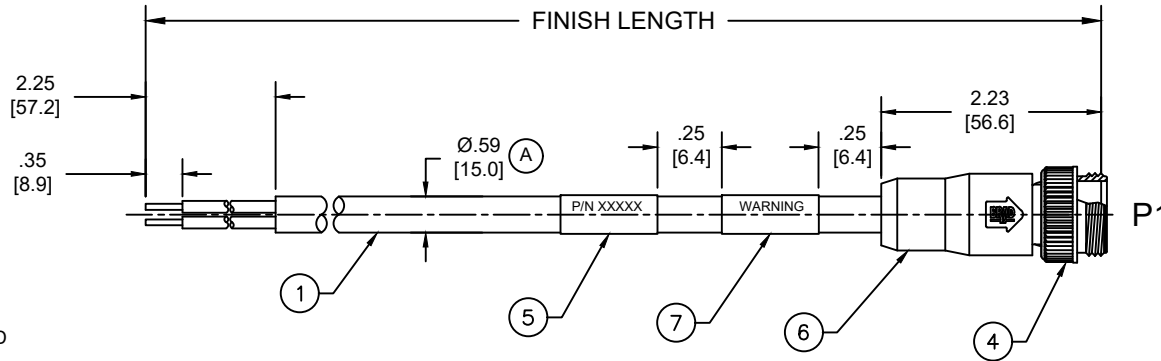
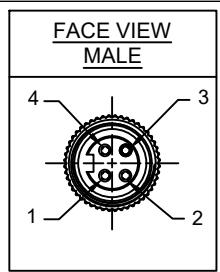
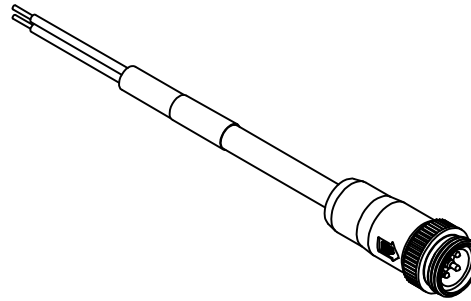

FACE VIEW - MALE

NOTES:

- MATERIAL: AS NOTED
- FINISH: AS NOTED
- ELECTRICAL:
 - VOLTAGE: 483V PER IEC60664 (A)
 - 600V PER UL2237
 - CURRENT: 15A
- TEMP RATING: -20°TO +105°C (A)
- PROTECTION: IP67 (WHEN MATED)
- COUPLING THREAD: 7/8"-16UN
- UL LISTED FILE: E258922
- ALL DIMENSIONS ARE FOR REFERENCE UNLESS TOLERANCED OR NOTED OTHERWISE

P1

| | |
|--------------|---|
| BLACK | 1 |
| WHITE | 2 |
| RED | 3 |
| GREEN/YELLOW | 4 |

WIRING DIAGRAM

(A)

| CABLE LENGTH TOLERANCES | |
|--------------------------|-------------------------|
| <.3M [1FT]: | +19mm-0 [+ .75in-0] |
| .3 - .9M [1 - 3FT]: | +44.5mm-0 [+1.75in-0] |
| .9 - 1.8M [3 - 6FT]: | +55.6mm-0 [+2.19in-0] |
| 1.8 - 3.7M [6 - 12FT]: | +88.9mm-0 [+3.50in-0] |
| 3.7 - 7.3M [12 - 24FT]: | +165.1mm-0 [+6.50in-0] |
| 7.3-14.6M [24 - 48FT]: | +317.5mm-0 [+12.50in-0] |
| 14.6 - 30.5M [48-100FT]: | +622.3mm-0 [+24.50in-0] |
| OVER 30M [100FT] | +2% OF FINISHED LENGTH |

| ITEM | DESCRIPTION | MATERIAL | FINISH |
|------|---------------|------------|------------------|
| 7 | WARNING LABEL | VINYL | BLACK |
| 6 | OVERMOLD | TPE | GRAY |
| 5 | WRAP LABEL | VINYL | YELLOW |
| 4 | COUPLING NUT | ZINC ALLOY | BLACK E-COAT |
| 3 | PIN CONTACT | BRASS | GOLD OVER NICKEL |
| 2 | INSERT | TPE | BLACK |
| 1 | #14/4 CABLE | PVC JACKET | GRAY |

| FUNCTIONAL SYMBOLS $F_A=0$ $F_C=0$ $F_P=0$ | DIMENSION UNITS: INCH/MM SCALE: NTS | | CURRENT REV DESC: ITEM 2 & 6 WERE PVC. ADDED IEC VOLTAGE, PN MATRIX, CABLE DIA & TOL CHART. MODIFIED TEMP RATING AND PN TABLE. | | <p>BRAD POWER CORDSET, A-SIZE 4-POLE, MALE, STRAIGHT, SINGLE KEY, #14 AWG</p> | | | | | | | | | | | | | | | | | | |
|--|--|--|--|--|---|------|----------|-------|-------|----------|-------|-------|----------|-------|-------|---------|-------|-------|----------|-------|-------|--|--|
| | GENERAL TOLERANCES (UNLESS SPECIFIED) | | EC NO: 698916 DRWN: ABENJAMINLW 2021/06/17 CHK'D: RSTONE 2022/03/09 APPR: BWOODMAN 2022/03/11 | | | | | | | | | | | | | | | | | | | | |
| | <table border="1"> <thead> <tr> <th></th> <th>mm</th> <th>INCH</th> </tr> </thead> <tbody> <tr> <td>4 PLACES</td> <td>±----</td> <td>±----</td> </tr> <tr> <td>3 PLACES</td> <td>±----</td> <td>±----</td> </tr> <tr> <td>2 PLACES</td> <td>±----</td> <td>±----</td> </tr> <tr> <td>1 PLACE</td> <td>±----</td> <td>±----</td> </tr> <tr> <td>0 PLACES</td> <td>±----</td> <td>±----</td> </tr> </tbody> </table> | | | mm | | INCH | 4 PLACES | ±---- | ±---- | 3 PLACES | ±---- | ±---- | 2 PLACES | ±---- | ±---- | 1 PLACE | ±---- | ±---- | 0 PLACES | ±---- | ±---- | INITIAL REVISION: DRWN: VOU 2010/01/14 APPR: JFMURPHY 2010/01/20 | |
| | | mm | INCH | | | | | | | | | | | | | | | | | | | | |
| 4 PLACES | ±---- | ±---- | | | | | | | | | | | | | | | | | | | | | |
| 3 PLACES | ±---- | ±---- | | | | | | | | | | | | | | | | | | | | | |
| 2 PLACES | ±---- | ±---- | | | | | | | | | | | | | | | | | | | | | |
| 1 PLACE | ±---- | ±---- | | | | | | | | | | | | | | | | | | | | | |
| 0 PLACES | ±---- | ±---- | | | | | | | | | | | | | | | | | | | | | |
| ANGULAR TOL ± ---- ° | | DRAFT WHERE APPLICABLE MUST REMAIN WITHIN DIMENSIONS | | THIRD ANGLE PROJECTION | | | | | | | | | | | | | | | | | | | |
| DOCUMENT STATUS: P1 RELEASE DATE: 2022/03/11 14:29:47 | | DRAWING: A-SIZE SERIES: 130061 | | MATERIAL NUMBER: SEE CHART CUSTOMER: GENERAL MARKET SHEET NUMBER: 1 OF 1 | | | | | | | | | | | | | | | | | | | |