

KEINE SCHARFEN KANTEN ERLAUBT
NO SHARP EDGES PERMITTED

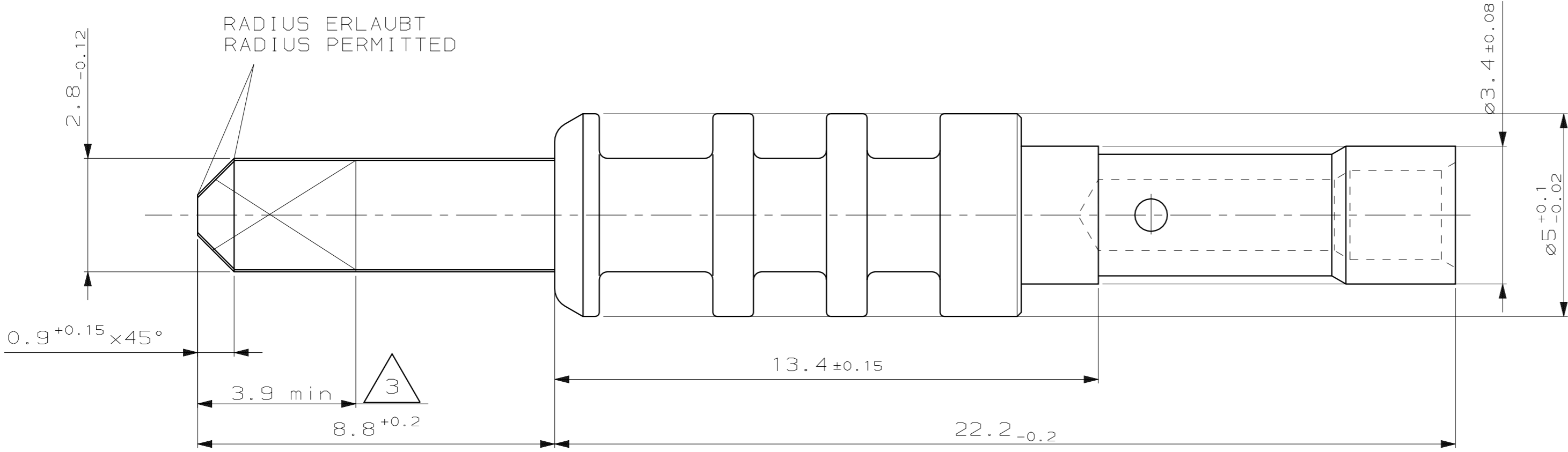

RADIUS ERLAUBT
RADIUS PERMITTED

- Bemerkungen
NOTES
- 1 1.27-2µm unternickelt auf der ganzen Fläche
1.27-2µm NICKEL UNDERPLATE
 - 2 Messpunkt für Galvanik
MEASURE-POINT FOR ELECTROPLATE
 - 3 Beidseitig min 0.8µm Au
SIDE BOTH MIN 0.8µm Au
 - 4 Min. 0.3µm SnPb7 im Überzugsbereich nach
MIN 0.3µm Sn Pb7 IN LOCALIZED PLATE

NUR FUER VW



<small>THIS DRAWING IS A CONTROLLED DOCUMENT FOR AMP INCORPORATED. IT IS SUBJECT TO CHANGE AND THE CONTROLLING ENGINEERING ORGANIZATION SHOULD BE CONTACTED FOR THE LATEST REVISION. DIESES ZEICHNUNGSDOCUMENT WIRD DURCH AMP INCORPORATED KONTROLLIERT. ÄNDERUNGEN, DIE DEM TECHNISCHEN FORTSCHRITT DIENEN, SIND VORBEHALTEN. DEN JEWEILS LETZTSTÄNDIGEN ÄNDERUNGSSTAND BEFOLGEN SIE AUF AMFAGE.</small>		DWN Augustiniak 07.05.97	AMP AMP Deutschland GmbH D - 63225 Langen	
DIMENSIONS: mm TOLERANCES UNLESS OTHERWISE SPECIFIED: ALLGEMEINTOLERANZEN 0 PLC ±- 1 PLC ±- 2 PLC ±- 3 PLC ±- ANGLES/WINKEL ±- FINISH/OBERFLÄCHE/FARBE -		CHK Nebe 09.05.97	PRODUCT SPEC. PRODUKTSPEZ. APPLICATION SPEC. VERARBEITUNGSSPEZ.	
MATERIAL		APVD	SIZE	RESTRICTED TO NUR FUER
		-	A2 00779	-
		WEIGHT	DRAWING NO. ZEICHNUNGS-NR.	
		-	C-964288	
		CUSTOMER DRAWING /KUNDENZEICHNUNG	MASSSTAB 10:1	BLATT 1 OF 1
			REV D	