

THIS DRAWING IS UNPUBLISHED. RELEASED FOR PUBLICATION
 © COPYRIGHT - By - ALL RIGHTS RESERVED.

LOC		DIST		REVISIONS			
P	LTR	DESCRIPTION		DATE	DWN	APVD	
BD	36	G1	REVISED PER ECO-13-008672		31AUG2013	KH	DR

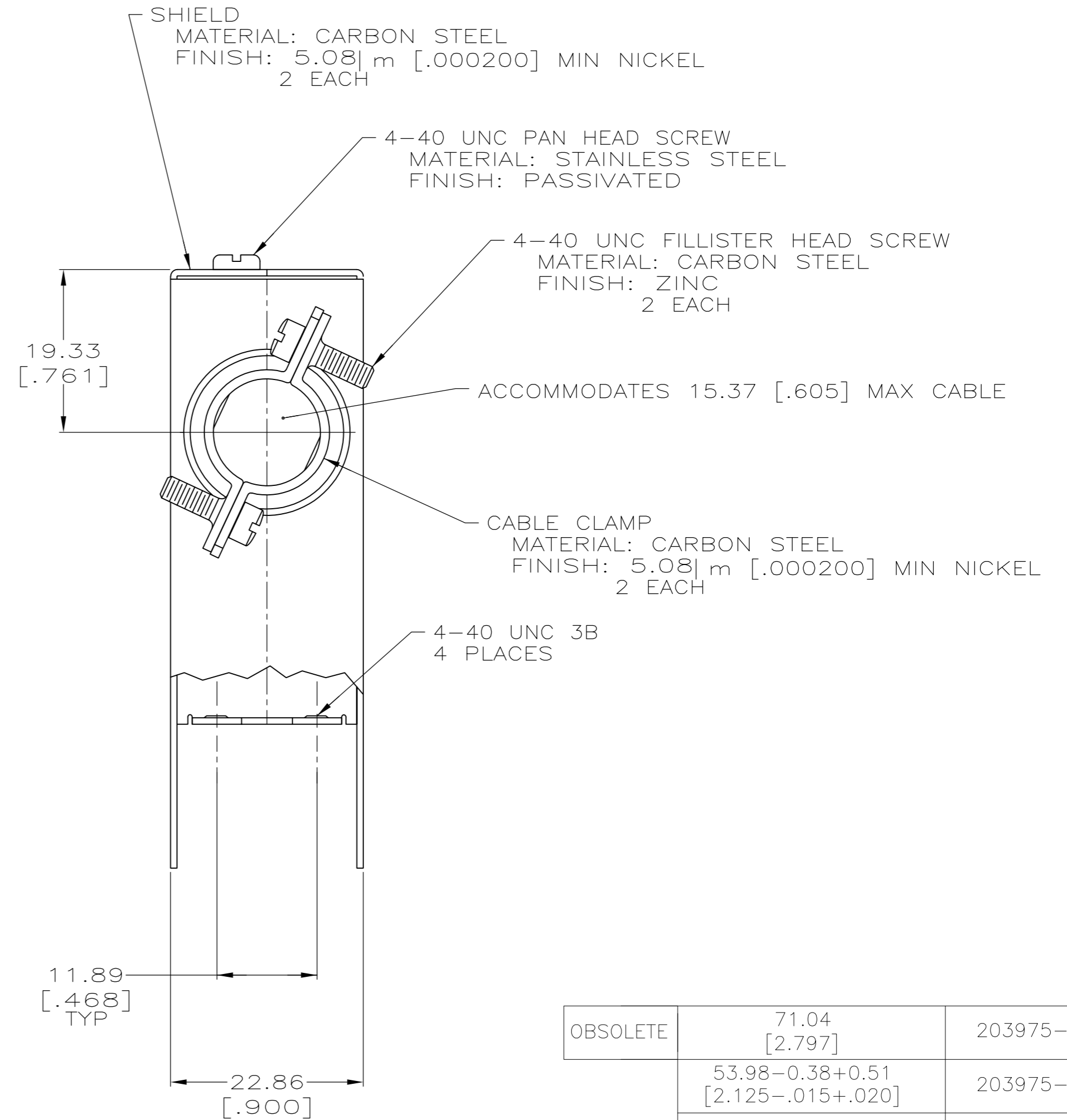
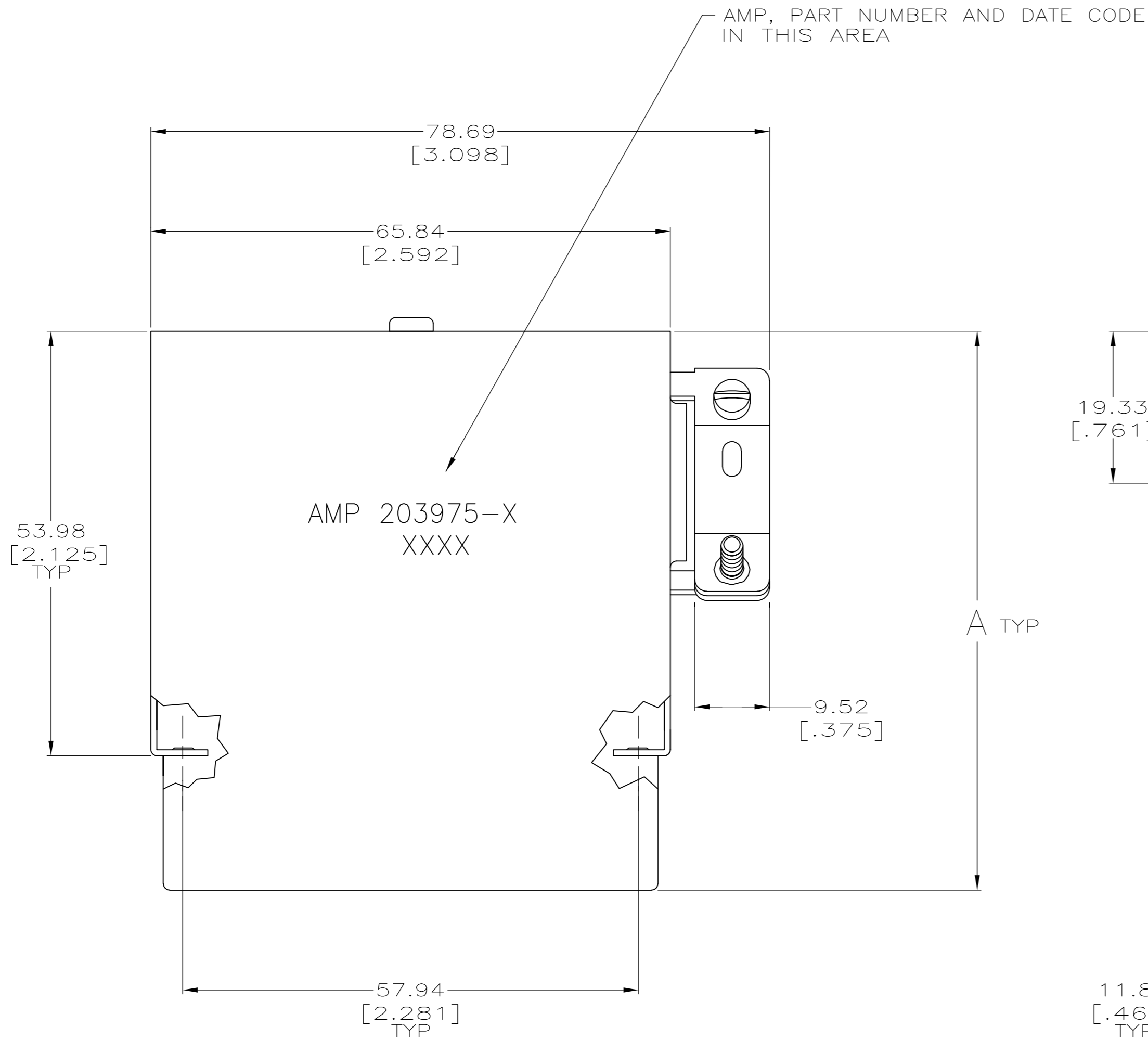

OBSOLETE	71.04 [2.797]	203975-2
	53.98-0.38+0.51 [2.125-.015+.020]	203975-1
	A	PART NUMBER

THIS DRAWING IS A CONTROLLED DOCUMENT.		DWN	C.DORWART	28 SEP 95	 TE Connectivity			
DIMENSIONS: mm [INCHES]		CHK	R.STONE	02 OCT 95				
TOLERANCES UNLESS OTHERWISE SPECIFIED:		APVD	G.STEINHAUER	04 OCT 95				
0 PLC ± - 1 PLC ± - 2 PLC ± 0.38 [.015] 3 PLC ± - 4 PLC ± - ANGLES ± -		PRODUCT SPEC	NAME					
MATERIAL SEE CALLOUTS		FINISH SEE CALLOUTS	APPLICATION SPEC		SIZE	CAGE CODE	DRAWING NO	RESTRICTED TO
		WEIGHT	-		A2	00779	C=203975	-
		CUSTOMER DRAWING		SCALE	2:1	SHEET	1 OF 1	REV
								G1