

**Order Number
203702-5200**

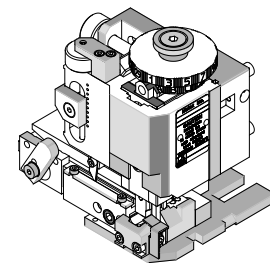

Application Tooling Specification

FEATURES

- Quick punch removal with the push of a button for fast and easy tooling change
- Applicator designed to industry-standard mounting and 135.80mm (5.346") shut height
- Quick setup time; plus, the crimp height, track and feed adjustments can be set without removing the applicator from the press
- Fine adjustment allows users to achieve target with little effort by adjusting in increments of 0.015mm (.0006") for conductor crimp height and 0.063mm (.0025") for insulation height
- Independent adjustment rings allow users to quickly adjust the conductor or insulation crimp height without affecting each other
- Directly adapts to most automatic wire processing machines
- For 14 AWG Versa-Blade terminals, use FineAdjust applicator 203702-5100

SCOPE

Products: Versa-Blade Male and Female Crimp Terminals, 16-18 AWG UL3321 heat-resistant wires.

Terminal Series No.	Terminal Order No.	Wire Size		Insulation Diameter		Strip Length	
		AWG	Wire Type	mm	In.	mm	In.
217347	217347-8000	16-18	UL3321	3.5mm max	.138 max	4.0-4.8	.16-.19
217348	217348-8000						

DEFINITION OF TERMS

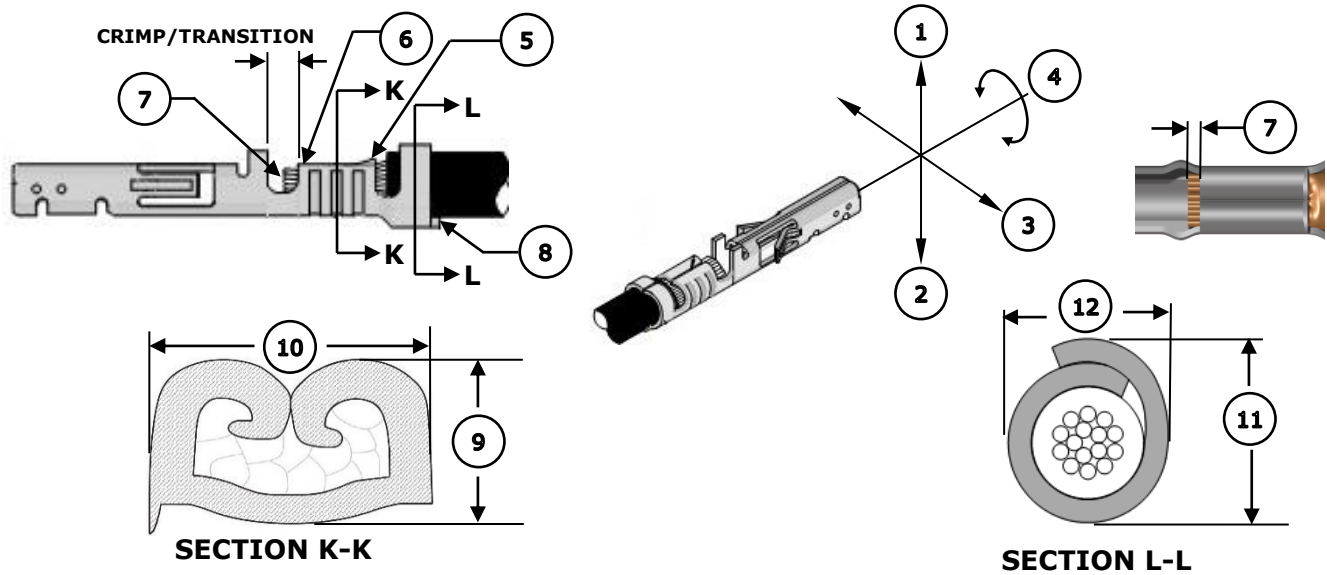

Note: Image above is a generic terminal representation. The actual terminals of the scope may look different.

CRIMP SPECIFICATION

Feature	Requirement																		
1. Bend Up	3° Max																		
2. Bend Down	3° Max																		
3. Twist	3° Max																		
4. Roll	5° Max																		
5. Bell Mouth Rear	0.30-0.80mm (.012-.031")																		
6. Bell Mouth Front	Not Applicable																		
7. Conductor Brush	0.30-1.20mm (.012-.047")																		
8. Cut-Off Tab	0.50mm (.020") Max																		
Conductor Crimp	<table border="1"> <thead> <tr> <th>Terminal Order No.</th> <th>Wire Size</th> <th colspan="2">9. Crimp Height</th> <th colspan="2">10. Crimp Width (Ref)</th> </tr> </thead> <tbody> <tr> <td>217347-8000</td> <td>16 AWG</td> <td>1.25-1.35mm</td> <td>.049-.053 In.</td> <td>2.45mm</td> <td>.096 In.</td> </tr> <tr> <td>217347-8000</td> <td>18 AWG</td> <td>1.05-1.15mm</td> <td>.041-.045 In.</td> <td>2.45mm</td> <td>.096 In.</td> </tr> </tbody> </table>	Terminal Order No.	Wire Size	9. Crimp Height		10. Crimp Width (Ref)		217347-8000	16 AWG	1.25-1.35mm	.049-.053 In.	2.45mm	.096 In.	217347-8000	18 AWG	1.05-1.15mm	.041-.045 In.	2.45mm	.096 In.
	Terminal Order No.	Wire Size	9. Crimp Height		10. Crimp Width (Ref)														
217347-8000	16 AWG	1.25-1.35mm	.049-.053 In.	2.45mm	.096 In.														
217347-8000	18 AWG	1.05-1.15mm	.041-.045 In.	2.45mm	.096 In.														
Insulation Crimp ▲	<table border="1"> <thead> <tr> <th>Terminal Order No.</th> <th>Wire Size</th> <th colspan="2">11. Crimp Height (Ref)</th> <th colspan="2">12. Crimp Width (Ref)</th> </tr> </thead> <tbody> <tr> <td>217347-8000</td> <td>16 AWG</td> <td>3.50mm</td> <td>.138 In.</td> <td>3.20mm</td> <td>.126 In.</td> </tr> <tr> <td>217347-8000</td> <td>18 AWG</td> <td>3.30mm</td> <td>.130 In.</td> <td>3.20mm</td> <td>.126 In.</td> </tr> </tbody> </table>	Terminal Order No.	Wire Size	11. Crimp Height (Ref)		12. Crimp Width (Ref)		217347-8000	16 AWG	3.50mm	.138 In.	3.20mm	.126 In.	217347-8000	18 AWG	3.30mm	.130 In.	3.20mm	.126 In.
	Terminal Order No.	Wire Size	11. Crimp Height (Ref)		12. Crimp Width (Ref)														
217347-8000	16 AWG	3.50mm	.138 In.	3.20mm	.126 In.														
217347-8000	18 AWG	3.30mm	.130 In.	3.20mm	.126 In.														
Pull Force	<table border="1"> <thead> <tr> <th>Terminal Order No.</th> <th>Wire Size</th> <th colspan="2">Minimum Pull Force</th> <th rowspan="2">To be measured with no influence from the insulation crimp.</th> </tr> </thead> <tbody> <tr> <td>217347-8000</td> <td>16 AWG</td> <td>127.5 N</td> <td>28.7 lbs.</td> </tr> <tr> <td>217347-8000</td> <td>18 AWG</td> <td>98.1 N</td> <td>22 lbs.</td> </tr> </tbody> </table>	Terminal Order No.	Wire Size	Minimum Pull Force		To be measured with no influence from the insulation crimp.	217347-8000	16 AWG	127.5 N	28.7 lbs.	217347-8000	18 AWG	98.1 N	22 lbs.					
	Terminal Order No.	Wire Size	Minimum Pull Force		To be measured with no influence from the insulation crimp.														
217347-8000	16 AWG	127.5 N	28.7 lbs.																
217347-8000	18 AWG	98.1 N	22 lbs.																

Tool Qualification Notes

1. Pull force should be measured with no influence from the insulation crimp.
2. The above specifications are guidelines to an optimum crimp.

▲ Insulation Crimp Note

Due to the terminal's insulation grip design or insulation diameter range, this applicator uses overlap form geometry in the insulation punch. This produces an overlap insulation crimp (IPC/WHMA-A-620 compliant). Although the insulation punch profile may appear lopsided, this is a normal condition for this tool. See figure to the right.

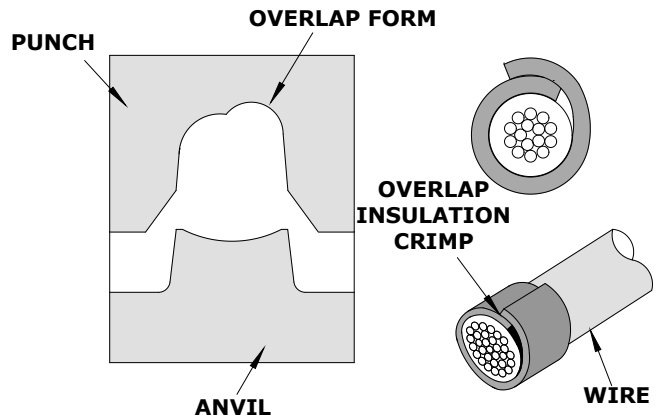

PARTS LIST

FineAdjust Applicator 203702-5200				
Item	Order No.	Engineering No.	Description	Quantity
Perishable Tooling				
	203702-5270	203702-5270	Tool Kit (All "Y" Items)	REF
1	63444-2425	63444-2425	Conductor Punch	1 Y
2	63445-2449	63445-2449	Conductor Anvil	1 Y
3	200220-3101	200220-3101	Insulation Punch	1 Y
4	200221-3101	200221-3101	Insulation Anvil	1 Y
5	63443-0002	63443-0002	Cut-Off Plunger	1 Y
6	63443-0012	63443-0012	Front Plunger Retainer	1 Y
Other Components				
7	11-17-0022	1739-21	Compression Spring	1
8	11-18-4083	60707-8	Feed Guide	1
9	11-24-1067	4996-4	Cut-Off Plunger Spring	1
10	63443-0009	63443-0009	Front Scrap Chute	1
11	63443-0024	63443-0024	Key	1
12	63443-0090	63443-0090	Wire Stop	1
13	63443-0093	63443-0093	Shank	1
14	200213-7530	200213-7530	Anvil Mount	1
15	63443-2801	63443-2801	Front Plunger Striker	1
16	63443-2913	63443-2913	Wire Hold Down Plunger	1
17	63443-7115	63443-7115	Terminal Hold Down	1
18	63443-6119	63443-6119	Rear Cover	1
19	63600-0021	63600-0021	Compression Spring	1
Frame				
20	63800-4901	63800-4901	Top	1
21	63801-3281	63801-3281	Base	1
22	63801-4650	63801-4650	Track	1
Hardware				
23	—	—	M3 by 6 Long SHCS	2*
24	—	—	M3 by 6 Long FHCS	1*
25	—	—	M3 by 8 Long SHCS	1*
26	—	—	M4 by 6 Long SHCS	2*
27	—	—	M4 by 12 Long BHCS	2*
28	—	—	M4 by 50 Long SHCS	2*
29	—	—	M5 by 12 Long SHCS	1*
30	—	—	M5 by 10 Long Flat Point SSS	1*
31	—	—	M5 Hex Jam Nut	1*

* Available from an industrial supply company.

ASSEMBLY DRAWING

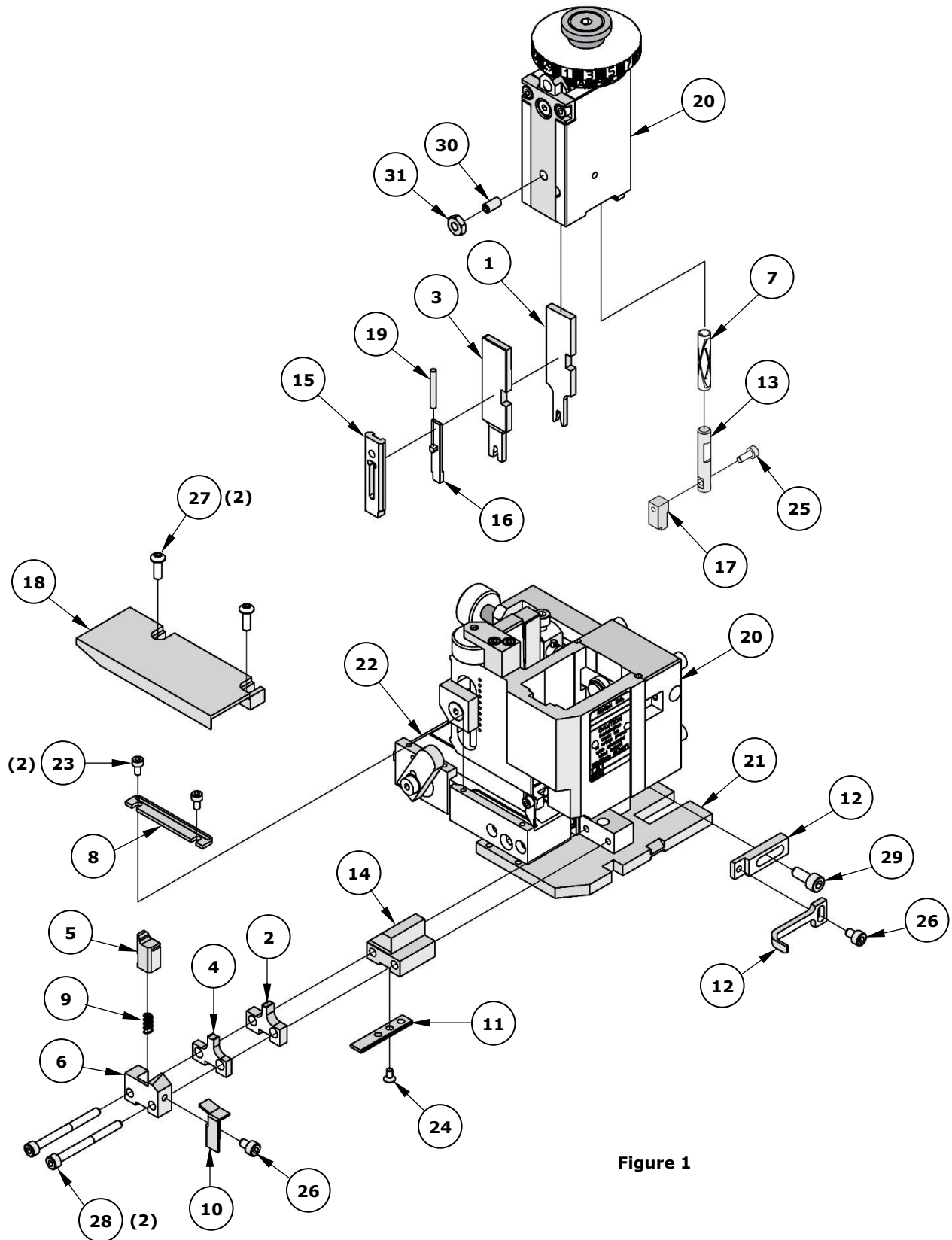

Figure 1

NOTES

1. Molex recommends that an extra perishable tooling kit be maintained at your facility.
2. Verify tooling alignment by manually cycling the press and applicator before crimping under power. Check that all screws are tight.
3. Slugs, terminals, dirt and oil should be kept clear of the work area.
4. Wear safety glasses at all times.
5. For recommended maintenance, refer to the FineAdjust manual.

CAUTION: This applicator should only be used in a press with a shut height of 135.8mm (5.346"). Tooling damage could result at a lower setting.

CAUTION: To prevent injury, never operate this applicator without the guards supplied with the press or wire-processing machine in place. Reference the press or wire processing manufacturer's instruction manual.

CAUTION: Molex crimp specifications are valid only when used with Molex terminals, applicators and tooling.

Application Tooling Support

Phone: (402) 458-TOOL (8665)

E-Mail: toolingsupport@molex.com

Website: www.molex.com/applicationtooling

Molex is a registered trademark of Molex, LLC in the United States of America and may be registered in other countries; all other trademarks listed herein belong to their respective owners.