

DO NOT SCALE FROM THIS PRINT

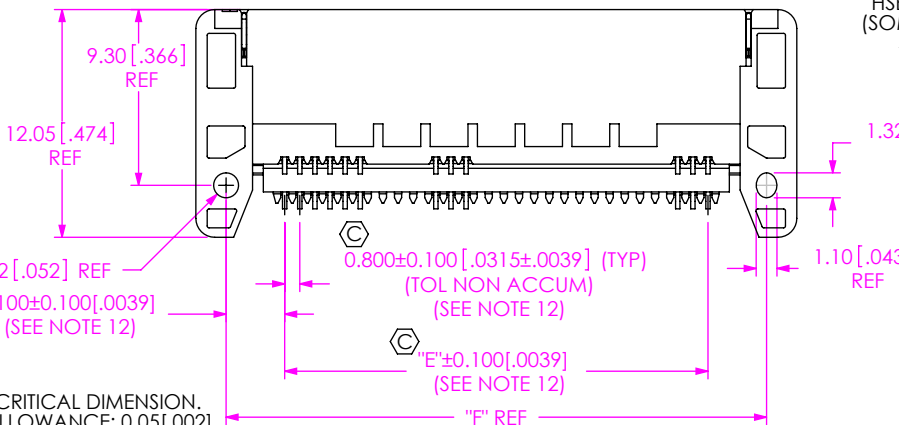
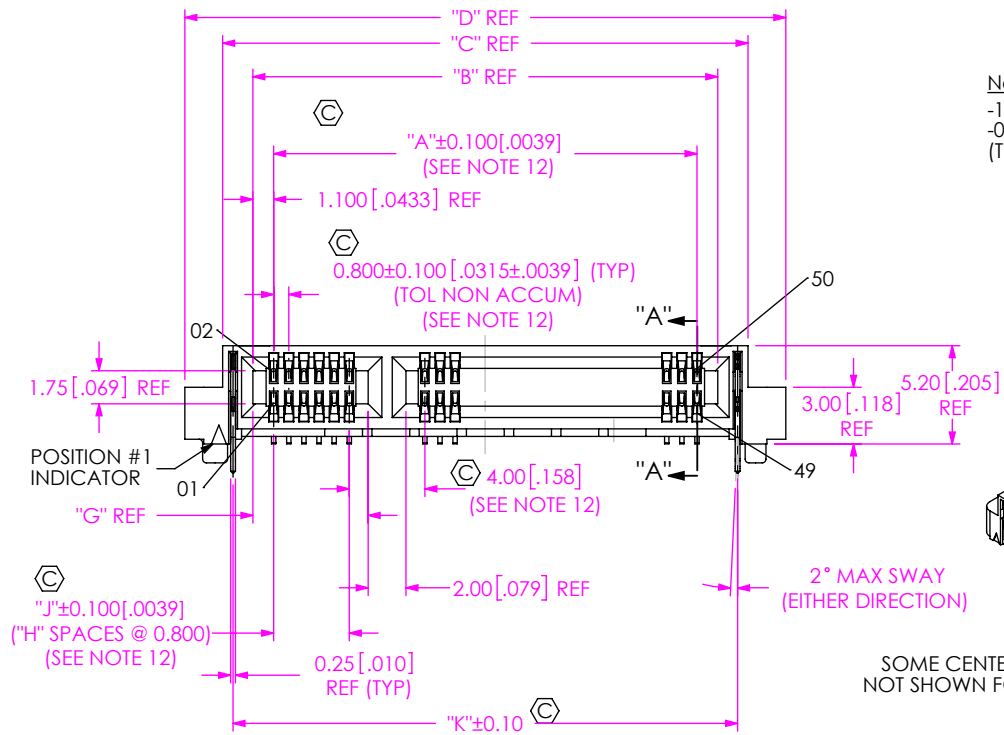

HSEC8-1XX-XX-X-RA-XX-XX

No OF POSITIONS
 -10, -20, -30 (ONE BANK OPTIONS)
 -09, -13, -25, -40, -49, -50, -60 (TWO BANK OPTIONS)

CARD THICKNESS
 -01: 1.57mm [.062] THICK CARD

PLATING SPECIFICATION
 -L: 10µ" SELECTIVE GOLD ON CONTACT AREA, TIN TAIL
 -S: 30µ" SELECTIVE GOLD ON CONTACT AREA, TIN TAIL

(* = NOT TOOLED)

PACKAGING (SEE NOTES 17 & 18)
 -BL: BOARD LOCK OPTION (USE HSEC8-XXX-01-RA-BL) (AVAILABLE IN -09, -13, -25, -40, -49, -50, -60 POS ONLY, SEE FIG 2, SHT 3)
 -L2: ECDP LATCHING OPTION (USE HSEC8-XXX-01-RA-L2) (AVAILABLE IN -09, -13, -25, -49 POS ONLY, SEE FIG 3, SHT 3)

OPTION
 -BL: BOARD LOCK OPTION (USE HSEC8-XXX-01-RA-BL) (AVAILABLE IN -09, -13, -25, -40, -49, -50, -60 POS ONLY, SEE FIG 2, SHT 3)
 -L2: ECDP LATCHING OPTION (USE HSEC8-XXX-01-RA-L2) (AVAILABLE IN -09, -13, -25, -49 POS ONLY, SEE FIG 3, SHT 3)

ROW SPECIFICATION
 -RA: RIGHT ANGLE (USE HSEC8-XXX-01-RA-XX)

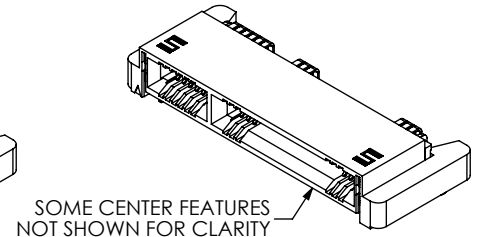
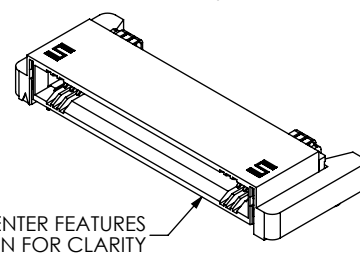

FIG 1
 HSEC8-125-01-X-RA SHOWN (SOME CENTER FEATURES NOT SHOWN FOR CLARITY)

TABLE 2

No OF POSITIONS	"A"	"B"	"C"	"D"	"E"	"F"	"G"	"H"	"J"	"K"
-10	7.200	9.400	12.600	16.60	7.200	13.40	NA	NA	NA	11.50
-20	15.200	17.400	20.600	24.60	15.200	21.40	NA	NA	NA	19.50
-30	23.200	25.400	28.600	32.60	23.200	29.40	NA	NA	NA	27.50
-09	9.600	11.800	15.000	19.00	9.600	15.80	4.500	3	2.400	13.90
-13	12.800	15.000	18.200	22.20	12.800	19.00	6.100	5	4.000	17.10
-25	22.400	24.600	27.800	31.80	22.400	28.60	6.100	5	4.000	26.70
-40	34.400	36.600	39.800	43.80	34.400	40.60	18.900	21	16.800	38.70
-49	41.600	43.800	47.000	51.00	41.600	47.80	22.900	26	20.800	45.90
-50	42.400	44.600	47.800	51.80	42.400	48.60	22.900	26	20.800	46.70
-60	50.400	52.600	55.800	59.80	50.400	56.60	22.900	31	24.800	54.70

- NOTES:
1. Ⓞ REPRESENTS A CRITICAL DIMENSION.
 2. MAXIMUM BURR ALLOWANCE: 0.05[.002].
 3. MINIMUM RETENTION FORCE: 2.22N [.500 LB] FOR PINS AND WELD TAB.
 4. MEASURE AT BEND TANGENCY.
 5. NOTE DELETED.
 6. NOTE DELETED.
 7. NOTE DELETED.
 8. DIMENSIONS MUST BE MEASURED ON 4 CONSECUTIVE PINS ON EACH END OF THE CONNECTOR.
 9. NOTE DELETED.
 10. NOTE DELETED.
 11. LTC-XX TO BE IN CLOSED POSITION AS SHOWN.
 12. MEASURE BOTH TOP AND BOTTOM ROWS.
 13. NOTE DELETED.
 14. SEE CO-AU-WI-3163-M DOCUMENT FOR CRITICAL MEASUREMENT SPECIAL INSTRUCTIONS (NOT NEEDED FOR OMM).
 15. SEE SUB-C-272-XX-X FOR PROCESS DESCRIPTION AND REQUIREMENTS.
 16. TRAY ARE STANDARD PACKAGING.
 17. ORDERS WILL BE PACKAGED ACCORDING TO THE SAMTEC PACKAGING EFFICIENCY STANDARDS (SPES) FOUND ON WWW.SAMTEC.COM
 18. ATTACH LABEL TO EACH REEL

UNLESS OTHERWISE SPECIFIED, DIMENSIONS ARE IN MILLIMETERS.
 TOLERANCES ARE:
 DECIMALS ANGLES
 X.X: ±0.3 [.01]
 X.XX: ±0.13 [.005]
 X.XXX: ±0.051 [.0020]

PROPRIETARY NOTE
 THIS DOCUMENT CONTAINS CONFIDENTIAL AND PROPRIETARY INFORMATION AND ALL DESIGN, MANUFACTURING, REPRODUCTION, USE, PATENT RIGHTS AND SALES RIGHTS ARE EXPRESSLY RESERVED BY SAMTEC, INC. THIS DOCUMENT SHALL NOT BE DISCLOSED, IN WHOLE OR PART, TO ANY UNAUTHORIZED PERSON OR ENTITY NOR REPRODUCED, TRANSFERRED OR INCORPORATED IN ANY OTHER PROJECT IN ANY MANNER WITHOUT THE EXPRESS WRITTEN CONSENT OF SAMTEC, INC.

MATERIAL: DO NOT SCALE DRAWING SHEET SCALE: 2.5:1
 INSULATOR: LCP UL94V-0, COLOR: BLACK
 CONTACT: BeCu
 WELD TAB: BRASS

samtec
 520 PARK EAST BLVD, NEW ALBANY, IN 47150
 PHONE: 812-944-6733 FAX: 812-948-5047
 e-Mail: info@SAMTEC.com code 53322

DESCRIPTION:
 0.8MM HIGH SPEED ASSEMBLY

DWG. NO.
HSEC8-1XX-XX-X-RA-XX-XX

BY: ROY LUO 11/05/2008 SHEET 1 OF 4

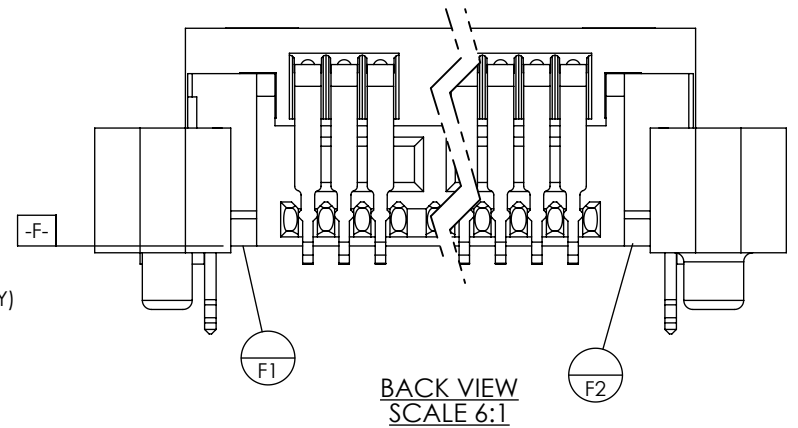
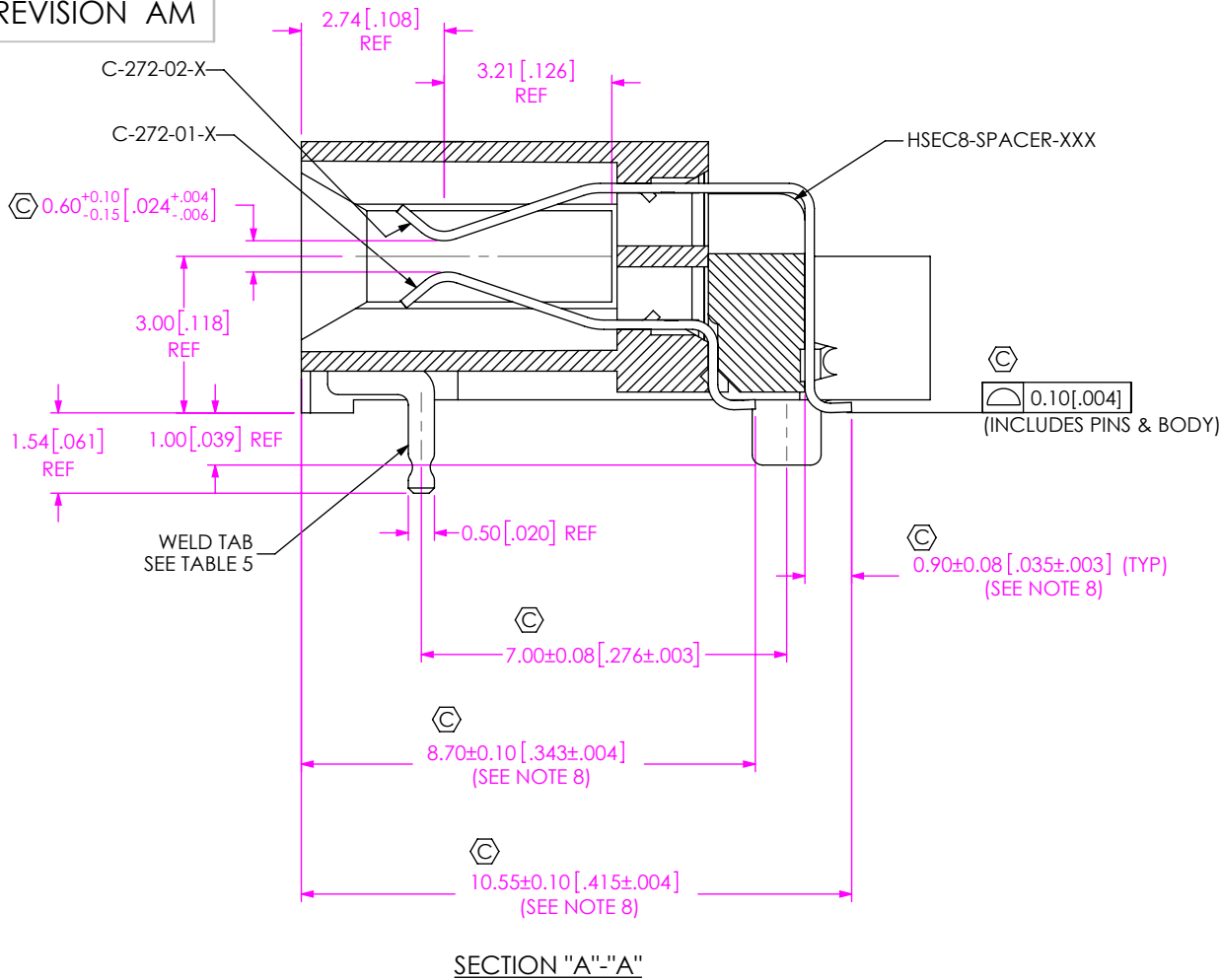

TABLE 5

OPTION	WT-51-XX-T
NO OPTION	WT-51-01-T
-BL	WT-51-01-T
-L2	WT-51-02-T

SECTION "A"-"A"

PROPRIETARY NOTE
 THIS DOCUMENT CONTAINS CONFIDENTIAL AND PROPRIETARY INFORMATION AND ALL DESIGN, MANUFACTURING, REPRODUCTION, USE, PATENT RIGHTS AND SALES RIGHTS ARE EXPRESSLY RESERVED BY SAMTEC, INC. THIS DOCUMENT SHALL NOT BE DISCLOSED, IN WHOLE OR PART, TO ANY UNAUTHORIZED PERSON OR ENTITY NOR REPRODUCED, TRANSFERRED OR INCORPORATED IN ANY OTHER PROJECT IN ANY MANNER WITHOUT THE EXPRESS WRITTEN CONSENT OF SAMTEC, INC.

DO NOT SCALE DRAWING

SHEET SCALE: 7:1



520 PARK EAST BLVD, NEW ALBANY, IN 47150
 PHONE: 812-944-6733 FAX: 812-948-5047
 e-Mail info@SAMTEC.com code 55322

DESCRIPTION:
 0.8MM HIGH SPEED ASSEMBLY

DWG. NO.
 HSEC8-1XX-XX-X-RA-XX-XX

BY: ROY LUO 11/05/2008 SHEET 2 OF 4

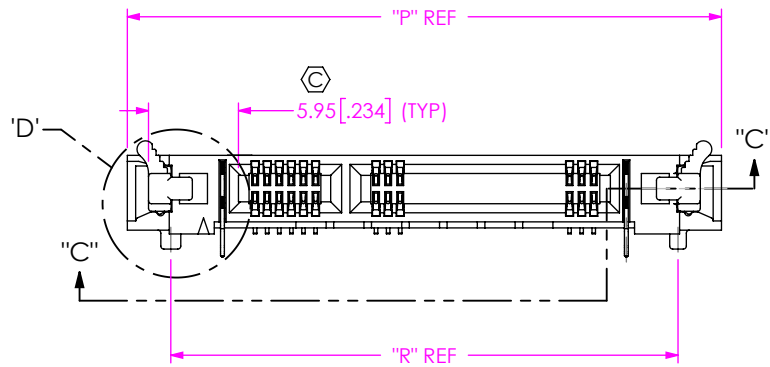
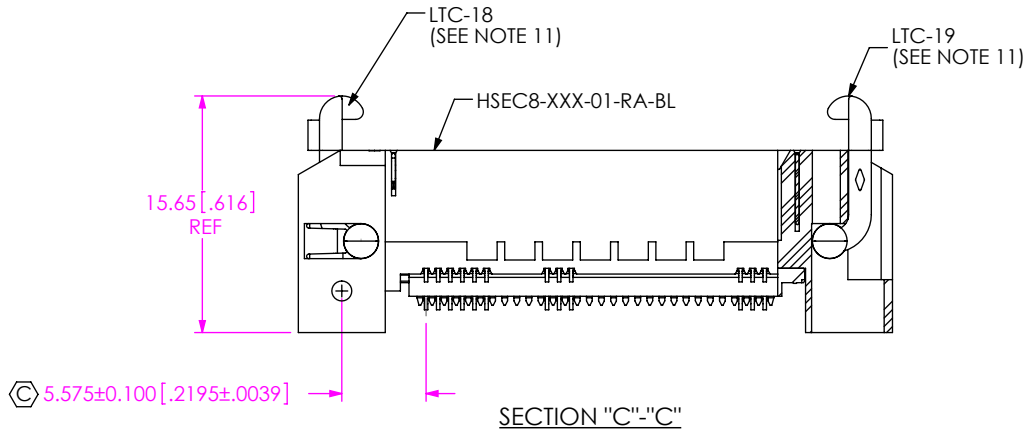
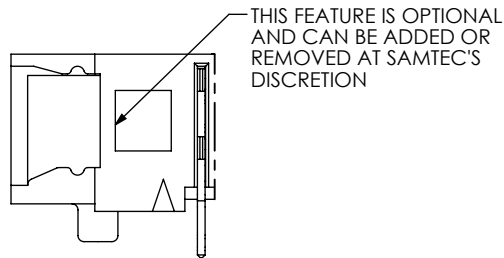

FIG 2
 -BL: BOARD LOCK OPTION ONLY AVAILABLE FOR -09, -13, -25, -40, -49, -50, -60 POSITIONS (SAME AS FIG 1, UNLESS OTHERWISE STATED) HSEC8-125-01-X-RA-BL SHOWN (SOME CENTER FEATURES NOT SHOWN FOR CLARITY)



DETAIL 'D'
 SCALE 4:1

LTC-XX REMOVED FOR CLARITY

No OF POSITIONS	"P"	"R"
-09	26.50	20.75
-13	29.70	23.95
*-20	32.10	26.35
-25	39.30	33.55
-40	51.30	45.55
-49	58.50	52.75
-50	59.30	53.55
-60	67.30	61.55

* = NOT TOOLED

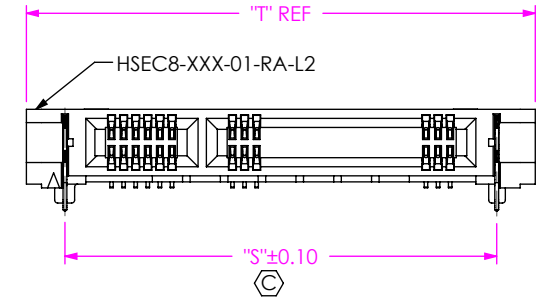
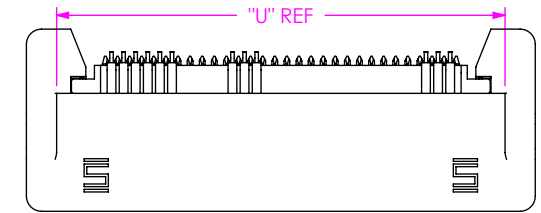

FIG 3
 -L2: ECDP LATCHING OPTION AVAILABLE ONLY IN -09, -13, -25 & -49 POSITIONS SAME AS FIG 1, UNLESS OTHERWISE STATED HSEC8-125-01-X-RA-L2 SHOWN

No OF POSITIONS	"S"	"T"	"U"
-09	15.76	20.86	16.86
-13	18.96	24.06	20.06
-25	28.56	33.66	29.66
-49	47.76	52.86	48.86

PROPRIETARY NOTE
 THIS DOCUMENT CONTAINS CONFIDENTIAL AND PROPRIETARY INFORMATION AND ALL DESIGN, MANUFACTURING, REPRODUCTION, USE, PATENT RIGHTS AND SALES RIGHTS ARE EXPRESSLY RESERVED BY SAMTEC, INC. THIS DOCUMENT SHALL NOT BE DISCLOSED, IN WHOLE OR PART, TO ANY UNAUTHORIZED PERSON OR ENTITY NOR REPRODUCED, TRANSFERRED OR INCORPORATED IN ANY OTHER PROJECT IN ANY MANNER WITHOUT THE EXPRESS WRITTEN CONSENT OF SAMTEC, INC.

DO NOT SCALE DRAWING

SHEET SCALE: 2:1

samtec

520 PARK EAST BLVD, NEW ALBANY, IN 47150
 PHONE: 812-944-6733 FAX: 812-948-5047
 e-Mail info@SAMTEC.com code 55322

DESCRIPTION:
 0.8MM HIGH SPEED ASSEMBLY

DWG. NO.
HSEC8-1XX-XX-X-RA-XX-XX

BY: ROY LUO 11/05/2008 SHEET 3 OF 4

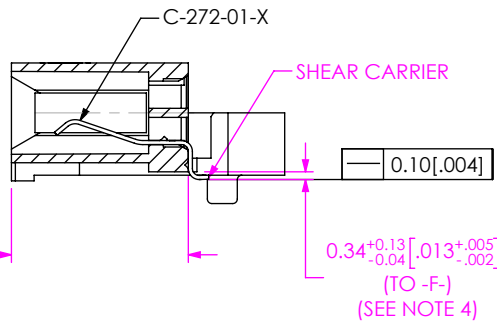

IN-PROCESS VIEW 1
FILL FIRST ROW

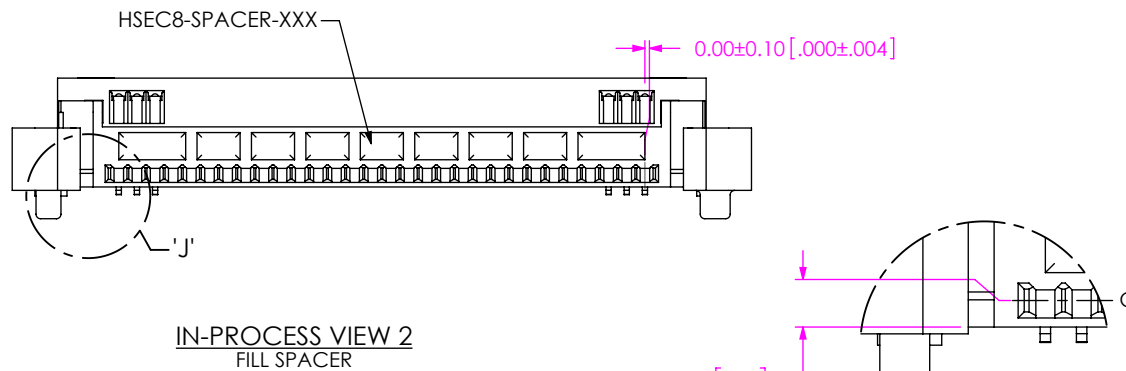

IN-PROCESS VIEW 2
FILL SPACER

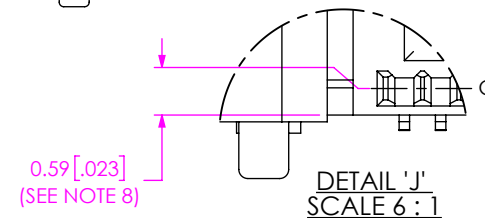

DETAIL 'J'
SCALE 6:1

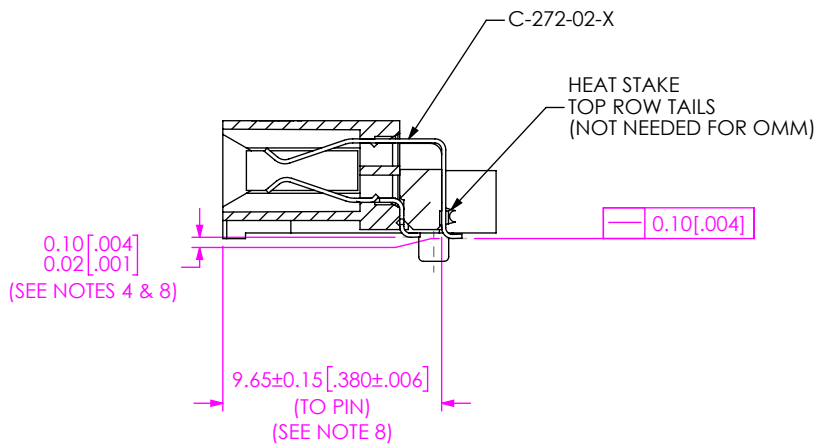

IN-PROCESS VIEW 3
FILL SECOND ROW

PROPRIETARY NOTE
 * THIS DOCUMENT CONTAINS CONFIDENTIAL AND PROPRIETARY INFORMATION AND ALL DESIGN, MANUFACTURING, REPRODUCTION, USE, PATENT RIGHTS AND SALES RIGHTS ARE EXPRESSLY RESERVED BY SAMTEC, INC. THIS DOCUMENT SHALL NOT BE DISCLOSED, IN WHOLE OR PART, TO ANY UNAUTHORIZED PERSON OR ENTITY NOR REPRODUCED, TRANSFERRED OR INCORPORATED IN ANY OTHER PROJECT IN ANY MANNER WITHOUT THE EXPRESS WRITTEN CONSENT OF SAMTEC, INC. *

DO NOT SCALE DRAWING

SHEET SCALE: 3:1



520 PARK EAST BLVD, NEW ALBANY, IN 47150
 PHONE: 812-944-6733 FAX: 812-948-5047
 e-Mail info@SAMTEC.com code 55322

DESCRIPTION:
 0.8MM HIGH SPEED ASSEMBLY

DWG. NO.
 HSEC8-1XX-XX-X-RA-XX-XX

BY: ROY LUO 11/05/2008 SHEET 4 OF 4