

RECOMMENDED SOLDER PAD DESIGN

PART NUMBER W/CAP IN TUBE	CKT. SIZE	DIM. A	DIM. B
87340-04*5	4	4.00	2.00
87340-06*5	6	6.00	4.00
87340-08*5	8	8.00	6.00
87340-10*5	10	10.00	8.00
87340-12*5	12	12.00	10.00
87340-14*5	14	14.00	12.00
87340-16*5	16	16.00	14.00
87340-18*5	18	18.00	16.00
87340-20*5	20	20.00	18.00

PART NO. LEGEND  
 87340- \* \* \* \*  
 ———— PACKAGING  
 5 - TUBE  
 6 - T&R  
 ———— PLATING SEE NOTE 3  
 ———— CIRCUIT SIZE

NOTES:

- FOR ILLUSTRATION PURPOSES, DRAWING SHOWS PART WITH 12 CIRCUIT SIZE.
- MATERIAL:  
HOUSING: LCP GLASS FILLED, UL 94V-0  
SUITABLE FOR SURFACE-MOUNT SOLDERING PROCESS.  
COLOR BLACK  
TERMINAL: PHOSPHOR BRONZE ALLOY.
3. PLATING- 9 : 0.38µm MINIMUM GOLD PLATE AT CONTACT AREA, AND 1.90µm MINIMUM TIN PLATE AT P.C TAIL AREA, BOTH OVER 1.27µm MINIMUM NICKEL OVERALL.  
3 : 0.05-0.25µm GOLD PLATE AT CONTACT AREA, AND 1.90µm MINIMUM TIN PLATE AT P.C TAIL AREA, BOTH OVER 1.27µm MINIMUM NICKEL OVERALL.
4. COPLANARITY OF P.C TAIL TO BE MEASURED BY RESTING THE PART ON A FLAT GAGE SURFACE.
5. THIS AREA OF PART TO BE HEAT-STAKED TO RETAIN CONTACTS.
6. POSITION OF CAP TO BE LOCATED AT CENTER OF DIMENSION "A" REGARDLESS OF CIRCUIT SIZE.
7. PRODUCT SPECIFICATION PS-87340 APPLIES.
8. PART TO BE PACKAGED IN TAPE-&-REEL. SEE SHEET 2 FOR PACKAGING DETAILS.
9. CONTACT FACTORY FOR PARTS AVAILABILITY.

SYMBOLS	THIS DRAWING CONTAINS INFORMATION THAT IS PROPRIETARY TO MOLEX ELECTRONIC TECHNOLOGIES, LLC AND SHOULD NOT BE USED WITHOUT WRITTEN PERMISSION		CURRENT REV DESC:		<b>molex</b>
	DIMENSION UNITS	SCALE			
▽ = 0	mm	NTS			MGRID, VLPR II TOP ENTRY RECEPT., SMT W/CAP FOR PICK-&-PLACE
▽ = 0	GENERAL TOLERANCES (UNLESS SPECIFIED)				
▽ = 0		MM	INCH		
▽ = 0	4 PLACES ±			EC NO: 740811	PRODUCT CUSTOMER DRAWING
▽ = 0	3 PLACES ±			DRWN: DANUSA 2023/02/13	
▽ = 0	2 PLACES ±	0.2		CHK'D: SUAIFR 2023/03/02	DOCUMENT NUMBER <b>SD-87340-XX92</b>
▽ = 0	1 PLACE ±			APPR: MRAMAKRISHNA 2023/03/03	
▽ = 0	0 PLACES ±			INITIAL REVISION:	DOC TYPE PSD
▽ = 0	ANGULAR TOL ±	3.0°		DRWN: JWAN 1995/01/25	DOC PART 001
▽ = 0	DRAFT WHERE APPLICABLE MUST REMAIN WITHIN DIMENSIONS		THIRD ANGLE PROJECTION	DRAWING A3-SIZE	REVISION D5
▽ = 0				SERIES 87340	SHEET NUMBER 1 OF 2
				MATERIAL NUMBER SEE TABLE	CUSTOMER GENERAL MARKET

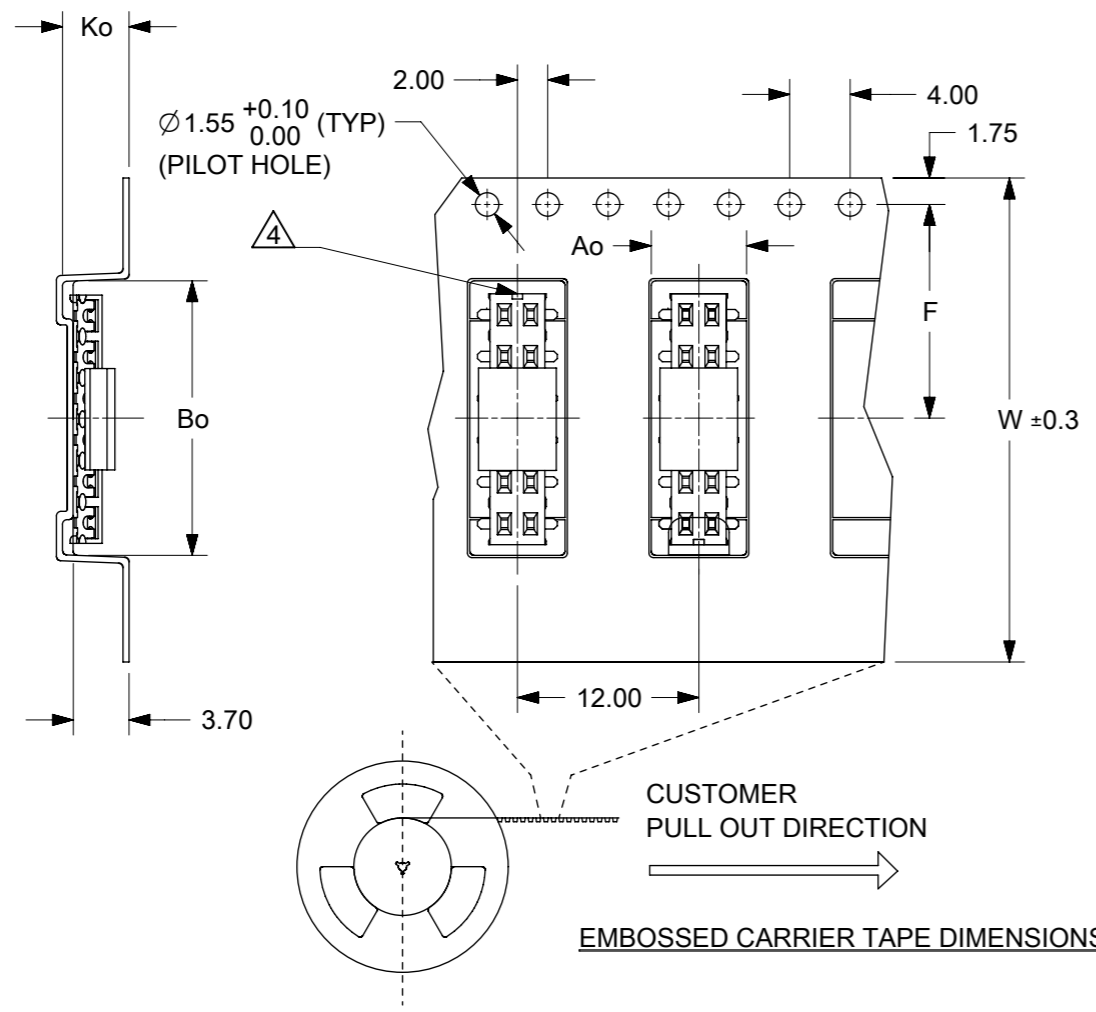

PART NO. W/CAP IN TAPE/REEL	CKT. SIZE	Ao	Bo	F	W	Ko
87340-04*6	4	6.70	5.30	11.50	24.00	5.30
87340-06*6	6	6.50	6.50	7.50	16.00	4.50
87340-08*6	8	6.70	8.40	11.50	24.00	5.30
87340-10*6	10	6.70	10.40	11.50	24.00	5.30
87340-12*6	12	6.60	12.40	11.50	24.00	4.40
87340-14*6	14	6.60	14.30	11.50	24.00	4.40
87340-16*6	16	6.60	16.30	11.50	24.00	4.40
87340-20*6	20	6.70	6.70	20.20	44.00	5.30

PART LEGEND NA FOR BELOW TABLE

PART NO. W/CAP IN TAPE/REEL	CKT. SIZE	Ao	Bo	F	W	Ko
87340-1196	10	6.70	10.40	11.50	24.00	5.30

NOTE: CKT 7 AND 8 UN-FILLED. REFER HOUSING DRAWING

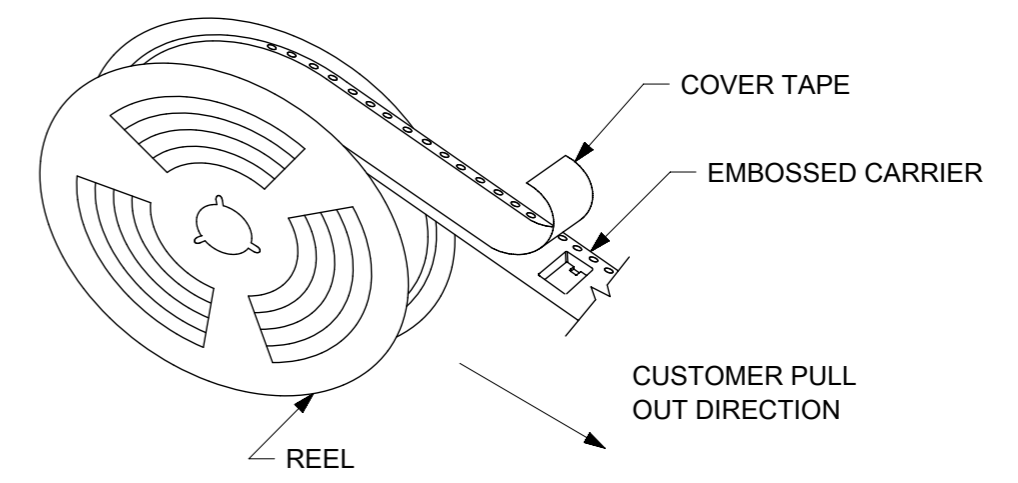

TAPE AND REEL ASSEMBLY SHOWN IS FOR ILLUSTRATION ONLY.

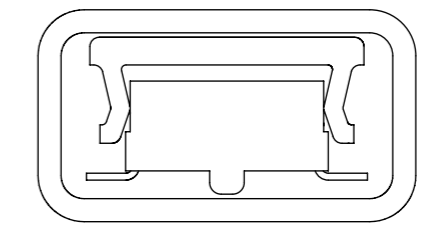

PART IN TUBE VIEW

NOTES:

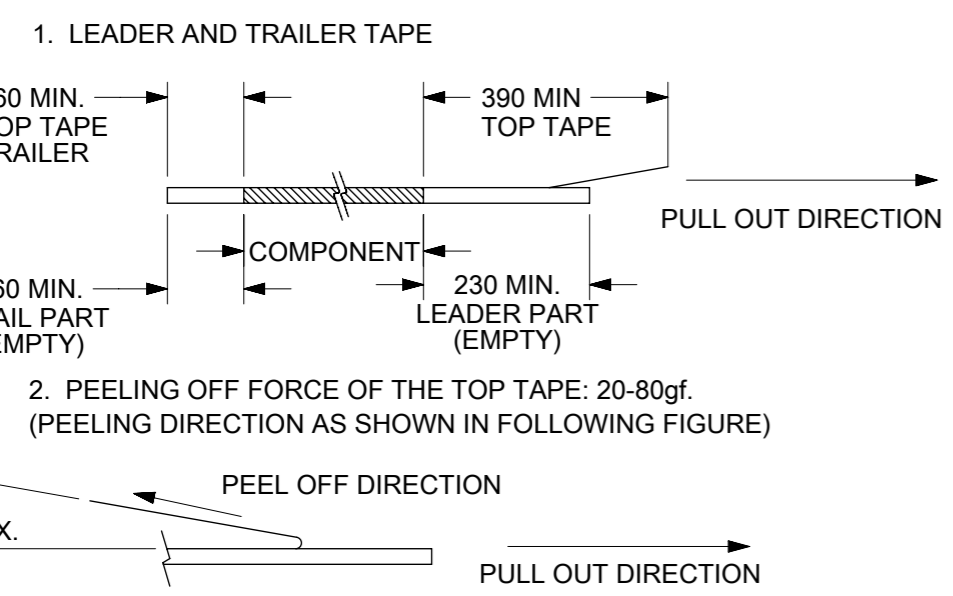

- 3. PACKAGING STANDARD IS AS PER EIA-481.
- 4. TAPE & REEL QUANTITY = 1000 PCS/REEL
- 5. NO FIX ORIENTATION OF ASSEMBLY PART IN T&R.

SYMBOLS	THIS DRAWING CONTAINS INFORMATION THAT IS PROPRIETARY TO MOLEX ELECTRONIC TECHNOLOGIES, LLC AND SHOULD NOT BE USED WITHOUT WRITTEN PERMISSION		CURRENT REV DESC:		
	DIMENSION UNITS	SCALE			
▽ = 0	mm	NTS			PRODUCT CUSTOMER DRAWING
▽ = 0	GENERAL TOLERANCES (UNLESS SPECIFIED)				
▽ = 0		MM	INCH		
▽ = 0	4 PLACES ±			EC NO: 740811	DOCUMENT NUMBER
▽ = 0	3 PLACES ±			DRWN: DANUSA 2023/02/13	
▽ = 0	2 PLACES ± 0.2			CHK'D: SUAIFR 2023/03/02	DOC TYPE
▽ = 0	1 PLACE ±			APPR: MRAMAKRISHNA 2023/03/03	DOC PART
▽ = 0	0 PLACES ±			INITIAL REVISION:	REVISION
▽ = 0	ANGULAR TOL ± 3.0°			DRWN: JWAN 1995/01/25	
▽ = 0	DRAFT WHERE APPLICABLE MUST REMAIN WITHIN DIMENSIONS			APPR: RWONG 1995/01/25	
▽ = 0		THIRD ANGLE PROJECTION	DRAWING	SERIES	MATERIAL NUMBER
▽ = 0			A3-SIZE	87340	CUSTOMER
					SEE TABLE
					GENERAL MARKET
					SHEET NUMBER
					2 OF 2