



IEEE 802.3af POWER INTERFACE SWITCH FOR POWER OVER ETHERNET (PoE) POWERED DEVICES

FEATURES

- Integrated Power Interface Switch for IEEE 802.3af Powered Devices (PDs)
- Provides PD Detection Signature
- Provides PD Classification Signature (Class 0–4)
- Programmable Inrush Current Limit
- Internal 0.3-Ω Low-Side FET
- Interfaces to DC/DC Soft-Start for DC/DC Enable
- Internal Thermal Protection – Disconnects PD Load
- Minimal External Parts Count
- 8-Pin SOIC, 8-Pin TSSOP Packages

APPLICATIONS

- VoIP Phones
- Internet Appliances
- Wireless LAN Access Points
- Bluetooth™ Access Points

DESCRIPTION

Acting as an interface between the power sourcing equipment (PSE) and the powered device (PD), the TPS2370 performs all detection, classification, inrush current limiting, and switch FET control that is necessary for compliance with the IEEE 802.3af Standard. An internal 0.3-Ω FET provides maximum power delivery. As an additional feature, the TPS2370 interfaces with the enable/soft-start signal of a dc-to-dc converter, eliminating the need to have an accurate UVLO in the dc-to-dc converter.

At low input voltages (1.8 V to 10 V), the TPS2370 draws less than 12 μA, allowing accurate sensing of the external 24.9-kΩ discovery resistor. At input voltages between 15 V and 20 V, an external resistor sets the level of current to be drawn during classification mode. TPS2370 is compatible with current as well as voltage measurement schemes for classification. Above 20-V input, the classification current is shut off, reducing internal power dissipation.

The TPS2370 drives an internal low-side FET for control of the return side of the power path. The internal FET is turned on when the input voltage reaches 40 V and above. When the input voltage decreases, the FET remains on until the input voltage drops to below 30 V.

TYPICAL APPLICATION

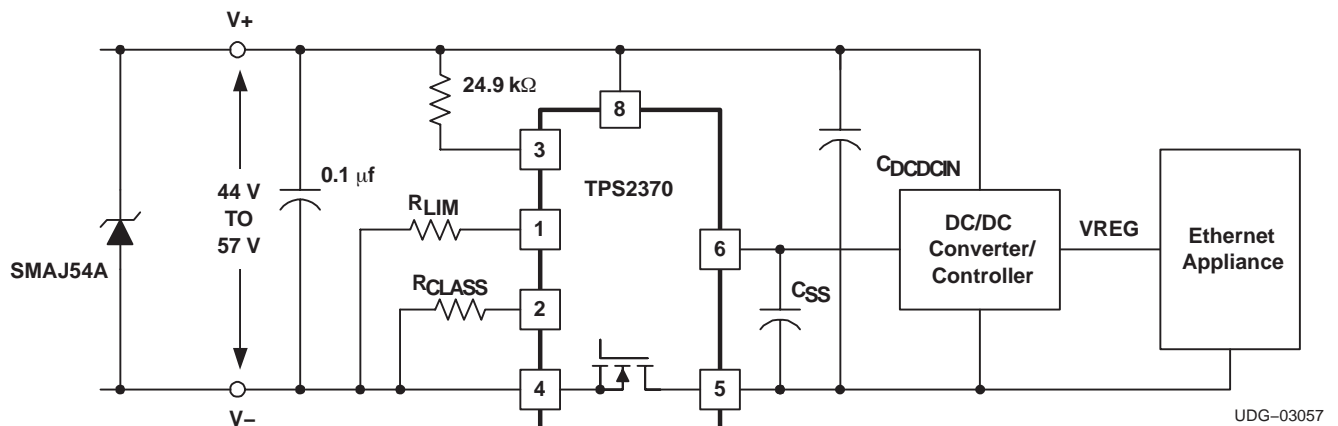

Please be aware that an important notice concerning availability, standard warranty, and use in critical applications of Texas Instruments semiconductor products and disclaimers thereto appears at the end of this data sheet.

PowerPAD™ is a trademark of Texas Instruments. Bluetooth™ is a trademark of Bluetooth SIG, Inc.

DESCRIPTION (CONTINUED)

During initial turnon of the switch (inrush mode), an external resistor is used to program the inrush current, allowing a wide range of capacitor values to be used at the load. According to IEEE 802.3af specification, inrush current of 400 mA is allowed only for 50 ms, limiting the load capacitor to approximately 180 μ F. A programmable inrush current limit removes this limitation, allowing a larger capacitor to be used with a lower inrush current limit.



These devices have limited built-in ESD protection. The leads should be shorted together or the device placed in conductive foam during storage or handling to prevent electrostatic damage to the MOS gates.

ORDERING INFORMATION

T _A	PACKAGE ⁽¹⁾	PART NUMBER
0°C to 70°C	Plastic TSSOP (PW)	TPS2370PW
	Plastic SOIC (D)	TPS2370D

(1) The PW and D packages are also available taped and reeled. Add an R suffix to the device type (i.e., TPS2370PWR).

ABSOLUTE MAXIMUM RATINGS

Over operating free-air temperature range unless otherwise noted ⁽²⁾

	TPS2370	UNIT
Input voltage range, wrt V _{EE}	ILIM	4
	CLASS	12
	DET, RTN, EN_DC, VDD	68
	EN_DC (wrt RTN)	5
Operating junction temperature range, T _J	-55 to 150	°C
Storage temperature, T _{stg}	-65 to 150	°C
Lead temperature 1,6 mm (1/16 inch) from case for 10 seconds	300	°C

(2) Stresses beyond those listed under “absolute maximum ratings” may cause permanent damage to the device. These are stress ratings only, and functional operation of the device at these or any other conditions beyond those indicated under “recommended operating conditions” is not implied. Exposure to absolute-maximum-rated conditions for extended periods may affect device reliability.

RECOMMENDED OPERATING CONDITIONS

	MIN	NOM	MAX	UNIT
Input voltage, V _I		48	57	V
Operating junction temperature, T _J	0		70	°C

DISSIPATION RATINGS⁽³⁾⁽⁴⁾

PACKAGE	THERMAL IMPEDANCE JUNCTION-TO-AMBIENT	T _A < 25°C POWER RATING	T _A = 25°C DERATING FACTOR	T _A = 70°C POWER RATING
8-Pin Plastic TSSOP (PW)	258.5°C/W	464 mW	3.9 mW/°C	290 mW
8-Pin Plastic SOIC (D)	176.0°C/W	682 mW	5.7 mW/°C	426 mW

(3) Test board conditions:

1. 3" x 3", 4 layers, thickness: 0.062"
2. 1.5 oz. copper traces located on the top of the PCB
3. 1.5 oz. copper ground plane on the bottom of the PCB
4. 0.5 oz. copper ground planes on the 2 internal layers
5. 12 thermal vias

(4) Maximum power dissipation may be limited by overcurrent protection.

ELECTRICAL CHARACTERISTICS

V_{DD} = 48 V; T_A = 0°C to 70°C; all voltages and currents are with respect to V_{EE}; (unless otherwise noted)

PARAMETER	TEST CONDITIONS	MIN	TYP	MAX	UNIT
SUPPLY					
Offset current	V _{DD} = 1.8 V, DET = OPEN			3	μA
I _{DD} Sleep current	1.8 V ≤ V _{DD} < 10 V, DET = OPEN		5	12	
I _{DET} Detection load current	R _{DET} = 24.9 kΩ, V _{DD} = 1.8 V	70	73	76	
	R _{DET} = 24.9 kΩ, V _{DD} = 9.5 V	380	390	400	
Classification current threshold	Turn on	10.0	12.5	14.0	V
	Turn off	21.5	22.5	23.5	
V _{DD} current class 0	0.44 W ≤ P _{PoE} ≤ 12.95 W, 15 V ≤ V _{DD} ≤ 20 V, R _{CLASS} = 4.42 kΩ	2.2	2.5	2.8	mA
V _{DD} current class 1	0.44 W ≤ P _{PoE} ≤ 3.84 W, 15 V ≤ V _{DD} ≤ 20 V, R _{CLASS} = 953 Ω	10.4	10.8	11.5	
V _{DD} current class 2	3.84 W ≤ P _{PoE} ≤ 6.49 W, 15 V ≤ V _{DD} ≤ 20 V, R _{CLASS} = 549 Ω	18.1	18.6	19.5	
V _{DD} current class 3	6.49 W ≤ P _{PoE} ≤ 12.95 W, 15 V ≤ V _{DD} ≤ 20 V, R _{CLASS} = 357 Ω	27.7	28.4	29.9	
V _{DD} current class 4	Reserved for future use, 15 V ≤ V _{DD} ≤ 20 V, R _{CLASS} = 255 Ω	38.5	39.6	42.0	
V _{DD} quiescent current	30 V ≤ V _{DD} ≤ 57 V, R _{CLASS} = 255 Ω		500	800	μA
Input UVLO threshold	Turn on	38.6	40.2	41.8	V
	Turn off	30.2	31.4	32.6	
UVLO hysteresis		7.8	8.8	9.8	
EN_DC sink current		40	80	200	μA
RTN threshold for EN_DC		1.2	1.5	1.8	V
DMOS R _{DS(on)}	I _{RTN} = 200 mA	0.15	0.30	0.60	Ω
Full load current limit	V _{RTN} < 1.5 V	405	455	505	mA
ILIM current limit programming	R _{LIM} = 125 kΩ, V _{RTN} > 1.5 V during startup	180	250	300	
Thermal shutdown temperature			144		°C
Thermal shutdown hysteresis			20		

**D OR PW PACKAGE
(TOP VIEW)**

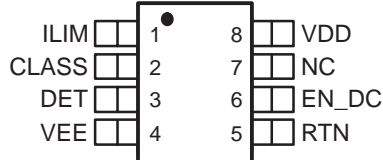

TERMINAL FUNCTIONS

TERMINAL NAME	NO.	I/O	DESCRIPTION
CLASS	2	O	Sets classification level with a single resistor to VEE. A precision voltage of 10 V is applied to this pin during classification. R _{CLASS} values listed in Table 1.
DET	3	O	Connect the 24.9-kΩ detection resistor (R _{DET}) between this pin and VDD.
EN_DC	6	O	Ties to dc-to-dc converter's shutdown or soft-start pin. Sinks 80 μA until the load capacitor is fully charged.
ILIM	1	O	Sets start-up current limit level with a resistor to VEE. If using C _{DC2DCIN} > 180 μF, I _{RUSH} must be less than 400 mA. Extra capacitance on ILIM pin can cause oscillations in the current waveform.
RTN	5	O	Return pin. Connect this pin to input return side of the dc-to-dc converter.
VDD	8	I	Connection to PD input port positive voltage.
VEE	4	I	Input side power return for the controller.

$$(1) I_{\text{INRUSH}} = 450 \text{ mA} - \left(\frac{25 \text{ k}\Omega}{R_{\text{LIM}}} \right) \times (1 \text{ A})$$

DETAILED PIN DESCRIPTIONS**ILIM (Pin 1)**

Inrush current limiting pin. This pin is used to program the inrush current of the device. By placing a resistor to VEE from this pin, the inrush current into the load is limited via the following equation:

$$I_{\text{INRUSH}} = 450 \text{ mA} - \left(\frac{25 \text{ k}\Omega}{R_{\text{LIM}}} \right) \times (1 \text{ A}) \quad (1)$$

CLASS (Pin 2)

Classification pin. The PD can be optionally classified by adding a resistor from this pin to ground. The resistor specific to each class is given in *Table 1: PoE Classification Resistance Values*.

DET (Pin3)

Detection pin. This pin is used to set up the detection resistance during PD detection. By tying a resistor, R_{DET}, from this pin to VDD, the user sets the detection resistance. It should be noted that the device itself looks like approximately 1 MΩ of resistance in parallel with R_{DET}.

VEE (Pin 4)

Negative supply to the device.

RET (Pin 5)

Negative supply to the load. This pin is the drain side of a FET between the RET pin and the VEE pin, providing hot swap capabilities to the load. When the FET is switched on, there is approximately 300 mΩ between this pin and VEE.

EN_DC (Pin 6)

Enable pin for the load. This pin is intended to be used with a dc-to-dc converter with a soft start capacitor. When power is not available to the dc-to-dc converter, this pin sinks 80 μA and holds off the soft-start capacitor on the dc-to-dc converter. Once the voltage across the load is within 1.5 V of its final value, the EN_DC pin stops drawing current and becomes high impedance, allowing the dc-to-dc converter to soft start normally.

VDD (Pin 8)

Positive supply to the device.

STATE DIAGRAM

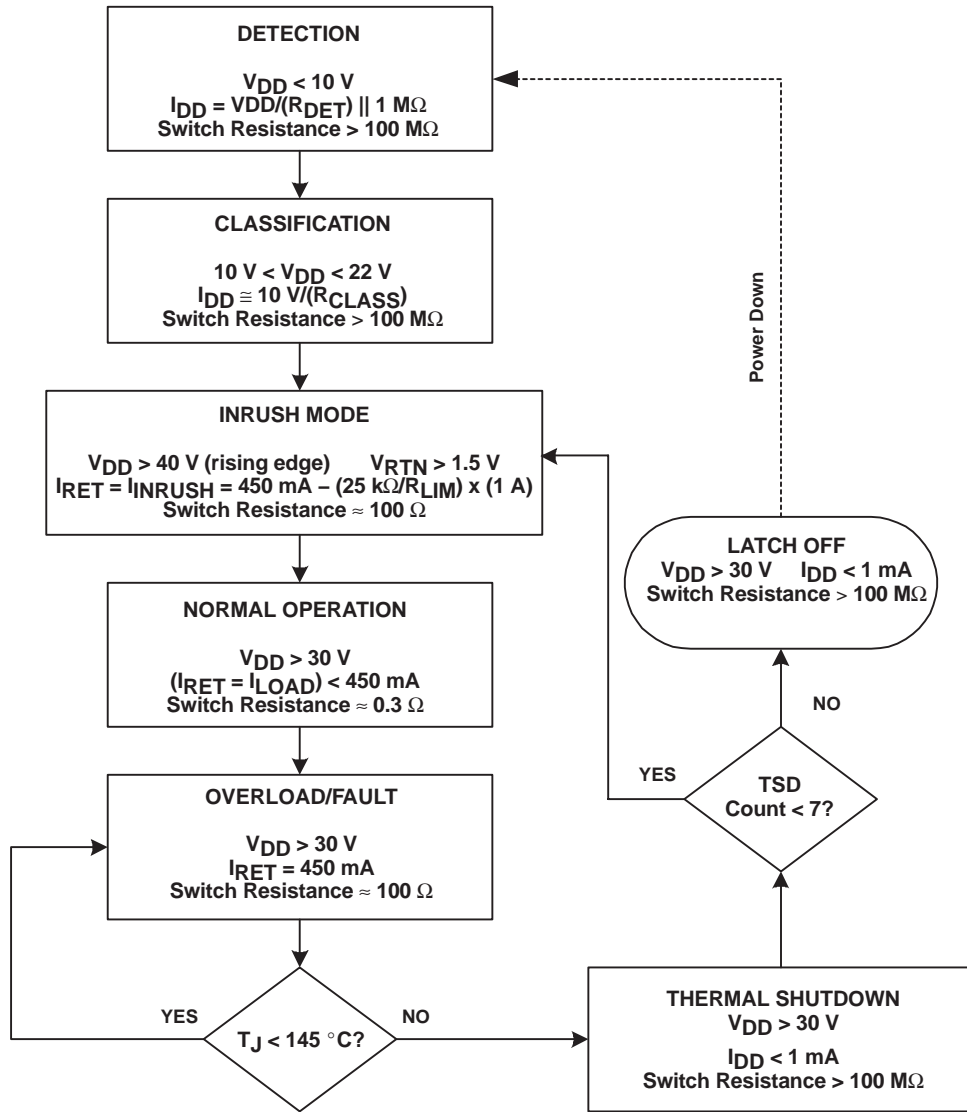

MACHINE STATE

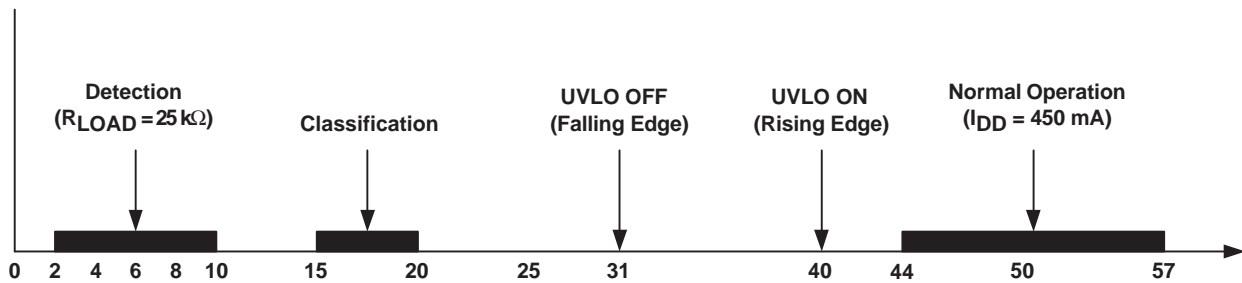

APPLICATION INFORMATION

OVERVIEW

With the addition of power via media-dependent interface (MDI) to the IEEE 802.3af Standard, all data terminal equipment (DTE) now has the option to receive power over existing cabling that is used for data transmission. The IEEE 802.3af Standard defines the requirements associated with providing and receiving power over the existing cabling. The power sourcing equipment (PSE) provides the power on the cable and the powered device (PD) receives the power. As part of the IEEE 802.3af Standard, the interface between the PSE and PD is defined as it relates to the detection and classification protocol.

POWER SOURCING EQUIPMENT DETECTION OF A POWERED DEVICE

A powered device (PD) draws power or requests power by participating in a PD detection algorithm. This algorithm requires the power sourcing equipment (PSE) to probe the link looking for a valid PD. The PSE probes the link by sending out a voltage between 2.8 V and 10 V across the power lines. A valid PD detects this voltage and places a resistance of between 23.75 k Ω and 26.25 k Ω across the power lines. Naturally, the current varies depending on the input voltage. On detecting this current, the PSE concludes that a valid PD is connected at the end of the ethernet cable and is requesting power.

If the powered device (PD) is in a state in which it does not accept power, the PD is required to place a resistance above or below the values listed for a valid PD. On the lower end, a range between 12 k Ω and 23.75 k Ω signifies that the PD does not require power. On the higher end, the range is defined to be between 26.25 k Ω and 45 k Ω . Any resistance value less than 12 k Ω and greater than 45 k Ω , is interpreted by the PSE as a nonvalid PD detection signature.

The TPS2370 participates in the detection algorithm by activating an internal FET, which connects the DET pin of the device to VEE. As a result, any resistance connected between VDD and the DET pin of the TPS2370 is, in effect, across the power lines. This internal FET is active only when input power to the PD is between 2.8 V and 10 V.

POWER SOURCING EQUIPMENT CLASSIFICATION OF A POWERED DEVICE

After the detection phase, the PSE can optionally initiate a classification of the PD. The classification of a PD is used by the PSE to determine the maximum power required by the PD during normal operation. Five different levels of classification are defined by the IEEE 802.3af Standard. These levels are shown in Table 2.

Table 2. Powered Device Classification Levels

CLASS	USAGE	POWER DEVICE POWER (W)		CLASSIFICATION CURRENT (mA)	
		MIN	MAX	MIN	MAX
0	Default	0.44	12.95	0	4
1	Optional	0.44	3.84	9	12
2	Optional	3.84	6.49	17	20
3	Optional	6.49	12.95	26	30
4	Not allowed	reserved for future use		36	44

Classification of the PD is optionally performed by the PSE only after a valid PD has been detected. To determine PD classification, the PSE increases the voltage across the power lines to between 15.5 V and 20.5 V. The amount of current drawn by the PD determines the classification (see Table 2).

When the input voltage to the TPS2370 is between 14.0 V and 20.5 V, the TPS2370 uses an internal regulator to generate a fixed voltage on the CLASS pin. A resistor connected between the CLASS pin and VEE draws a fixed amount of current and thereby defines the classification level of the PD.

APPLICATION INFORMATION

POWER SOURCING EQUIPMENT POWER TO THE POWERED DEVICE

On completion of the detection and optional classification phases, the PSE ramps its output voltage above 42 V. Once the UVLO threshold has been reached, the internal FET is turned on. At this point, the PD begins to operate normally and it continues to operate normally as long as the input voltage remains above 30 V. For most PDs, this input voltage is down-converted using an onboard dc-to-dc converter to generate the required voltages.

The TPS2370 is designed to apply the PSE output voltage of 36 V to 57 V across the input of the onboard dc-to-dc converter. This is accomplished on the TPS2370 by turning on an internal pass FET located across the power return.

PROGRAMMING THE INRUSH CURRENT

During the initial turnon of the pass FET, an inrush current is created from the charging of the capacitance at the input of the dc-to-dc converter. According to the IEEE 802.3af specification, if the input capacitance is less than 180 μ F, the PSE limits the inrush current. If the input capacitance is greater than 180 μ F, the IEEE 802.3af specification requires the PD to limit the inrush current to less than 400 mA.

In order to satisfy the IEEE 802.3af requirements, the TPS2370 has been designed for a typical current limit of 450 mA. This current limit setting satisfies the normal operation requirements as well as the inrush requirements for a capacitive load of 180 μ F or less. If a larger load capacitor is desired, the TPS2370 has been designed with a programmable inrush current limit feature. This feature allows the designer the option of using a capacitor larger than 180 μ F. Note that the inrush current feature may also be used to lower voltage drops in the cabling between the PSE and the PD during start-up.

The programmable inrush current limit has a range of 50 mA to 449 mA. The limit is set by connecting an external resistor from ILIM (pin 1) to VEE (pin 4) of the TPS2370. Equation (1) shows the calculation for the programmable inrush current limit.

$$I_{\text{INRUSH}} = 450 \text{ mA} - \left(\frac{25 \text{ k}\Omega}{R_{\text{LIM}}} \right) \times (1 \text{ A}) \quad (2)$$

where R_{LIM} is a value between 63.5 k Ω and 25 M Ω .

USING EN_DC AS A SOFT-START OR A POWER-GOOD FUNCTION

The EN_DC pin is an output intended for use as a soft-start for a dc-to-dc converter. During the initial turnon of the pass FET, an internal 80- μ A current sink is enabled on the EN_DC pin. This internal current sink is removed only after the load capacitance has been charged to within 1.5-V of the supply voltage. By connecting the EN_DC output to the soft-start capacitor of a dc-to-dc converter, the internal current sink keeps the dc-to-dc converter off during start-up. Once the voltage across the converter has reached within 1.5 V of full voltage, the dc-to-dc converter is allowed to soft start.

For operation as a power-good output, the EN_DC requires an external pull-up resistor. A 1-M Ω resistor is recommended. The EN_DC output also requires a clamp to limit the output voltage to within recommended operating levels. A 5-V zener diode connected between EN_DC and RTN (pin 5 of the TPS2370) is recommended. This configuration allows the EN_DC pin to act as an open-drain output with which many designers are more familiar.

APPLICATION INFORMATION

SURGE SUPPRESSION

As specified in the *Absolute Maximum Ratings* table, the absolute maximum input voltage of the TPS2370 is 68 V. The IEEE 802.3af Power-over-Ethernet Standard specifies the voltage range of PSE output as between 44 V and 57 V. This PSE output voltage range would be reduced by cable, connector, and other IR drops between the PSE and the TPS2370 in the PD. However, the use of extended cable lengths and transformers in some applications may induce transients in excess of 68 V during a hot plug event. To manage these transient events and keep them from significantly exceeding the application's maximum voltage, a transorb such as the SMAJ54A should be placed between the positive input supply, VDD (pin 8), and the negative input supply, VEE (pin 4). This, combined with a 0.1- μ F bypass capacitor in parallel with the transorb, helps to protect the TPS2370 from damage caused by transients during hot plug events. The transorb or zener diode should be selected such that it does not zener below the maximum required application voltage of 57 V, but before reaching the 68-V absolute maximum rating. For layout purposes, the 0.1- μ F capacitor should be placed as close as possible to the device; the transorb or zener diode should be placed as close to the supply connector as possible. Based on the nature of the PD application, these measures should be considered an implementation requirement.

USE OF BARREL RECTIFIERS

Many applications use barrel rectifiers after the RJ-45 connector in order to be polarity insensitive. Barrel rectifiers in front of the TPS2370 cause the voltages at the device to be lower than the voltages at the RJ-45. The TPS2370 allows for this and is IEEE802.3af compliant during the detection and classification phases. For the detection phase, the device begins detection for voltages as low as 1.3 V across the supply pins. For the optional classification phase, the device is guaranteed to start classification below 14 V across the supply pins. Once classification has been engaged, it becomes latched-in and further voltage drops due to cable resistance and class current does not cause it to switch out of classification. Thus, the TPS2370 allows for at least a 1.5-V drop between the RJ-45 and the TPS2370 due to barrel rectifiers during both detection and classification phases.

However, in cases where the PSE is operating at the minimum class voltage (15.5 V) and there is a 20- Ω , 100-m cable between the PSE and the PD, class 3 devices may not classify correctly when using barrel rectifiers. Class 3 device designs should include Schottky diodes to handle all corner cases, or switch to class 0 devices when using barrel rectifiers.

THERMAL SHUTDOWN

In the event of a short circuit or overload condition, the TPS2370 begins to heat up until thermal shutdown is reached. Once thermal shutdown is reached, the internal FET is switched off, removing the load from the supply. After the device has cooled sufficiently, it retries by restarting the internal FET. If the overload or short is not removed, the device cycles thermal shutdown seven times before latching the internal FET off. Once the internal FET is latched off, power needs to be cycled to reset the latch.

APPLICATION INFORMATION

Figure 1 shows an application where $40\text{ V} < V_{IN} < 57\text{ V}$. In this case, the brick supply is greater than 40 V and goes through TPS2370.

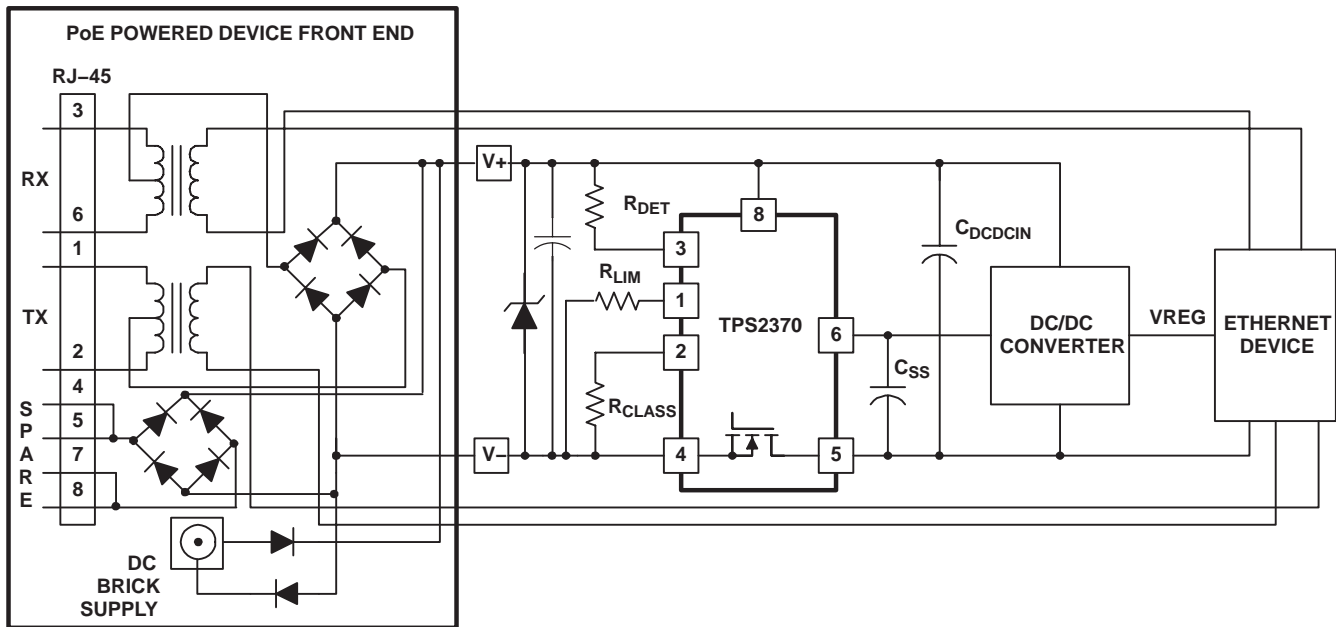

Figure 1. For Applications $40\text{ V} < V_{IN} < 57\text{ V}$.

Figure 2 shows an application where $V_{IN} < 40\text{ V}$. In this application, the brick supply is bypassing the switch. Consequently, the dc-to-dc converter can operate from any voltage. However, for $V_{BRICK} < 23\text{ V}$, a class 0 resistor ($R_{CLASS} = 4.42\text{ k}\Omega$) is recommended. This minimizes the power dissipation in TPS2370 if V_{BRICK} falls in the classification voltage range (15 V to 20 V). The 80- μA current sink on EN_DC pin is enabled only if $V_{DD} > 40\text{ V}$.

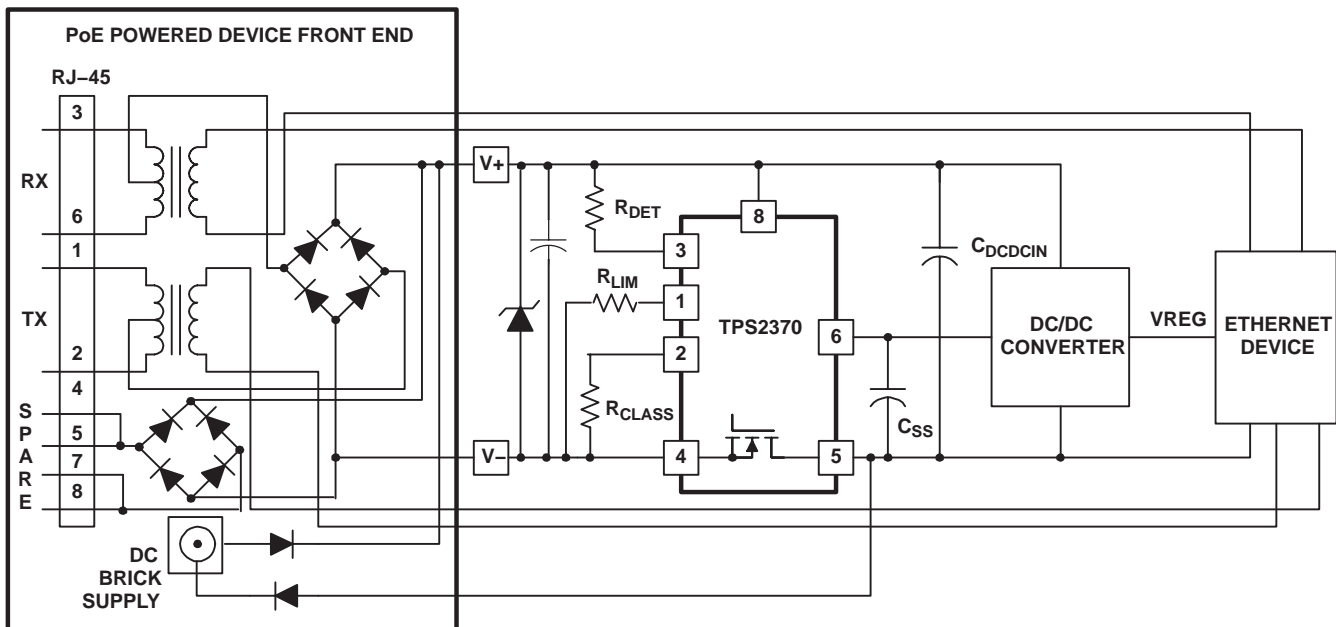

Figure 2. For Applications $V_{IN} < 40\text{ V}$.

PACKAGING INFORMATION

Orderable Device	Status (1)	Package Type	Package Drawing	Pins	Package Qty	Eco Plan (2)	Lead finish/ Ball material (6)	MSL Peak Temp (3)	Op Temp (°C)	Device Marking (4/5)	Samples
TPS2370PW	NRND	TSSOP	PW	8	150	RoHS & Green	NIPDAU	Level-1-260C-UNLIM	0 to 70	2370	
TPS2370PWR	NRND	TSSOP	PW	8	2000	RoHS & Green	NIPDAU	Level-1-260C-UNLIM	0 to 70	2370	

(1) The marketing status values are defined as follows:

ACTIVE: Product device recommended for new designs.

LIFEBUY: TI has announced that the device will be discontinued, and a lifetime-buy period is in effect.

NRND: Not recommended for new designs. Device is in production to support existing customers, but TI does not recommend using this part in a new design.

PREVIEW: Device has been announced but is not in production. Samples may or may not be available.

OBSOLETE: TI has discontinued the production of the device.

(2) **RoHS:** TI defines "RoHS" to mean semiconductor products that are compliant with the current EU RoHS requirements for all 10 RoHS substances, including the requirement that RoHS substance do not exceed 0.1% by weight in homogeneous materials. Where designed to be soldered at high temperatures, "RoHS" products are suitable for use in specified lead-free processes. TI may reference these types of products as "Pb-Free".

RoHS Exempt: TI defines "RoHS Exempt" to mean products that contain lead but are compliant with EU RoHS pursuant to a specific EU RoHS exemption.

Green: TI defines "Green" to mean the content of Chlorine (Cl) and Bromine (Br) based flame retardants meet JS709B low halogen requirements of <=1000ppm threshold. Antimony trioxide based flame retardants must also meet the <=1000ppm threshold requirement.

(3) MSL, Peak Temp. - The Moisture Sensitivity Level rating according to the JEDEC industry standard classifications, and peak solder temperature.

(4) There may be additional marking, which relates to the logo, the lot trace code information, or the environmental category on the device.

(5) Multiple Device Markings will be inside parentheses. Only one Device Marking contained in parentheses and separated by a "~" will appear on a device. If a line is indented then it is a continuation of the previous line and the two combined represent the entire Device Marking for that device.

(6) Lead finish/Ball material - Orderable Devices may have multiple material finish options. Finish options are separated by a vertical ruled line. Lead finish/Ball material values may wrap to two lines if the finish value exceeds the maximum column width.

Important Information and Disclaimer:The information provided on this page represents TI's knowledge and belief as of the date that it is provided. TI bases its knowledge and belief on information provided by third parties, and makes no representation or warranty as to the accuracy of such information. Efforts are underway to better integrate information from third parties. TI has taken and continues to take reasonable steps to provide representative and accurate information but may not have conducted destructive testing or chemical analysis on incoming materials and chemicals. TI and TI suppliers consider certain information to be proprietary, and thus CAS numbers and other limited information may not be available for release.

In no event shall TI's liability arising out of such information exceed the total purchase price of the TI part(s) at issue in this document sold by TI to Customer on an annual basis.

TAPE AND REEL INFORMATION



QUADRANT ASSIGNMENTS FOR PIN 1 ORIENTATION IN TAPE



*All dimensions are nominal

Device	Package Type	Package Drawing	Pins	SPQ	Reel Diameter (mm)	Reel Width W1 (mm)	A0 (mm)	B0 (mm)	K0 (mm)	P1 (mm)	W (mm)	Pin1 Quadrant
TPS2370PWR	TSSOP	PW	8	2000	330.0	12.4	7.0	3.6	1.6	8.0	12.0	Q1

TAPE AND REEL BOX DIMENSIONS



*All dimensions are nominal

Device	Package Type	Package Drawing	Pins	SPQ	Length (mm)	Width (mm)	Height (mm)
TPS2370PWR	TSSOP	PW	8	2000	853.0	449.0	35.0

PW0008A



PACKAGE OUTLINE
TSSOP - 1.2 mm max height

SMALL OUTLINE PACKAGE



4221848/A 02/2015

NOTES:

1. All linear dimensions are in millimeters. Any dimensions in parenthesis are for reference only. Dimensioning and tolerancing per ASME Y14.5M.
2. This drawing is subject to change without notice.
3. This dimension does not include mold flash, protrusions, or gate burrs. Mold flash, protrusions, or gate burrs shall not exceed 0.15 mm per side.
4. This dimension does not include interlead flash. Interlead flash shall not exceed 0.25 mm per side.
5. Reference JEDEC registration MO-153, variation AA.

EXAMPLE BOARD LAYOUT

PW0008A

TSSOP - 1.2 mm max height

SMALL OUTLINE PACKAGE



LAND PATTERN EXAMPLE
SCALE:10X



SOLDER MASK DETAILS
NOT TO SCALE

4221848/A 02/2015

NOTES: (continued)

- 6. Publication IPC-7351 may have alternate designs.
- 7. Solder mask tolerances between and around signal pads can vary based on board fabrication site.

EXAMPLE STENCIL DESIGN

PW0008A

TSSOP - 1.2 mm max height

SMALL OUTLINE PACKAGE



SOLDER PASTE EXAMPLE
BASED ON 0.125 mm THICK STENCIL
SCALE:10X

4221848/A 02/2015

NOTES: (continued)

8. Laser cutting apertures with trapezoidal walls and rounded corners may offer better paste release. IPC-7525 may have alternate design recommendations.
9. Board assembly site may have different recommendations for stencil design.

IMPORTANT NOTICE AND DISCLAIMER

TI PROVIDES TECHNICAL AND RELIABILITY DATA (INCLUDING DATASHEETS), DESIGN RESOURCES (INCLUDING REFERENCE DESIGNS), APPLICATION OR OTHER DESIGN ADVICE, WEB TOOLS, SAFETY INFORMATION, AND OTHER RESOURCES "AS IS" AND WITH ALL FAULTS, AND DISCLAIMS ALL WARRANTIES, EXPRESS AND IMPLIED, INCLUDING WITHOUT LIMITATION ANY IMPLIED WARRANTIES OF MERCHANTABILITY, FITNESS FOR A PARTICULAR PURPOSE OR NON-INFRINGEMENT OF THIRD PARTY INTELLECTUAL PROPERTY RIGHTS.

These resources are intended for skilled developers designing with TI products. You are solely responsible for (1) selecting the appropriate TI products for your application, (2) designing, validating and testing your application, and (3) ensuring your application meets applicable standards, and any other safety, security, or other requirements. These resources are subject to change without notice. TI grants you permission to use these resources only for development of an application that uses the TI products described in the resource. Other reproduction and display of these resources is prohibited. No license is granted to any other TI intellectual property right or to any third party intellectual property right. TI disclaims responsibility for, and you will fully indemnify TI and its representatives against, any claims, damages, costs, losses, and liabilities arising out of your use of these resources.

TI's products are provided subject to TI's Terms of Sale (www.ti.com/legal/termsofsale.html) or other applicable terms available either on ti.com or provided in conjunction with such TI products. TI's provision of these resources does not expand or otherwise alter TI's applicable warranties or warranty disclaimers for TI products.

Mailing Address: Texas Instruments, Post Office Box 655303, Dallas, Texas 75265
Copyright © 2020, Texas Instruments Incorporated