

molex[®]

PUTT PUMP HYDRAULIC HEAD CRIMPER

(With Optional Bench Mounting)

Operation Manual

Eng. No. PPHLS-CS

Order No. 19286-0117

For Insulated and Non-Insulated Terminal and Splices

- Description
- Operation
- Maintenance

Table of Contents

SECTION

1	Safety Warnings
2	General Description
3	Setup and Adjustments
4	Crimping Dies Go-No go
5	Preventive Maintenance
6	Parts List, Assembly Drawings and Troubleshooting

WARNING

MOLEX CANNOT BE RESPONSIBLE FOR DAMAGE OR INJURY RESULTING FROM UNSAFE PRODUCT USE, LACK OF MAINTENANCE, OR INCORRECT PRODUCT AND SYSTEM APPLICATION.

All WARNINGS must be carefully observed to help prevent personal injury.

AIR/HYDRAULIC PUMP

HAND/FOOT OPERATED - MAXIMUM CAPACITY:
10,000 PSI

WARNING Before operating the hydraulic pump, all hose connections must be tightened with proper tools. Do not over-tighten. Connections need only be tightened securely and leak-free. Over-tightening may cause premature thread failure or may cause high-pressure fittings to split at pressures lower than their rated capacities.

WARNING Should a hydraulic hose ever rupture, burst, or need to be disconnected, immediately shut off the pump and shift the control valve twice to release all pressure. Never attempt to grasp a leaking hose under pressure with your hands. The force of escaping hydraulic fluid could cause serious injury.

WARNING Do not subject the hose to potential hazard such as fire, extreme heat or cold, sharp surfaces, or heavy impact. Do not allow the hose to kink, twist, curl, or bend so tightly that the oil flow within the hose is blocked or reduced. Periodically inspect the hose for wear because any of these conditions can damage the hose and possibly result in personal injury.

WARNING Do not use the hose to move attached equipment. Stress may damage hose and possibly cause personal injury.

WARNING Hose material and coupler seals must be compatible with the hydraulic fluid used.

Hoses must not encounter corrosive materials such as creosote-impregnated objects and some paints. Consult the manufacturer before painting a hose. Never paint the couplers. Hose deterioration due to corrosive materials may result in possible personal injury

Pump

WARNING Do not exceed the PSI hydraulic rating noted on the pump nameplate or tamper with the internal high-pressure relief valve. Creating pressure beyond rated capacities may result in personal injury.

WARNING Before replenishing the oil level, retract the system to prevent overfilling the pump reservoir. An overfill may cause personal injury due to excess reservoir pressure created when cylinders are retracted.

Cylinder

WARNING Do not exceed rated capacities of the cylinders. Excess pressure may result in personal injury.

WARNING Do not set poorly balanced or off-center loads on a cylinder. The load may tip and cause personal injury.

Air Supply

WARNING Shut off and disconnect the air supply when the pump is not in use or before breaking any connection in the system.

WARNING MOLEX SPECIFICATIONS ARE VALID ONLY WHEN USED WITH MOLEX TERMINALS AND TOOLING.

WORK SAFELY AT ALL TIMES

**For Service, Contact Your
Local Molex Sales Office**

**Molex Application Tooling Group
2200 Wellington Court
Lisle, Illinois 60532
Tel: 630-969-4550
Fax: 630-505-0049**

Section 2

General Description

- 2.1 Description
- 2.2 Features
- 2.3 Technical Specifications
- 2.4 Delivery Check
- 2.5 Tools

Principal Mechanical Parts of the 19286-0117 (PPHLS)

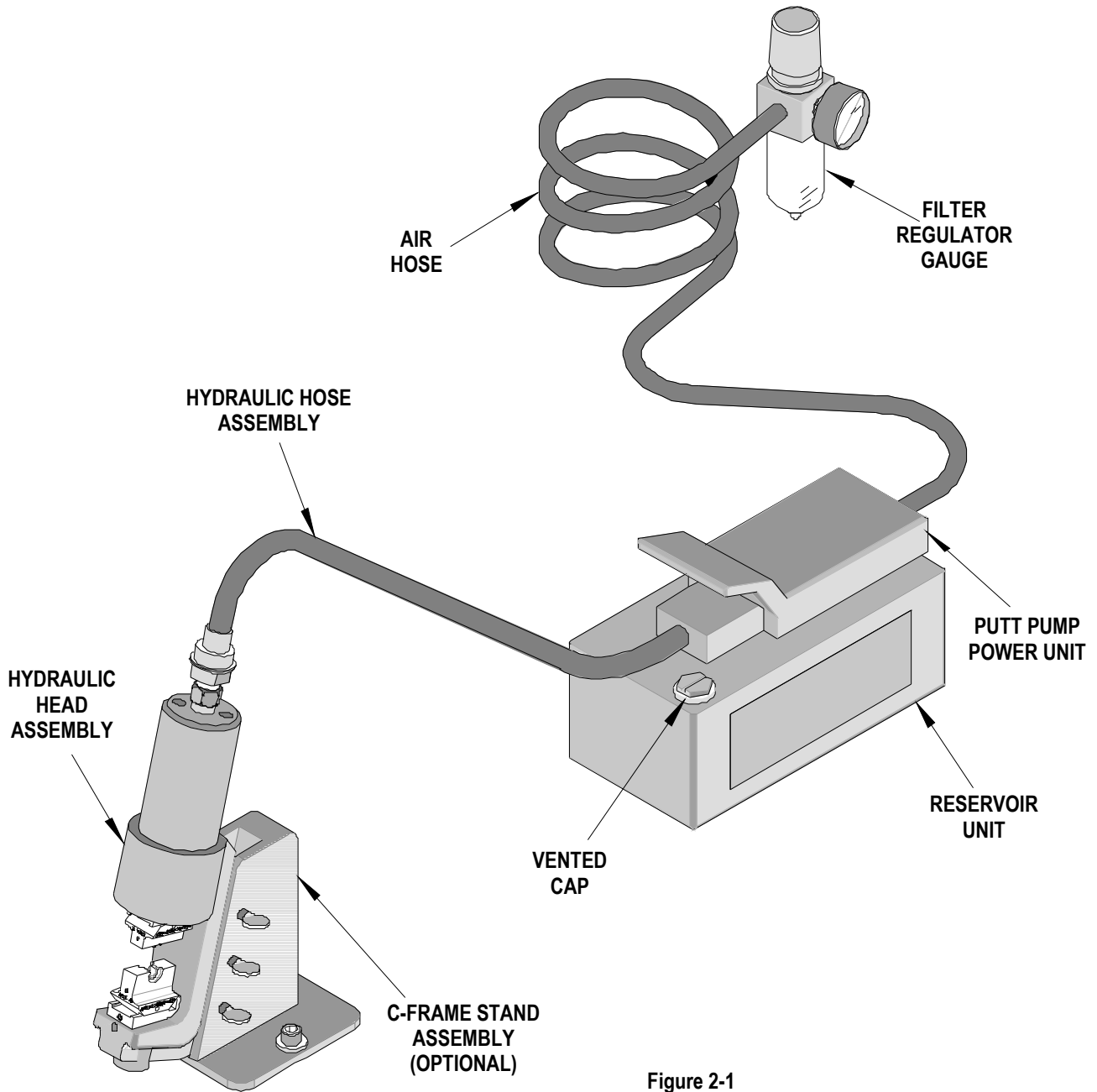

Figure 2-1

General Description

Description

The Molex Putt Pump Hydraulic Head Crimper is designed to crimp 8 to 4/0 AWG insulated and uninsulated terminals and splices.

Features

- Crimps a wide range of products with interchangeable tool kits, which reduce the overall cost and provide production flexibility.
- Crimping dies are easily and quickly interchanged to reduce production down time.
- Complete portable system that allows tool to be moved and stored easily.

Technical Specification

Pneumatic:
Supply Pressure: 100 PSI (6.9 Bars)
125-PSI max. (8.6 Bars max.)

Cycle Time: 15 seconds

Delivery Check

Carefully remove the Putt Pump Hydraulic Head from its shipping container and determine that the following items are included in the package.

- ✓ Hydraulic Head Crimper Tool
- ✓ Pump Assembly with hoses, filter, regulator, and gauge assembly (Includes vented cap for pump)
- ✓ 19286-0117 Instruction Manual

Tools

The following tools are recommended for setup and adjustments to this tool.

1. Metric standard hex wrench set
2. Inch standard hex wrench set
3. Adjustable wrench
4. Wire stripper / cutter
5. Screw driver

Section 3

Set-Up and Adjustments

- 3.1. Setup
- 3.2. Connection and Bench Mounting
- 3.3. Installation of Tool Kits

CAUTION: Always disconnect the air supply until the system is ready to operate.

3.1 Set-Up

The principal mechanical parts of the 19286-0117 are illustrated in Figure 2-1 and Section 6 in this document.

Air Supply Hook-Up

WARNING: Seal all external pipe connections with a high quality, non-hardening pipe sealant. Teflon tape may also be used to seal hydraulic connections if only one layer of tape is used.

1. Select the 1/4 NPT threaded fittings that are compatible with your air supply.
2. Remove the red plastic thread protector from the putt pump on the air connection. Pull out and discard then attach the air fitting.
3. Next, install the fittings to the filter, regulator, and gauge unit. The air supply should be 20 CFM (550 L/M) and 100 PSI (6.9 Bars) to obtain the rated hydraulic output. Air pressure should be regulated to a maximum of 125 PSI (8.6 Bars). See Figure 3-1.
4. Before installing the hydraulic hose, unscrew the square nut on the putt pump outlet and discard. Attach the hose assembly to the hydraulic fluid outlet.

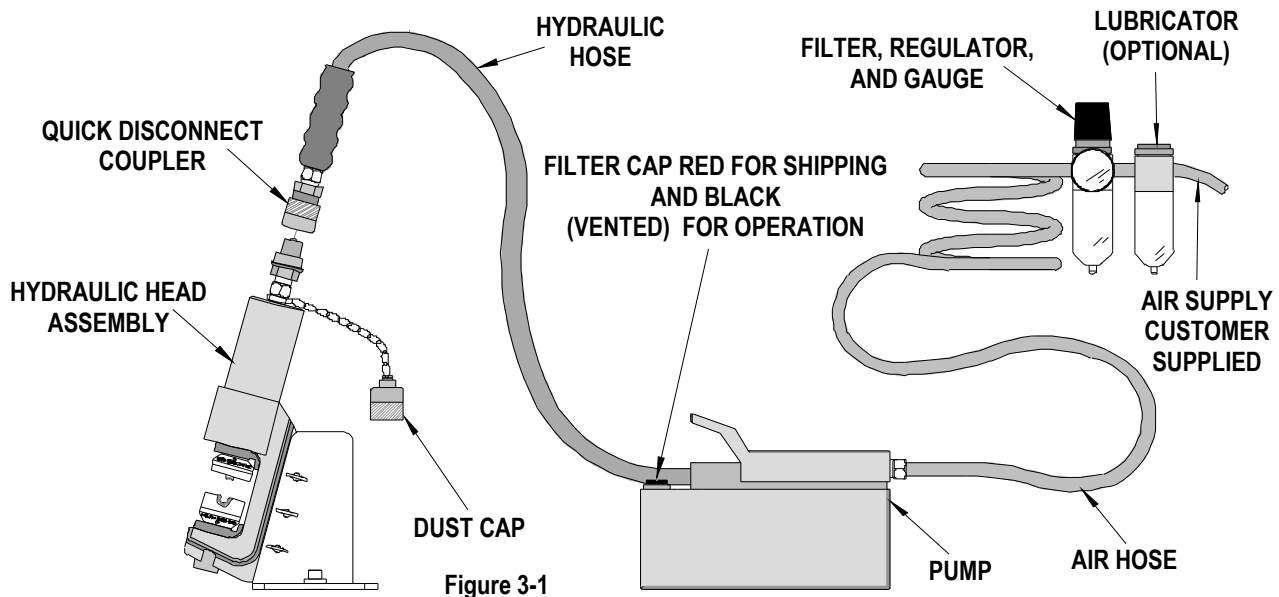

3.2 Hydraulic Connections and Optional Bench Mounting

1. Remove the dust cap from the cylinder on the crimp head.
2. Connect the quick disconnect coupler onto the cylinder inlet on the crimp head. See figure 3-1.
3. Replace the red filler cap on the pump reservoir with the black-vented cap that is supplied with the unit.
4. To mount the hydraulic head assembly to the optional C-Frame stand, loosen the three thumbscrews in the stand and place the hydraulic head in the stand with the cylinder facing up. Tighten the thumbscrews; making sure the hydraulic head is securely positioned. See Figure 3-2.

- When using the optional C-Frame stand, be sure the C-Frame stand assembly is securely fastened to a clean, sturdy workbench or table in a well-lighted area. Fasten the stand with two #3/8-16 SHCSs, nuts, and washers of sufficient length for the tabletop. (Not supplied). See Figure 3-3. (Some stands may have four mounting holes instead of two.)

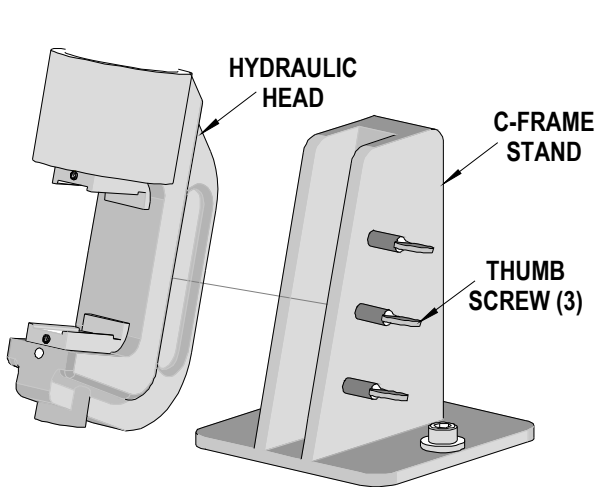

Figure 3-2

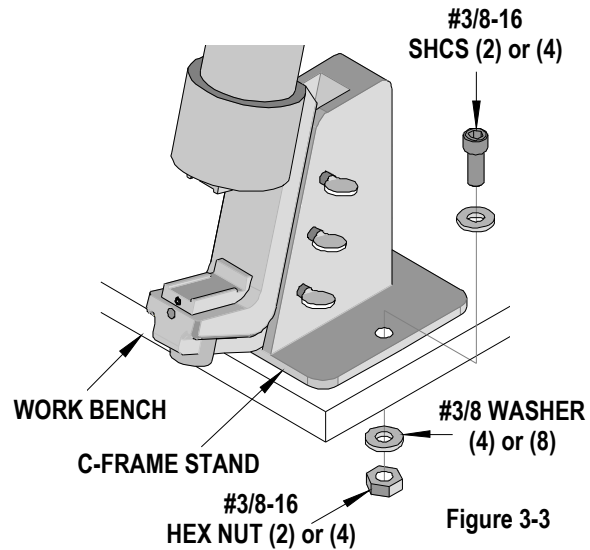

Figure 3-3

3.3 Installation of Tool Kits

CAUTION: Always disconnect the air supply until the system is ready to operate

Before crimping, set the recommended air pressure gauge for the hydraulic pump (See Section 3.1) to obtain the proper crimp.

- Connect the female coupler firmly with the male coupler of high-pressure rubber hose, which is attached to the hydraulic pump.
- Select the proper set of dies for the terminal being crimped. The wire size is marked on each die. See Section 4.3.

CAUTION: Be sure to use the correct pair of dies for the appropriate wire and terminal.

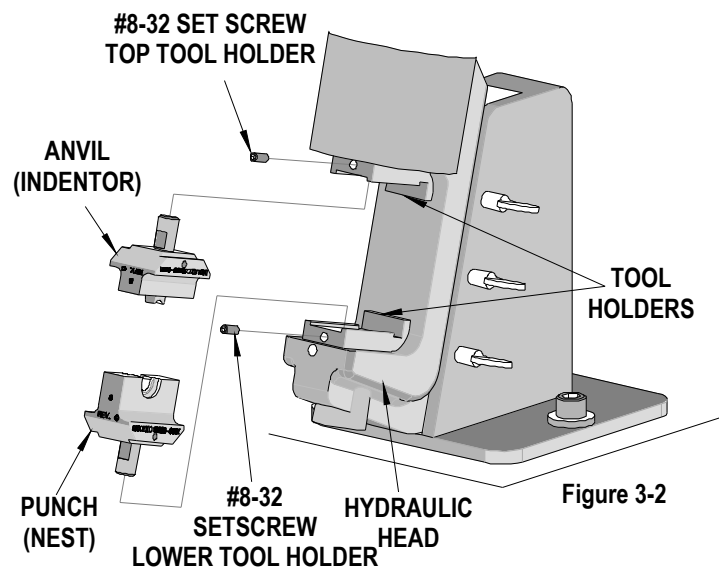

Figure 3-2

3. Loosen the #8-32 setscrew in the upper tool holder in the hydraulic head assembly. Place the anvil (Indentor) in the top tool holder and retighten the setscrew. See Figure 3-2.
4. Loosen the #8-32 set screw in the lower tool holder in the hydraulic head assembly. Then, place the punch (Nest) in the lower tool holder of the hydraulic head assembly and retighten the setscrew. The punch (Nest) is always placed on the bottom holder to help locate and hold the terminal and wire before crimping.

CAUTION: A wrong combination of dies may cause critical damage to the tool.

Section 4

Terminal Specifications and Crimping Operation

- 4.1 Scope
- 4.2 Terminal Specifications Chart
- 4.3 Crimping Terminals

4.1 SCOPE

This tooling is designed to crimp Molex Versakrimp™ BCL's, Nylakrimp®, and Insulkrimp® in the 8-4/0 AWG range.

Testing Mechanical

The tensile test, or pull test, is a means of evaluating the mechanical properties of the crimped connections. The following charts show the UL specifications for various wire sizes. The tensile strength is shown in pounds, which indicates the minimum acceptable force to break or separate the terminal from the conductor.

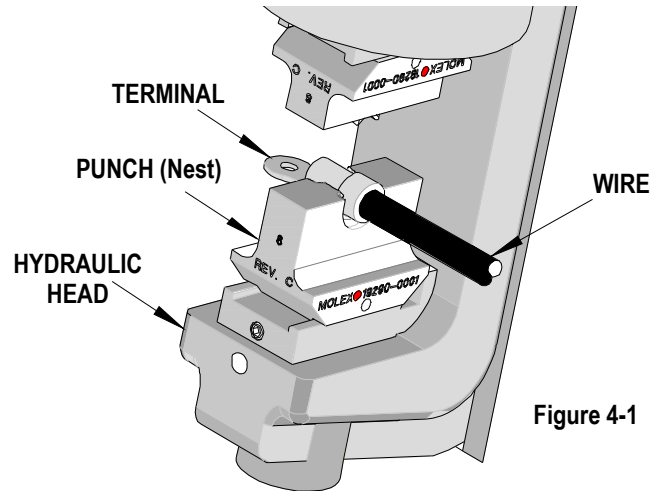

Wire Size (AWG)	Tooling Color Code	*UL – 486A	**UL – 486C	***MIL-T-7928
8	Red	90	45	225
6	Blue	100	50	300
4	Yellow	140	-	400
2	Red	180	-	550
1	Blue	200	-	650
1/0	Blue	250	-	700
2/0	Yellow	300	-	750
3/0	Red	350	-	825
4/0	Blue	450	-	875

*UL – 486A – Terminals (Copper Conductors Only)

**UL – 486C – Butt Slices and Parallel Slices (Over 6 AWG use 486A values)

***MIL-T-7928 - Military Approved Terminals only as listed

4.2 Crimping Terminals

Before crimping, set the recommended air pressure gauge to obtain the proper crimp. See Section 3.1.

1. Insert the properly stripped wire into the terminal barrel.
2. Position the terminal and wire into the center of the punch (Nest), centering the terminal barrel with the tooling. See Figure 4-1 and 4-2.
3. Depress the pedal on the putt pump to activate the tool. The crimping process is done in small increments gradually allowing the press to fully crimp the terminal into the wire.
4. After the terminal is fully crimp, depress the elevated portion of the pedal to release the pump. This will allow the tool to release.
5. Remove the crimp and inspect for proper crimp location.

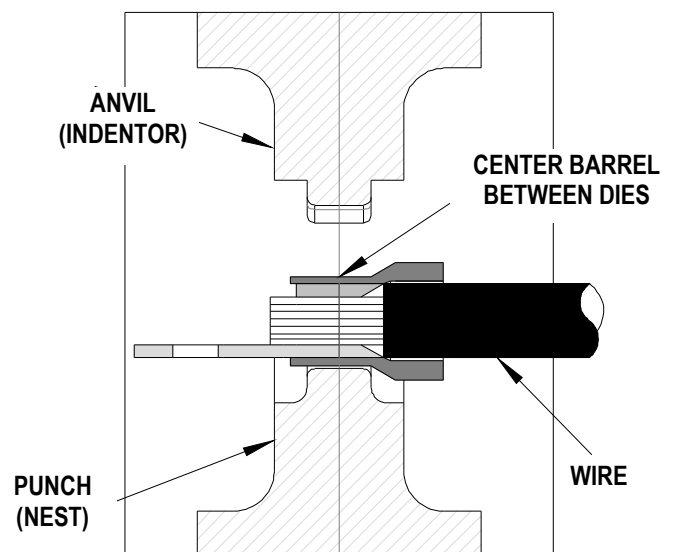
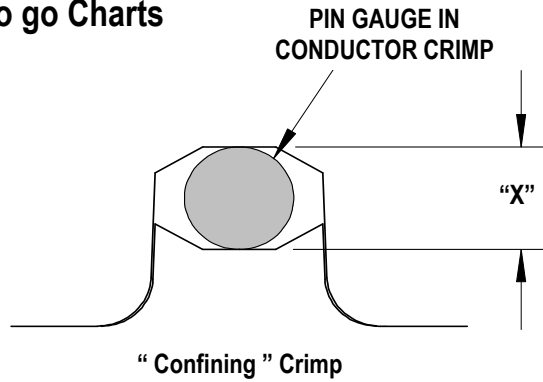

Figure 4-2

4.3 Crimping Die Go-No go Charts



Versakrimp™ and “BCL” Non-Insulated Products

Die Set Order No.	Die Set Engineering No. (REF)	Wire Size		“X” Dimension Conductor Crimp			
				Go		No Go	
		AWG	mm ²	In	mm	In	mm
19290-0001	HHL-D-110	8	6.6-10.5	.149	3.78	.161	4.09
19290-0004	HHL-E-120	6	10.5-16.8	.214	5.44	.226	5.74
19290-0007	HHL-F-130	4	16.8-26.6	.233	5.91	.245	6.22
19290-0010	HHL-G-140	2	26.6-42.4	.269	6.83	.281	7.14
19290-0011	HHL-H-150	★ 1	42.4-60.5	.318	8.07	.330	8.38
19290-0011	HHL-H-150	1/0	42.4-60.5	.318	8.07	.330	8.38
19290-0012	HHL-J-160	2/0	60.5-76.2	.376	9.55	.388	9.86
19290-0028	HHL-K-170	3/0	76.2-96.3	.396	10.06	.408	10.36
19290-0031	HHL-L-180	4/0	96.3-117.0	.424	10.71	.436	11.07

★ BCL Products Only

Nylakrimp® and Insulkrimp® Insulated Products

Die Set Order No.	Die Set Engineering No. (REF)	Wire Size		“X” Dimension Conductor Crimp			
				Go		No Go	
		AWG	mm ²	In	mm	In	mm
19289-0001	HHL-D-710	8	6.6-10.5	.214	5.44	.226	5.74
19289-0004	HHL-E-720	6	10.5-16.8	.245	6.22	.257	6.53
19289-0007	HHL-F-730	4	16.8-26.6	.334	8.48	.346	8.79
19289-0010	HHL-G-740	2	26.6-42.4	.330	8.38	.342	8.69
19289-0011	HHL-H-750	1/0	42.4-60.5	.381	9.68	.393	9.98
19289-0025	HHL-J-760	2/0	60.5-76.2	.419	10.64	.431	10.95
19289-0028	HHL-K-770	3/0	76.2-96.3	.511	12.98	.523	13.28
19289-0031	HHL-L-780	4/0	96.3-117.0	.574	14.58	.586	14.88

Note: This Hydraulic Tool also accepts older style HHS Tool Kits.

Section 5

Preventive Maintenance

- 5.1 Lubrication
- 5.2 Bleeding Air From the System
- 5.3 Inspecting the Hydraulic Fluid Level
- 5.4 Draining and Flushing the Reservoir
- 5.5 Refilling the Reservoir
- 5.6 Venting the Reservoir
- 5.7 Priming the Pump Unit
- 5.8 Periodic Cleaning
- 5.9 Spare Parts
- 5.10 Perishable Parts
- 5.11 Storage

5.1 Lubrication

WARNING: Any repair or servicing, which requires dismantling the pump must be performed in a dirt-free environment by a qualified technician.

CAUTION: Always disconnect air supply before all maintenance.

If the pump is operated on a continuous duty cycle for extended periods, the manufacturer recommends an automatic airline oiler be installed in the air inlet as close to the pumping unit as possible.

Set the unit to feed approximately 1 drop of oil per minute into the system. Use SAE No. 10 oil.

5.2 Bleeding Air From The System

During the initial moments of activation or after prolonged use, a significant amount of air may accumulate within the hydraulic system. This entrapped air may cause the cylinder to respond slowly or behave in an unstable manner.

To remove the air, run the system through several cycles (extending and retracting the ram) free of any load. The rams must be at a lower level than the pump to allow air to be released through the pump reservoir.

5.3 Inspecting The Hydraulic Fluid Level

CAUTION: Always disconnect air supply before all maintenance.

1. Check the oil level in the reservoir after every 10 hours of use.
2. The oil level should come to within 1/2" of the filler plug with all hoses attached.
3. Drain and replenish the reservoir with an approved, high-grade hydraulic oil such as OTC 16355 after every 300 hours of use.

Hoses: Hydraulic hoses on this unit carry a rating of 10,000 PSI.

Replacement hoses must carry the same rating.

5.4 Draining and Flushing the Reservoir

IMPORTANT: Wipe the pump exterior completely clean before attempting this procedure!

1. Loosen and remove the six screws that fasten the pump assembly to the reservoir. Remove the pump assembly from the reservoir. Do not damage the gasket, filter, or safety valve.
2. Clean the inside of the reservoir and refill with a suitable, non-flammable flushing oil. Rinse the filter clean.
3. Place the pump assembly back onto the reservoir and secure with two of the six screws. For best results, assemble the screws in opposite corners of the housing.
4. Run the unit for several minutes. Use the same method described in Section 3-7 (Priming the pump unit)
5. Drain and clean the reservoir once more.
6. Refill the reservoir with an approved, clean hydraulic oil and replace the pump assembly (with gasket) on the reservoir. Assemble the six machine screws and torque 25 to 30 in. lbs.

IMPORTANT: Drain and clean the other hydraulic system components (hoses, cylinders, etc.) before reconnecting them to the pump. This will prevent contaminated oil from re-entering the pump.

5.5 Refilling The Reservoir

CAUTION: Always disconnect air supply before all maintenance.

1. If additional oil must be added to the reservoir, use only an approved high-grade hydraulic oil such as OTC 16355 (215 SSU @ 100° F).
2. Clean the entire area around the filler plug before adding oil to the reservoir.
3. Remove the filler plug and insert a clean funnel with filter.
4. The ram must be fully retracted and the air supply disconnected when adding the oil to the reservoir.

5.6 Venting the Reservoir

To improve oil delivery and increase useable oil capacity, vent the reservoir by removing the vent screw from the filler plug before using the pump. See Figure 5-1.

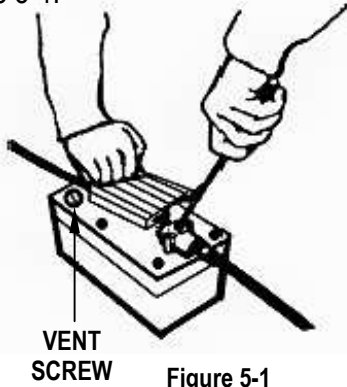

Figure 5-1

5.7 Priming the Pump Unit

If the pump unit must be primed, perform the following procedure:

1. Depress the release end of the pedal while holding down the air intake valve with a flathead screwdriver. The air intake valve is located directly under the pedal in the area marked PUMP. This "button" is depressed simultaneously with the RELEASE area of the pedal during priming.
2. Allow the pump to cycle approximately 15 seconds.

3. Remove the screwdriver and depress the pump end of the pedal once more.
4. If the ram extends or pressure builds, the pump has been successfully primed.
5. If the pump does not respond, repeat the procedure, repeatedly jogging the air intake valve while holding the pedal in the RELEASE position.

5.8 Periodic Cleaning

CAUTION: Always disconnect air pressure supply before all maintenance

A routine should be established to keep the pump as free from dirt as possible.

1. All unused couplers should be sealed with thread protectors.
2. All hose connections must be free of grit and grime.
3. Any equipment hooked up to the pump should also be kept clean.
4. Use only approved, clean hydraulic oil, such as OTC 16355 in this unit and change as recommended (every 300 hours).

An example of a maintenance chart is shown below. Copy and use this chart to track the maintenance of your 19286-0117 or use this as a template to create you own schedule or use your company's standard chart, if applicable.

Preventive Maintenance Chart

Daily: Clean. See Section 5.5.

As Required: Lubricate. See Section 5.1.

CHECK SHEET MONTH _____ YEAR _____

Week	Daily Use	Days of the Week							Solution
		MON	TUE	WED	THU	FRI	SAT	SUN	
1									
2									
3									
4									
Lubrication	1 drop per minute into the system								Use SAE No. 10 Oil
Change Hydraulic oil	300 Hours								Use OTC 16355
Bleeding Air From the System	After prolong use								Run the system thru several cycles.
Refilling Reservoir	10 hours or when needed								Use 215 SSU@100°F (otc 16355)
Cleaning	Hose connections free of grit and dirt. Pump kept clean								Use soft cloth

Schedule should be adjusted up or down depending on usage. Molex recommends that a log of preventive maintenance be kept with the tool.

5.9 Spare Parts

Customers are responsible for maintaining the tool. Spare parts are available from Molex. Moving and functioning parts can be damaged or wear out over time and will require replacement. Molex recommends that the customer keep some or all of them in stock to reduce production down time.

5.10 Perishable Parts (Tool Kits)

Customers are responsible for maintaining the 19286-0117. Perishable parts are those parts that come in contact with the product and will wear out over time. Molex recommends that all customers keep at least one set of the perishable tooling in stock at all times. This will reduce the amount of production down time.

5.11 Storage

When storing the 19286-0117 assembly, disconnect the air supply and store in a dry location. If the pump is disconnected from the hydraulic head, reinstall the dust cap on the cylinder inlet. When transporting, reinstall the red-vented cap on the pump reservoir.

Section 6

- 6.1. Parts Lists and Assembly Drawing
- 6.2. Troubleshooting

6.1 Main Parts List and Assembly Drawings

19286-0117 - Main Assembly Figure 6-1			
Item	Order No.	Description	Qty
1	19286-0041	Hydraulic Hose Assembly-6 Feet	1
2	19286-0049	Filter Regulator with Gauge	1
3	19286-0059	Putt Pump Power Unit	1
4	19286-0103	Air Hose 1/4 NPT Male Fitting-10 Feet	1
5	19286-0051	C-Frame Stand Assembly	★ Optional
6	19286-0005	Hydraulic Head Assembly	1 (Figure 6-2)
7	19286-0006	HHLS Tool Holder	2
★ Order separately			

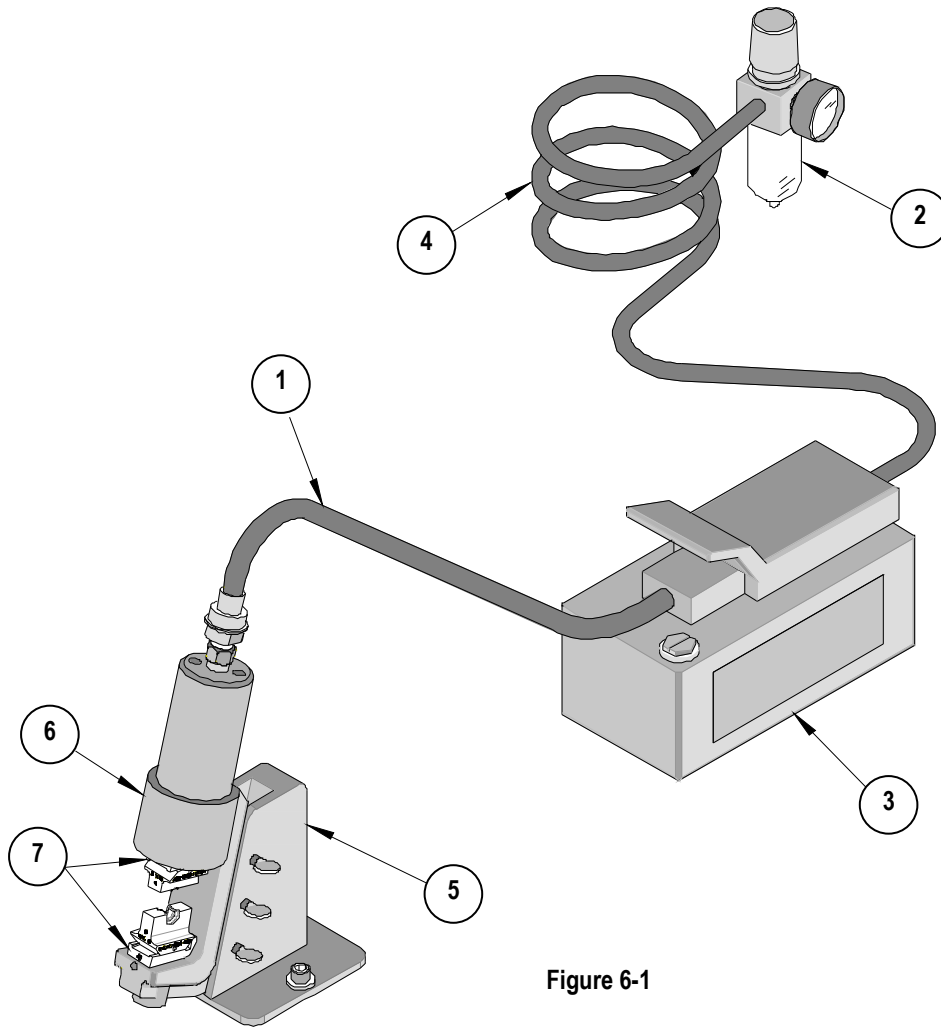

Figure 6-1

6.1 Parts List

19286-0005 Figure 6-2				
Item	Order No.	Eng No.	Description	Qty
1	N/A	N/A	M4x6 Screw (F.P.)	2 K
2	N/A	N/A	Spring (200)	2 K
3	N/A	N/A	1/8" Ball	2 K
4	N/A	N/A	Head Casting	1
5	N/A	N/A	Stopper	1 K
6	N/A	N/A	M5 Lock Washer	1 K
7	N/A	N/A	M5x10 Screw	1 K
8	N/A	N/A	SER-40Scraper	1 K
9	N/A	N/A	Spring Anchor Screw (2)	1 K
10	N/A	N/A	P7-Back-Up Ring (B.C.)	1 K
11	N/A	N/A	P7-O-Ring	1 K
12	19286-0079	510K-05	Cylinder	1
13	N/A	N/A	M5 by8.0LG Screw (C.P.)	1 K
14	19286-0081	510K-07	Ram	1
15	N/A	N/A	P-42 Back-Up Ring (B.C.)	1 K
16	N/A	N/A	P-42 O-Ring	1 K
17	19286-0084	510K-06	17 Spring (307)	1
18	19286-0085	510K-08	End Cap	1
19	19286-0086	FC-8	Female Coupler P.H. Type	1
20	19286-0006	22626	HHLS Die Holder	★2
21	N/A	N/A	#8-32 By 3/4LG Setscrew	2 K
	64000-0102	64000-0102	Repair Kit all "K" Items	REF
★ Order as replacements separately they are not part of 19286-0005.				

6.1 Assembly Drawing

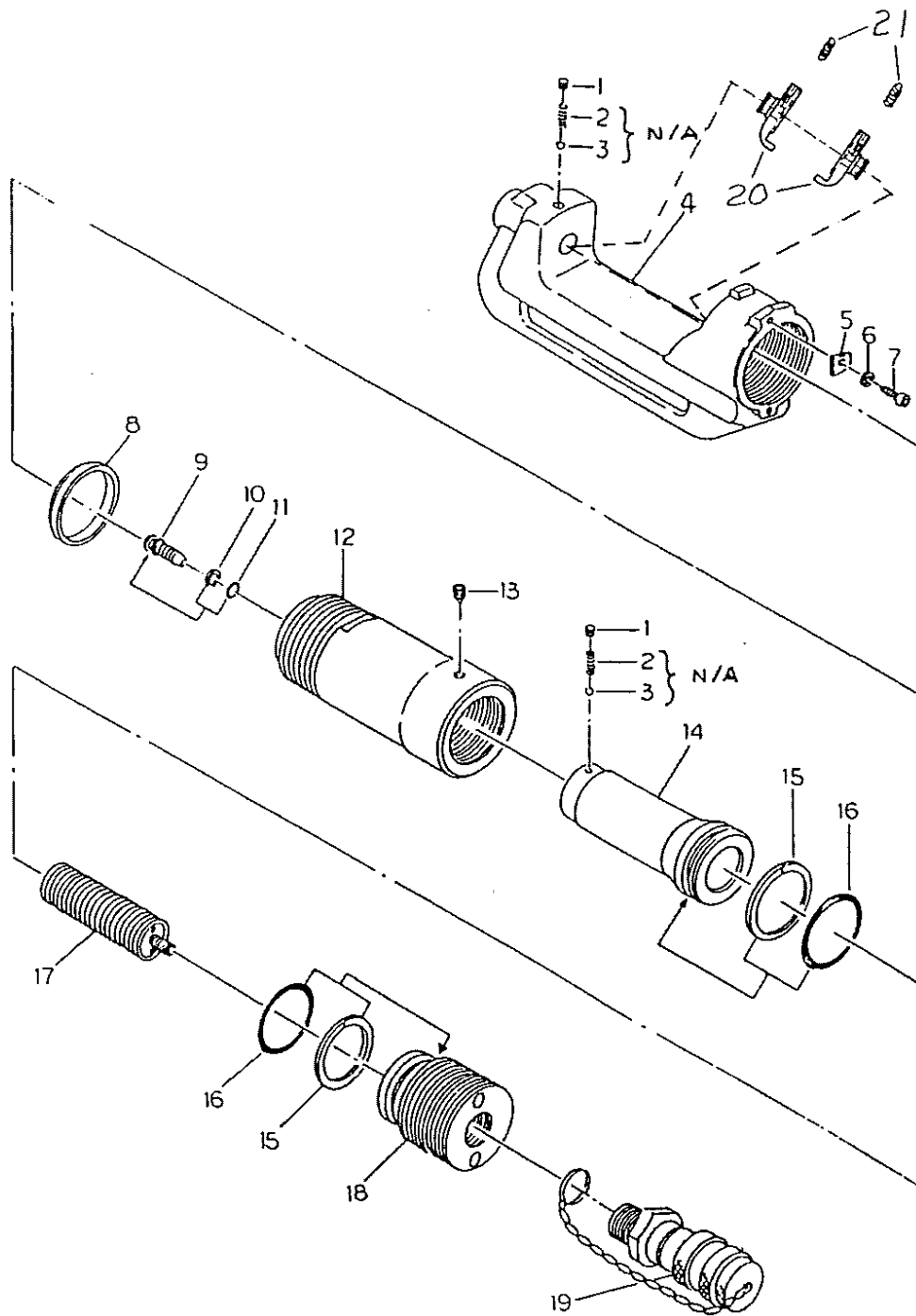

Figure 6-2

6.2 Troubleshooting

Symptom	Cause	Solution
Pump reciprocates but no oil delivery. (Ram will not extend)	▪ Low oil level.	Replenish oil reservoir.
	▪ Pump not primed.	Depress air intake valve and hydraulic release valve simultaneously.
	▪ Check oil filter for contamination.	Invert pump. Fill intake filter with oil. Depress pedal end marked "pump."
Low oil delivery. (Ram extends slowly)	▪ Reservoir not vented	Remove filter and clean.
	▪ Inadequate air supply: 1. Check air input supply. 2. Contamination, check airside of pump. Thoroughly inspect the slot in the air cylinder tub.	1. Should be 20 CFM minimum. 2. Clean and reassemble.
Pump will not build to maximum Pressure. (No visible leakage)	▪ Hydraulic failure: 1. Check the oil filter for contamination. 2. Air in hydraulic system.	1. Clean and reinstall. 2. Bleed the system as described in "Preventative Maintenance" Section.
	▪ Check the air supply.	100 PSI is required to obtain maximum pressure.
Pump builds pressure but will not hold system pressure.	▪ Check hydraulic connections.	Refit as needed.

For more information use the Crimping Testing and Inspection Handbook for Industrial (Closed Barrel products).

There is no charge for this book, which can be found on the Molex Website (www.molex.com) or contact you local Molex sales engineer.

Industrial Crimp Quality Handbook

molex[®]

**INDUSTRIAL CRIMP QUALITY
HANDBOOK
Order No. 64016-0065**

Doc No: TM-640160065 Release Date: 00-00-02 **UNCONTROLLED COPY** Page 1 of 27
Revision: C Revision Date: 12-23-09

<http://www.molex.com>