

Tool Specification

1. Part Number: YC-692R
2. Terminal: BXA-001T-P0.6, BXM-001T-P0.6, BXAM-001T-P0.6
3. Application

Crimp Position	AWG UL1007	Tensile Strength N (Kgf)	Strip Length mm
A	AWG 26	15(1.53) min.	2.2
B	AWG 24	20(2.04) min.	2.2
B	(AWG 22)	(35(3.57) min.)	2.2

Crimp Position

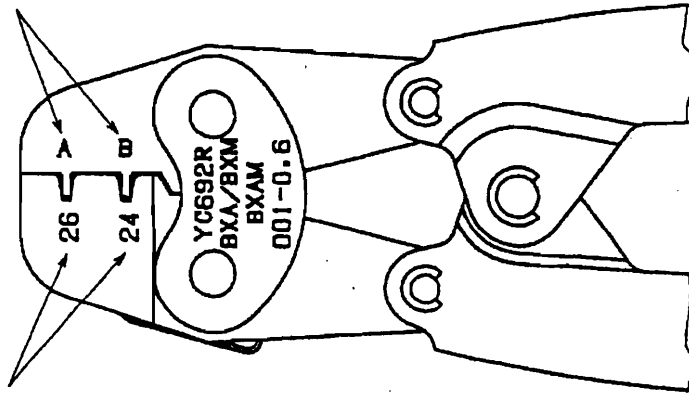

AWG

- Check the crimp appearance and tensile strength prior to use.
- Select the appropriate crimp position based on the AWG that will be used.
- The AWG in () above could cause excessive crimping. Check the tensile strength and crimp appearance to confirm an acceptable crimp.
- The insulation barrel is set for type of wire listed and is not adjustable.