

## General information

**IGBT Stack for typical voltages of up to 690 V<sub>RMS</sub>**  
**Rated output current 1800 A<sub>RMS</sub>**

- High power converter
- Wind power
- Motor drives
- PrimePACK™3 module with integrated NTC
- Extended operational temperature
- Low  $V_{cesat}$

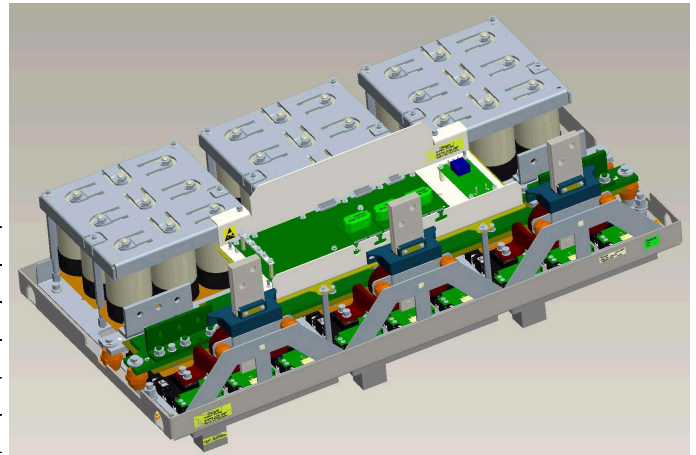

Topology	B6I
Application	Inverter
Load type	Resistive, inductive
Semiconductor (Inverter Section)	9x FF1000R17IE4
DC Link	10.8 mF
Heatsink	Water cooled
Implemented sensors	Current, voltage, temperature
Driver signals IGBT	Electrical
Sales - name	6MS30017E43W33015
SP - No.	SP000840440

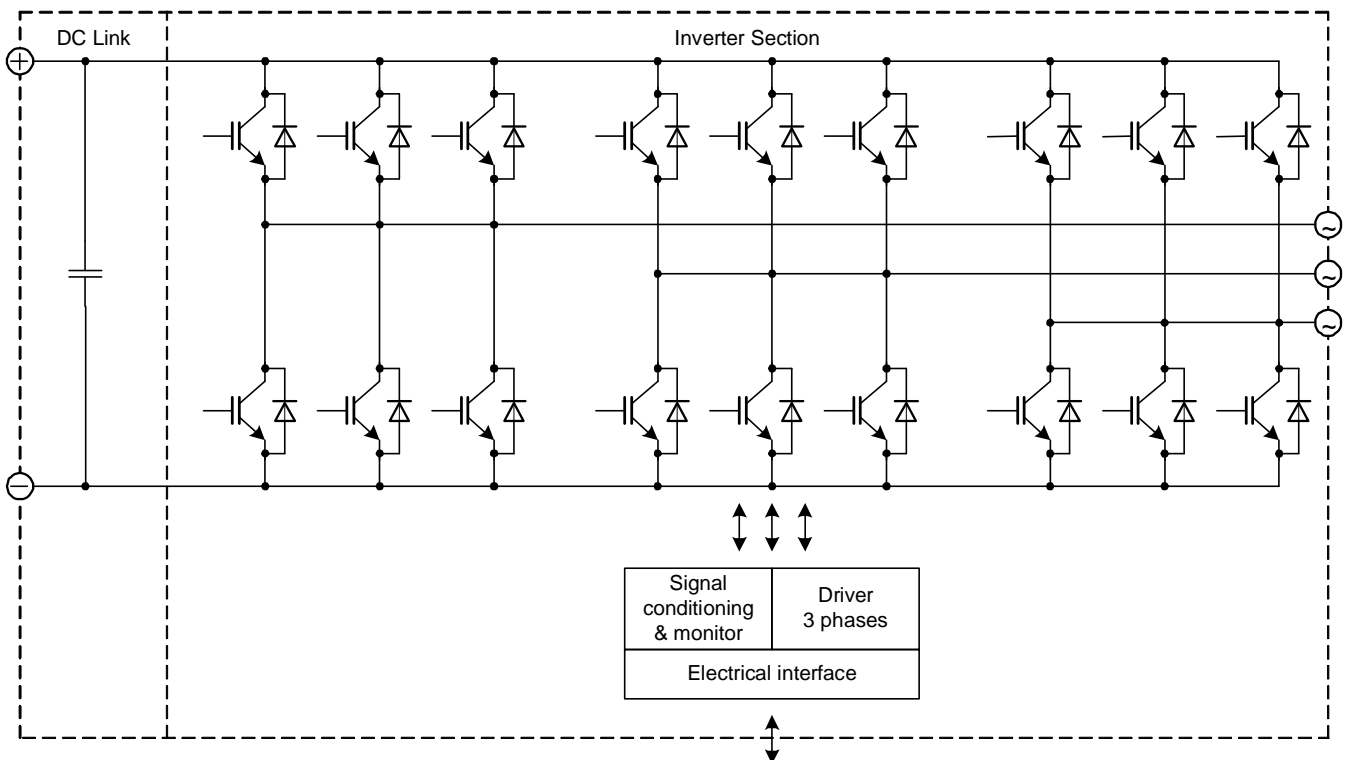

prepared by: AV	date of publication: 2012-04-04
approved by: AR	revision: 2.3

# Technical Information

ModSTACK™ HD

# 6MS30017E43W33015



## Preliminary data

### Absolute maximum rated values

Collector-emitter voltage	IGBT; $T_{vj} = 25^{\circ}\text{C}$	$V_{CES}$	1700	V
Repetitive peak reverse voltage	Diode; $T_{vj} = 25^{\circ}\text{C}$	$V_{RRM}$	1700	V
DC link voltage		$V_{DC}$	1250	V
Insulation management	according to installation height of 2000 m	$V_{line}$	690	$V_{RMS}$
Insulation test voltage	according to EN 50178, $f = 50\text{ Hz}$ , $t = 1\text{ s}$	$V_{ISOL}$	2.5	$kV_{RMS}$
Repetitive peak collector current inverter section (IGBT)	$t_p = 1\text{ ms}$	$I_{CRM2}$	4280	A
Repetitive peak forward current inverter section (Diode)	$t_p = 1\text{ ms}$	$I_{FRM2}$	4280	A
$I^2t$ -value inverter section (Diode)	$V_R = 0\text{ V}$ , $t_p = 10\text{ ms}$ , $T_{vj} = 125^{\circ}\text{C}$	$I^2t$	378	$kA^2s$
Continuous current inverter section		$I_{AC2}$	1800	$A_{RMS}$
Junction temperature	under switching conditions	$T_{vjop}$	150	$^{\circ}\text{C}$
Switching frequency inverter section		$f_{sw2}$	3	kHz

#### Notes

Further maximum ratings are specified in the following dedicated sections

### Characteristic values

#### DC Link

			min.	typ.	max.	
Rated voltage		$V_{DC}$		1100	1200	V
Over voltage shutdown	within 150 $\mu\text{s}$			1250		V
Capacitor	1 s, 27 p, rated tol. $\pm 10\%$	$C_{DC}$		10.8		mF
		type		Foil		
Maximum ripple current	per device, $T_{amb} = 55^{\circ}\text{C}$	$I_{ripple}$			49	$A_{RMS}$
Balance or discharge resistor	per DC link unit	$R_b$		15.7		k $\Omega$

#### Notes

Operation above 1100 V subject to reduced operating time according to EN 61071

#### Inverter Section

			min.	typ.	max.	
Rated continuous current	$V_{DC} = 1100\text{ V}$ , $V_{AC} = 690\text{ V}_{RMS}$ , $\cos(\varphi) = 0.85$ , $f_{AC\ sine} = 50\text{ Hz}$ , $f_{sw} = 3000\text{ Hz}$ , $T_{inlet} = 40^{\circ}\text{C}$ , $T_j \leq 150^{\circ}\text{C}$	$I_{AC}$			1800	$A_{RMS}$
Continuous current at low frequency	$V_{DC} = 1100\text{ V}$ , $f_{AC\ sine} = 0\text{ Hz}$ , $f_{sw} = 3000\text{ Hz}$ , $T_{inlet} = 40^{\circ}\text{C}$ , $T_j \leq 150^{\circ}\text{C}$	$I_{AC\ low}$			880	$A_{RMS}$
Rated continuous current for 150% overload capability	$I_{AC\ 150\%} = 2047\text{ A}_{RMS}$ , $t_{on\ over} = 60\text{ s}$ , $T_j \leq 150^{\circ}\text{C}$	$I_{AC\ over1}$			1365	$A_{RMS}$
Rated continuous current for 150% overload capability	$I_{AC\ 150\%} = 2203\text{ A}_{RMS}$ , $t_{on\ over} = 3\text{ s}$ , $T_j \leq 150^{\circ}\text{C}$	$I_{AC\ over2}$			1468	$A_{RMS}$
Over current shutdown	within 15 $\mu\text{s}$	$I_{AC\ OC}$		4280		$A_{peak}$
Power losses	$I_{AC} = 1800\text{ A}$ , $V_{DC} = 1100\text{ V}$ , $V_{AC} = 690\text{ V}_{RMS}$ , $\cos(\varphi) = 0.85$ , $f_{AC\ sine} = 50\text{ Hz}$ , $f_{sw} = 3000\text{ Hz}$ , $T_{inlet} = 40^{\circ}\text{C}$ , $T_j \leq 150^{\circ}\text{C}$	$P_{loss}$		29140		W

prepared by: AV	date of publication: 2012-04-04
approved by: AR	revision: 2.3

# Technical Information

ModSTACK™ HD

# 6MS30017E43W33015



## Preliminary data

### Controller interface

Driver and interface board	ref. to separate Application Note		DR110			
			min.	typ.	max.	
Auxiliary voltage		$V_{aux}$	18	24	30	V
Auxiliary power requirement	$V_{aux} = 24\text{ V}$	$P_{aux}$		40		W
Digital input level	resistor to GND 1.8 kΩ, capacitor to GND 4 nF, logic high = on, min. 15 mA	$V_{in\ low}$	0		4	V
		$V_{in\ high}$	11		15	V
Digital output level	open collector, logic low = no fault, max. 15 mA	$V_{out\ low}$	0		1.5	V
		$V_{out\ high}$		15		V
Analog current sensor output inverter section	load max 1 mA, @ 1800 A <sub>RMS</sub>	$V_{IU\ ana2}$ $V_{IV\ ana2}$ $V_{IW\ ana2}$	4.1	4.2	4.3	V
Analog DC link voltage sensor output	load max 1 mA, @ 1100 V	$V_{DC\ ana}$	7.7	7.9	8.1	V
Analog temperature sensor output inverter section (NTC)	load max 1 mA, @ $T_{NTC} = 62\text{ °C}$ , corresponds to $T_j = 135\text{ °C}$ at rated conditions	$V_{Theta\ NTC2}$		7.2		V
Analog temperature sensor output inverter section (Simulated)	load max 1 mA, @ $T_{NTC} = 62\text{ °C}$ , corresponds to $T_j = 135\text{ °C}$ at rated conditions	$V_{Theta\ sim2}$		8.9		V
Over temperature shutdown inverter section		$V_{Error\ OT2}$		9.2		V

### System data

			min.	typ.	max.	
EMC robustness	according to IEC 61800-3 at named interfaces	power	$V_{Burst}$		2	kV
		control	$V_{Burst}$		1	kV
		aux (24V)	$V_{surge}$		1	kV
Storage temperature		$T_{stor}$	-40		80	°C
Operational ambient temperature	PCB, DC link capacitor, bus bar, excluding cooling medium	$T_{op\ amb}$	-25		55	°C
Cooling air velocity	PCB, DC link capacitor, bus bar, standard atmosphere	$V_{air}$	2			m/s
Humidity	no condensation	Rel. F	0		95	%
Vibration	according to IEC 60721				5	m/s <sup>2</sup>
Shock	according to IEC 60721				40	m/s <sup>2</sup>
Protection degree			IP00			
Pollution degree			2			
Dimensions	width x depth x height		1090	596	339	mm
Weight				137		kg

prepared by: AV	date of publication: 2012-04-04
approved by: AR	revision: 2.3

# Technical Information

ModSTACK™ HD

# 6MS30017E43W33015



## Preliminary data

### Heatsink water cooled

			min.	typ.	max.	
Water flow	according to coolant specification from Infineon	$\Delta V/\Delta t$	45			dm <sup>3</sup> /min
Water pressure					8	bar
Water pressure drop	at 45 dm <sup>3</sup> /min water flow	$\Delta p$		200		mbar
Coolant inlet temperature		$T_{inlet}$	-40		55	°C
Thermal resistance heatsink to ambient	per switch	$R_{th,ha}$		0.03		K/W
Cooling channel material			Aluminum			

#### Notes

Composition of coolant: Water and 52 vol. % Antifrogen N

### Overview of optional components

	Unit 1 (not installed)	Inverter Section	Unit 3 (not installed)
Parallel interface board			
Optical interface board			
Voltage sensor		x	
Current sensor		x	
Temperature sensor		x	
Temperature simulation		x	
DC link capacitors		x	
Collector-emitter Active Clamping		x	

#### Notes

Setting of Active Clamping TVS-Diodes:  $V_Z = 1280 \text{ V}$

prepared by: AV	date of publication: 2012-04-04
approved by: AR	revision: 2.3

Preliminary data

$f_{AC\ sine}$  - derating curve IGBT (motor), Diode (generator)  
 $V_{DC} = 1100\ V$ ,  $V_{AC} = 690\ V_{RMS}$ ,  $f_{sw} = 3\ kHz$ ,  $\cos\phi = \pm 0.85$ ,  
 $T_{inlet} = 40\ ^\circ C$  and nom. cooling conditions

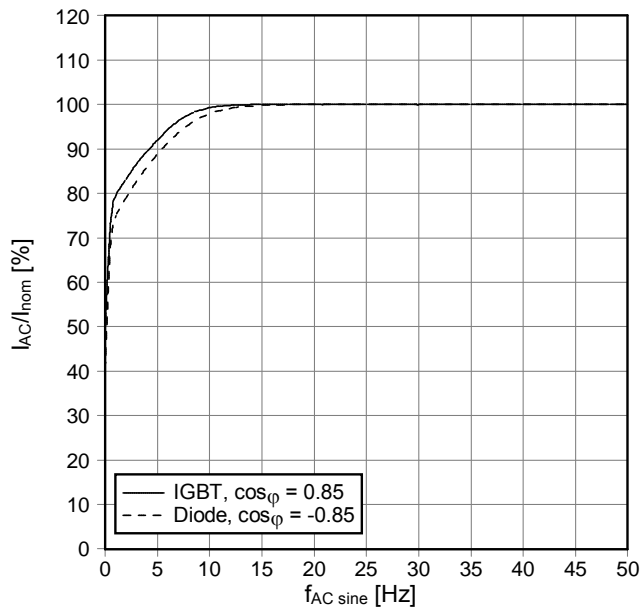

$f_{sw}$  - derating curve IGBT (motor), Diode (generator)  
 $V_{DC} = 1100\ V$ ,  $V_{AC} = 690\ V_{RMS}$ ,  $f_{AC\ sine} = 50\ Hz$ ,  $\cos\phi = \pm 0.85$ ,  
 $T_{inlet} = 40\ ^\circ C$  and nom. cooling conditions

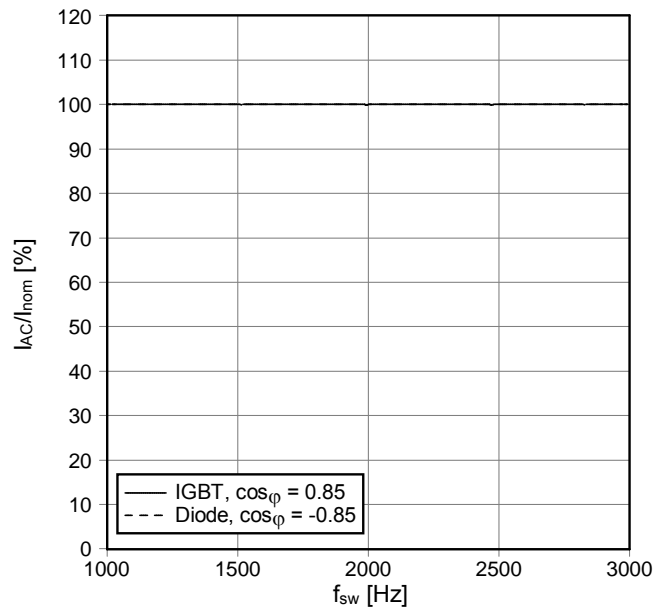

$T_{inlet}$  - derating curve IGBT (motor), Diode (generator)  
 $V_{DC} = 1100\ V$ ,  $V_{AC} = 690\ V_{RMS}$ ,  $f_{sw} = 3\ kHz$ ,  $f_{AC\ sine} = 50\ Hz$ ,  
 $\cos\phi = \pm 0.85$  and nom. cooling conditions

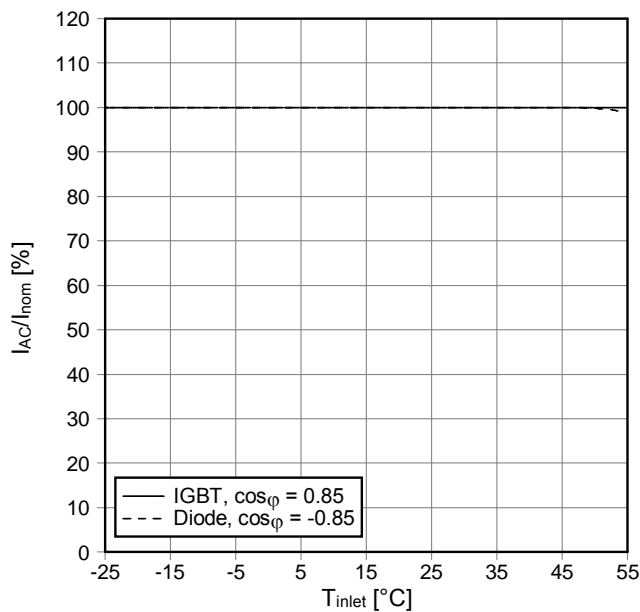

Analog temperature sensor output  $V_{Theta\ NTC}$   
 Sensing NTC of IGBT module

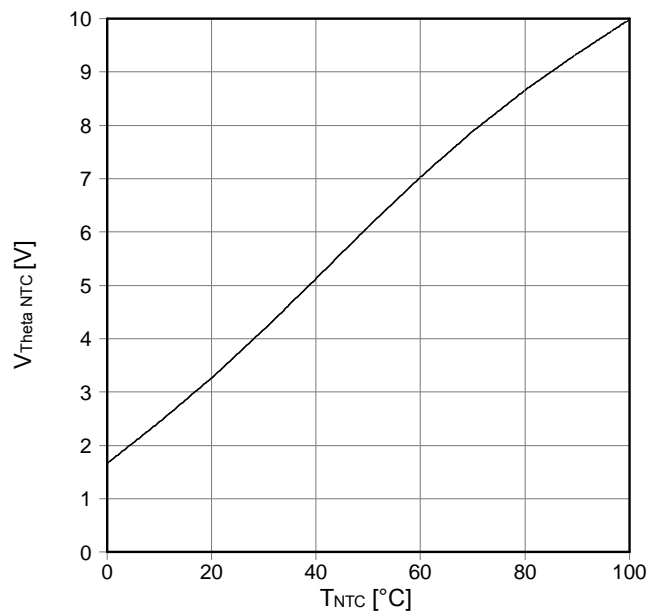

prepared by: AV	date of publication: 2012-04-04
approved by: AR	revision: 2.3

Preliminary data

$T_{vj, sim}$  vs.  $I_{AC}$  - Simulated junction temperatur  
 $V_{DC} = 1100\text{ V}$ ,  $V_{AC} = 690\text{ V}_{RMS}$ ,  $f_{sw} = 3\text{ kHz}$ ,  
 $T_{inlet} = 40\text{ °C}$  and nom. cooling conditions

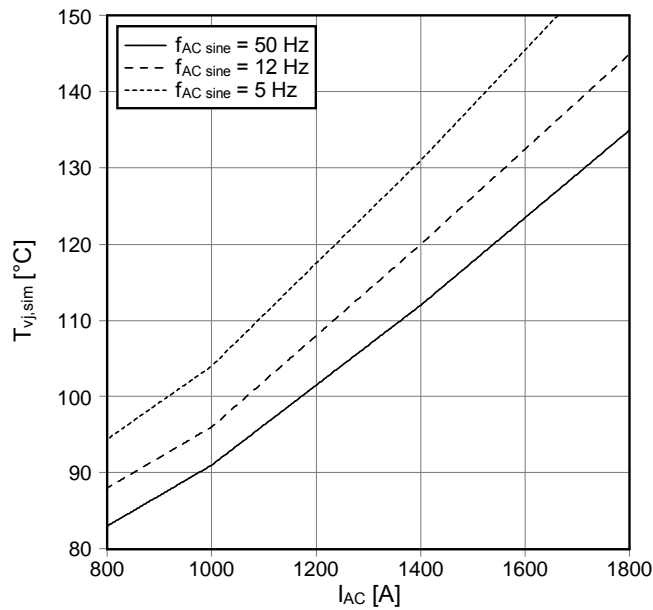

Analog temperature sensor output  $V_{Theta sim}$   
 $V_{DC} = 1100\text{ V}$ ,  $V_{AC} = 690\text{ V}_{RMS}$ ,  $f_{sw} = 3\text{ kHz}$ ,  
 nom. cooling conditions

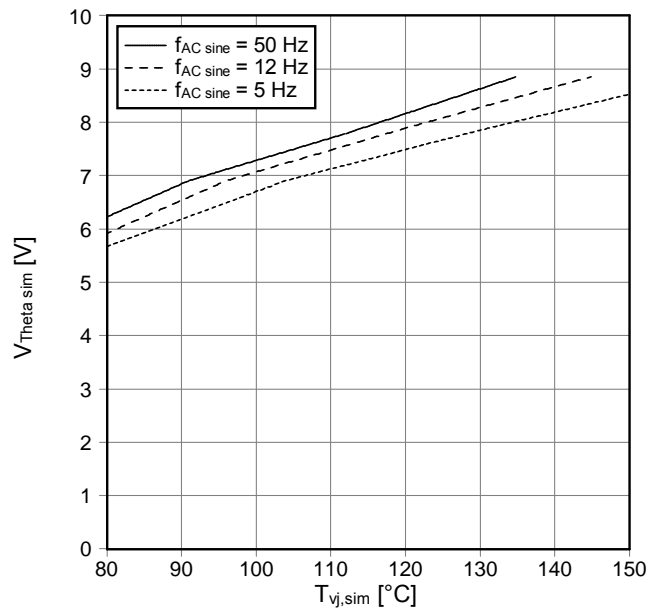

$Z_{th, ha}$  - thermal impedance heatsink to ambient per switch  
 nom. cooling conditions

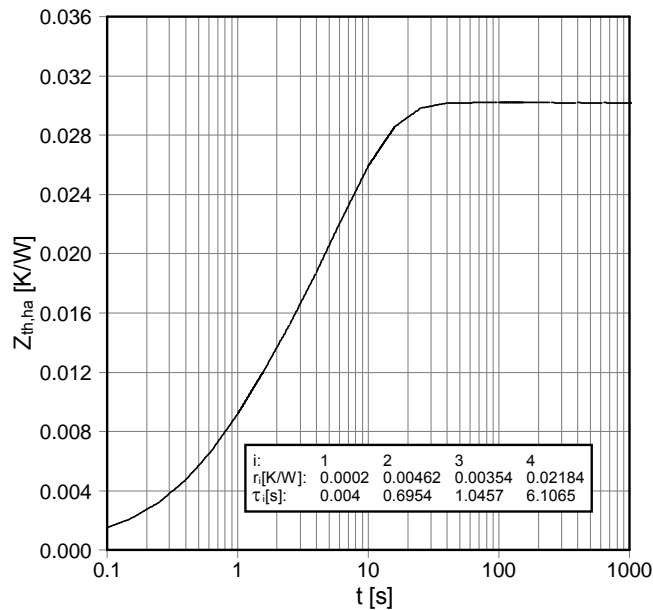

prepared by: AV	date of publication: 2012-04-04
approved by: AR	revision: 2.3

Mechanical drawing

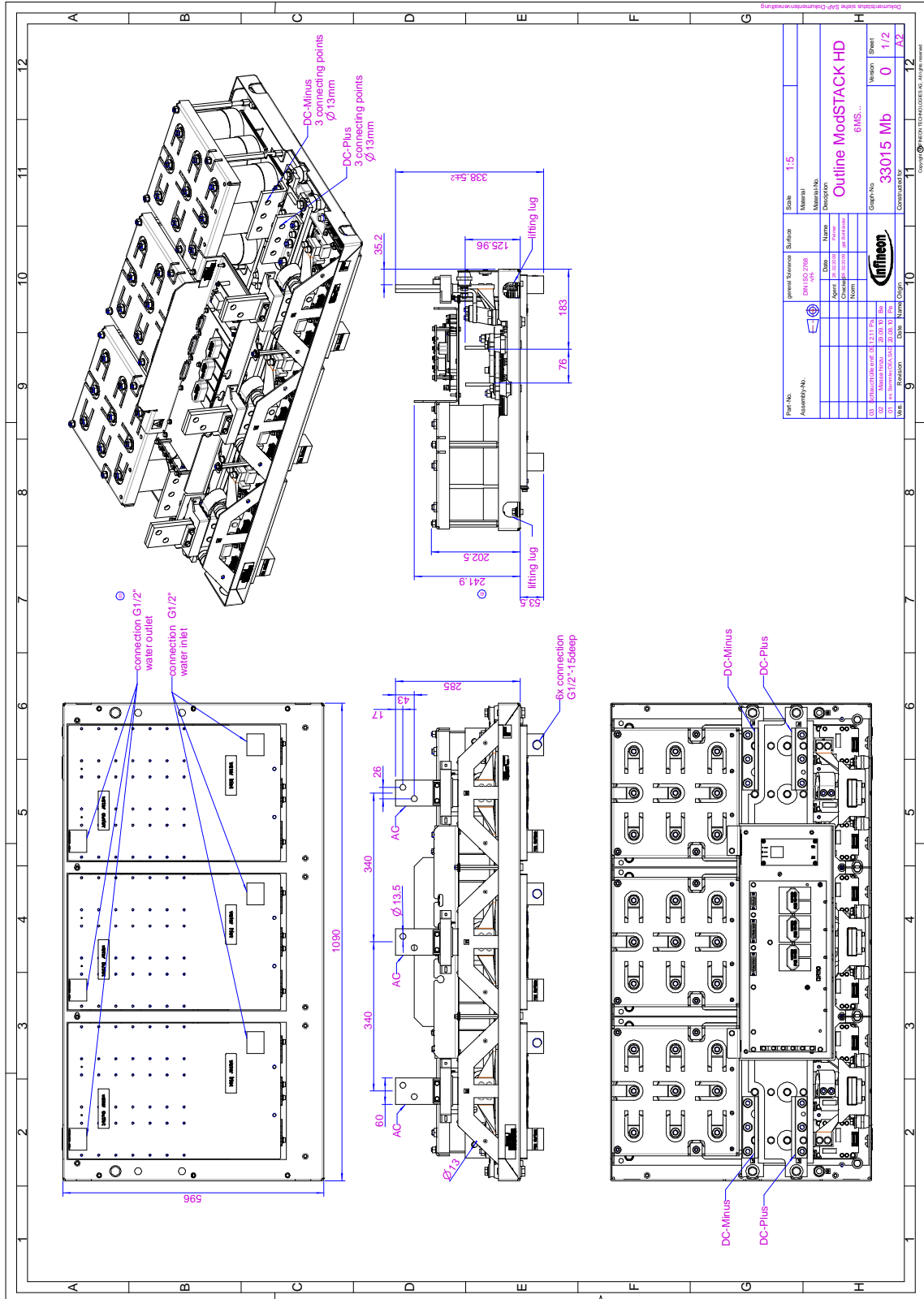

prepared by: AV  
approved by: AR

date of publication: 2012-04-04  
revision: 2.3

Circuit diagram

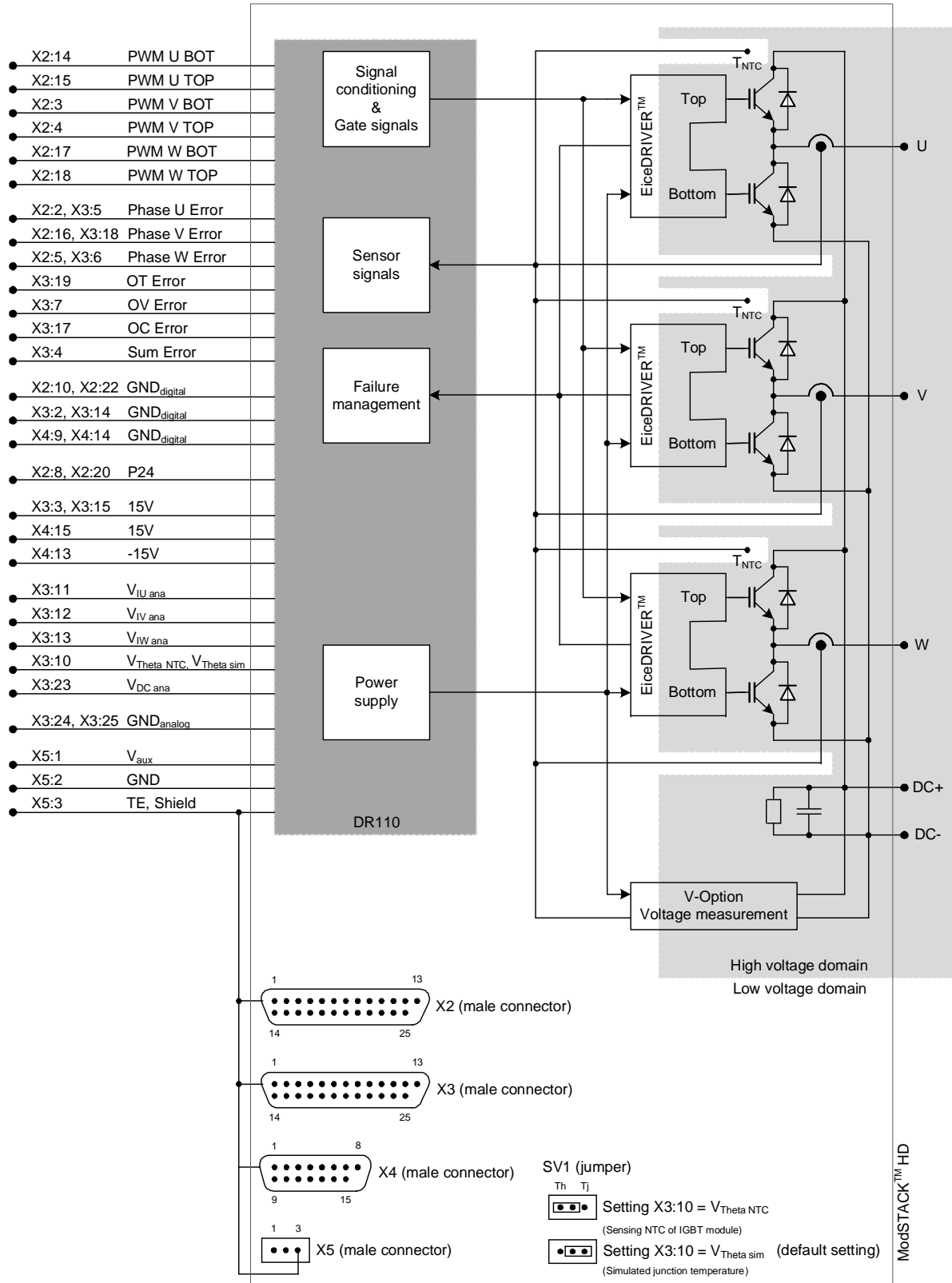

prepared by: AV	date of publication: 2012-04-04
approved by: AR	revision: 2.3



# Technical Information

ModSTACK™ HD

# 6MS30017E43W33015



**Preliminary data**

## Terms & Conditions of usage

The data contained in this product data sheet is exclusively intended for technically trained staff. You and your technical departments will have to evaluate the suitability of the product for the intended application and the completeness of the product data with respect to such application.

This product data sheet is describing the characteristics of this product for which a warranty is granted. Any such warranty is granted exclusively pursuant the terms and conditions of the supply agreement. There will be no guarantee of any kind for the product and its characteristics.

Should you require product information in excess of the data given in this product data sheet or which concerns the specific application of our product, please contact the sales office, which is responsible for you (see [www.infineon.com](http://www.infineon.com), sales&contact). For those that are specifically interested we may provide application notes.

Due to technical requirements our product may contain dangerous substances. For information on the types in question please contact the sales office, which is responsible for you.

Should you intend to use the Product in aviation applications, in health or live endangering or life support applications, please notify. Please note, that for any such applications we urgently recommend

- to perform joint Risk and Quality Assessments;
- the conclusion of Quality Agreements;
- to establish joint measures of an ongoing product survey, and that we may make delivery depended on the realization of any such measures.

If and to the extent necessary, please forward equivalent notices to your customers.

Changes of this product data sheet are reserved.

## Safety Instructions

Prior to installation and operation, all safety notices and warnings and all warning signs attached to the equipment have to be carefully read. Make sure that all warning signs remain in a legible condition and that missing or damaged signs are replaced. To installation and operation, all safety notices and warnings and all warning signs attached to the equipment have to be carefully read. Make sure that all warning signs remain in a legible condition and that missing or damaged signs are replaced.

prepared by: AV	date of publication: 2012-04-04
approved by: AR	revision: 2.3