

# NBA3N206SDGEVB

## NBA3N206SDGEVB Evaluation Board User's Manual



ON Semiconductor®

[www.onsemi.com](http://www.onsemi.com)

### EVAl BOARD USER'S MANUAL

#### Introduction

The NBA3N206S is a 3.3 V differential Multipoint (M-LVDS) line Driver and Receiver. NBA3N206S supports Simplex or Half Duplex bus configurations.

The NBA3N206S has Type-2 receivers that detect the bus state with as little as 50 mV of differential input voltage over a common-mode voltage range of -1 V to 3.4 V. Type-2 receivers include an offset threshold of 0.1 V to provide a detectable voltage under open-circuit, idle-bus, and other fault conditions.

The NBA3N206SDGEVB evaluation board was developed to accommodate the NBA3N206S device. This evaluation board was designed to provide a flexible and convenient platform to quickly evaluate, characterize and verify the operation of the NBA3N206S.

This manual should be used in conjunction with the device datasheet which contains full technical details on the device specifications and operation.

#### Evaluation Board User's Manual Contents:

- NBA3N206S Evaluation Board Information
- Board Features
- Board Layout Map
- Test and Measurement Setup Procedures
- Board Schematic and Bill of Materials

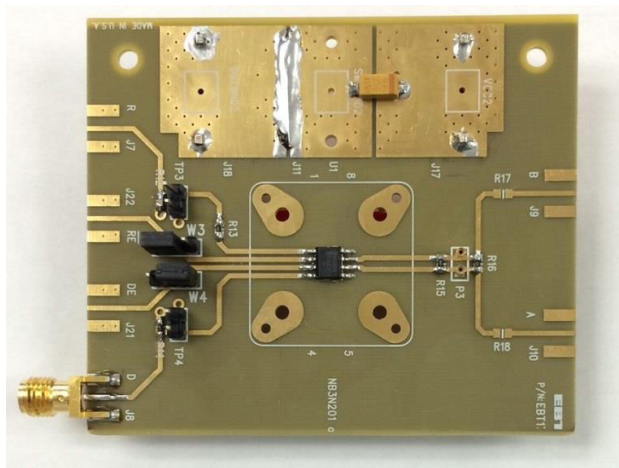

Top View

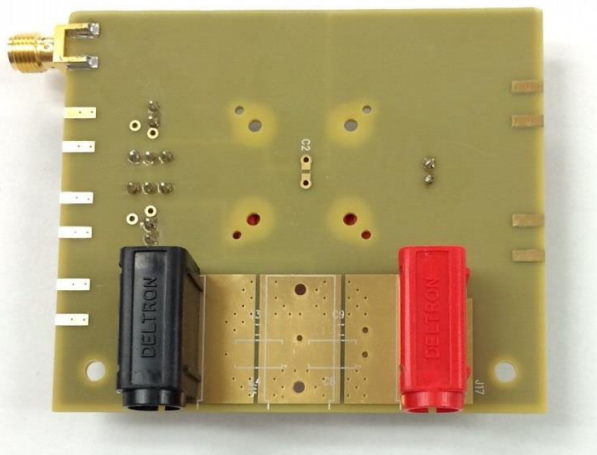

Bottom View

Figure 1. NBA3N206SDGEVB Evaluation Board

# NBA3N206SDGEVB

## Section 1: Board Features

- Board supplied includes an 8–Pin SOIC.
- Board is configured to operate from a single VCC supply and a single GND supply.
- Single–ended and differential inputs/outputs are accessed via SMA connectors or high impedance probes.
- Board may be configured for bus operation as:
  1. Point–to–Point with Simplex Single Termination
  2. Point–to–Point with Simplex Parallel Termination
  3. Multipoint Two–Node with Single Termination
  4. Multipoint Two–Node with Parallel Termination
- Two 100 Ω Parallel Termination resistors are mounted on each bus (Driver/Receiver) transceiver I/O pin pair. Resistors may be removed for added configuration flexibility.
- All layers are constructed with FR4 dielectric material.
- The first layer is the primary signal layer, including all of the differential inputs and outputs.
- The second layer is a ground plane. It is dedicated for the SMA ground plane.
- The third layer is a dedicated power plane. A portion of the 3<sup>rd</sup> layer is designated for the device VCC and DUTGND power planes.

## Layer Stack

The NBA3N206SDGEVB SOIC–8 Evaluation Board provides a high bandwidth, 50 Ω controlled trace impedance environment (100 Ω line–to–line differential) and is implemented in four layers.

- L1 (Top) Signal
- L2 SMA Ground
- L3 VCC and DUT Ground
- L4 (Bottom) Power Supply Bypass Capacitors, Control Pin Traces and Banana Jacks

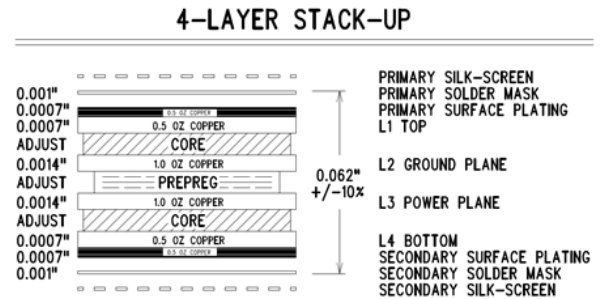

Figure 2. Four Layer Stack-up

## Section 2: Board Layout Map

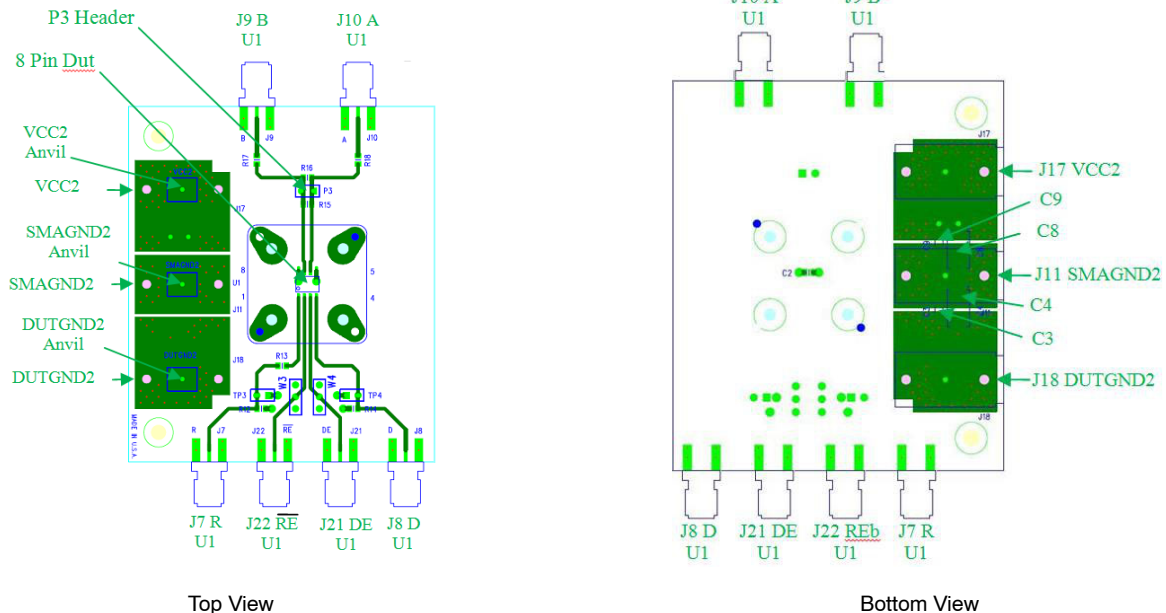

Figure 3. NBA3N206SDGEVB Evaluation Board

# NBA3N206SDGEVB

**Table 1. LOAD BOARD CONNECTIONS AND COMPONENTS**

Board	Transceiver	Device Pin	Function
VCC2	U1 (8 Pin)	U1 Pin 8	VCC2 Power Supply connection point to U1
VCC2 Anvil	U1 (8 Pin)	U1 Pin 8	Alternative connection point for VCC2
SMAGND2	U1 (8 Pin)	-	U1 SMA (J7/8/9/10/21/22) ground shields connection point
SMAGND2 Anvil	U1 (8 Pin)	-	Alternative connection point for U1 SMA shields
DUTGND2	U1 (8 Pin)	U1 Pin 5	U1 DUT ground pin
DUTGND2 Anvil	U1 (8 Pin)	U1 Pin 5	Alternative connection point for U1 DUT ground pin
J7 R	U1 (8 Pin)	U1 Pin 1	U1 R input (Note 1)
J8 D	U1 (8 Pin)	U1 Pin 4	U1 D input
J9 B	U1 (8 Pin)	U1 Pin 7	U1 B input/output (Note 1)
J10 A	U1 (8 Pin)	U1 Pin 6	U1 B input/output (Note 1)
J21 DE	U1 (8 Pin)	U1 Pin 3	U1 DE input (Note 1)
J22 REb	U1 (8 Pin)	U1 Pin 2	U1 REb input (Note 1)
P3 Header	U1 (8 Pin)	U1 Pins 6, 7	U2 Connection Header for A & B
TP3	U1 (8 Pin)	U1 Pin 1	Test Point for U1 R input
TP4	U1 (8 Pin)	U1 Pin 4	Test Point for U1 D input
W3 Pad	U1 (8 Pin)	U1 Pin 2	Program point for U1 Reb
W4 Pad	U1 (8 Pin)	U1 Pin 3	Program point for U1 DE
*R12	U1 (8 Pin)	U1 Pin 1	U1 15pF R pin
R13	U1 (8 Pin)	U1 Pin 1	U1 0 $\Omega$ R pin
R14	U1 (8 Pin)	U1 Pin 4	U1 D input optional termination location
R15	U1 (8 Pin)	U1 Pins 6, 7	U1 100 $\Omega$ termination location
R16	U1 (8 Pin)	U1 Pins 6, 7	U1 100 $\Omega$ termination location
R17	U1 (8 Pin)	U1 Pins 7	U1 0 $\Omega$ A pin
R18	U1 (8 Pin)	U1 Pins 6	U1 0 $\Omega$ B pin

\*Replaced with  $C_L=15\text{pF}$  capacitor

1. Not populated on board

# NBA3N206SDGEVB

## Section 3: Test and Management Setup Procedures

### Basic Operation Setup

1. Set VCC to 3.3V
2. Set DE, Move Jumper to Logic High
3. Set REb, Move Jumper to Logic Low
4. Apply LVCMOS Input Signal to D. (See datasheet for appropriate levels)
5. Monitor Differential Bus Voltage  $V_{AB}$  with a *Differential Probe*
6. Monitor Receiver Output  $V_R$  with a *Hi-Z Probe*

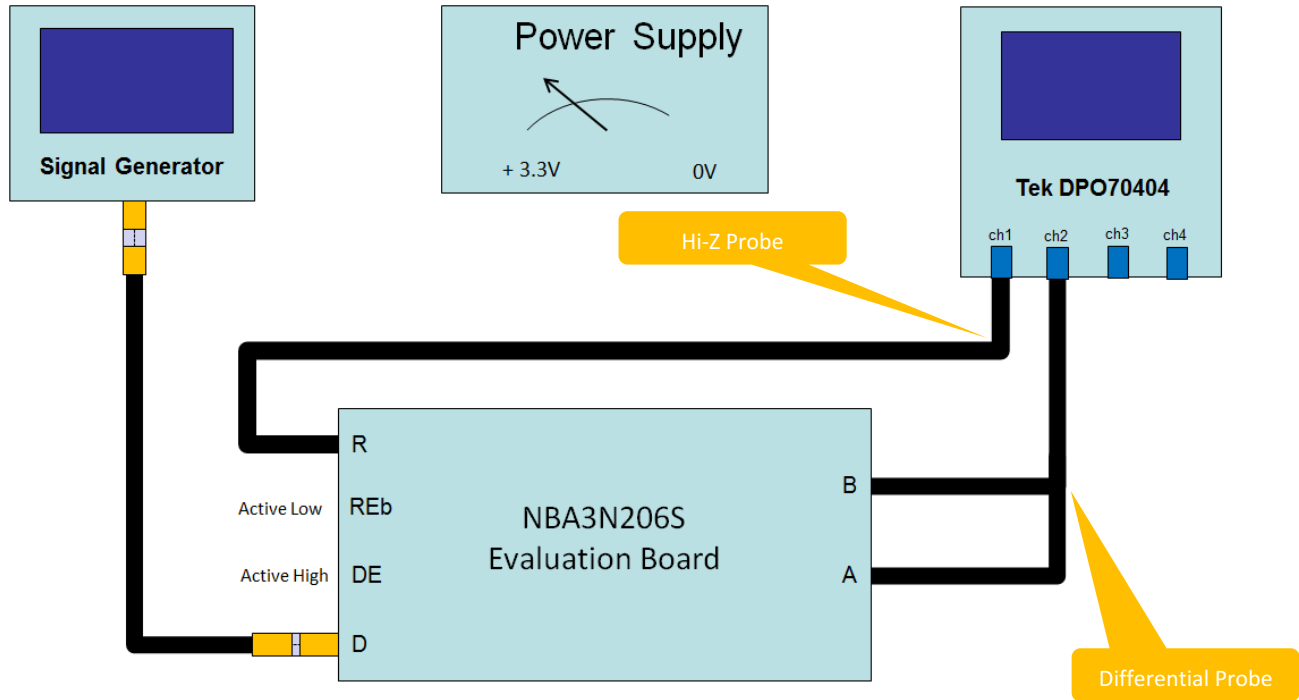

Figure 4. NBA3N206S Evaluation Board Test Block Diagram

### Equipment Used (or equivalent)

1. Generator (HP 8133A or similar)
2. Oscilloscope (Tektronix TDS8000 or similar)
3. Power Supply (Agilent #6624A DC or similar)
4. Digital Voltmeter
5. Differential Probe
6. Hi-Z Probe

# NBA3N206SDGEVB

## Test Configurations

**Simplex Theory Configurations:** Data flow is unidirectional and Point-to-Point from one Driver to one Receiver. NBA3N206SDG devices provide a high signal current allowing long drive runs and high noise immunity. Single terminated interconnects yield high amplitude levels.

Parallel terminated interconnects yield typical MLVDS amplitude levels and minimize reflections. See Figures 5 and 6. NBA3N206SDG can be used as a driver or as a receiver.

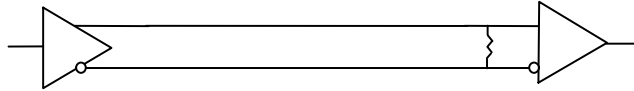

Figure 5. Point-to-Point Simplex Single Termination

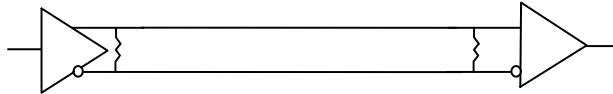

Figure 6. Parallel-Terminated Simplex

**Simplex Multidrop Theory Configurations:** Data flow is unidirectional from one Driver with one or more Receivers (Multiple boards required). Single terminated interconnects yield high amplitude levels. Parallel terminated interconnects yield typical MLVDS amplitude

levels and minimize reflections. Header P3 may be used as needed to interconnect transceivers to each other or to a bus. See Figures 1, 7, and 8. A NBA3N206SDG can be used as the driver or as a receiver.

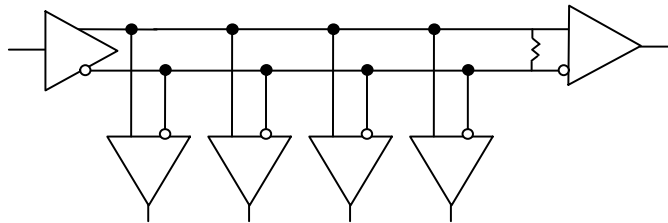

Figure 7. Multidrop or Distributed Simplex with Single Termination

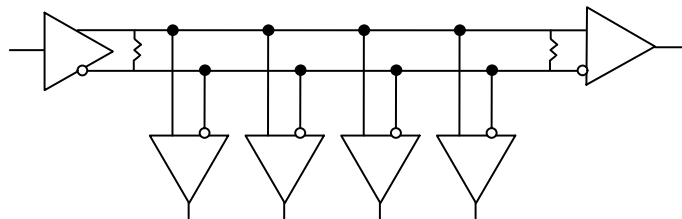

Figure 8. Multidrop or Distributed Simplex with Double Termination

**Half Duplex Multinode Multipoint Theory Configurations:** Data flow is unidirectional and selected from one of multiple possible Drivers to multiple Receives. One “Two Node” multipoint connection can be accomplished with a single board. Multipoint connection with more than two nodes require multiple boards. Parallel

terminated interconnects yield typical MLVDS amplitude levels and minimize reflections. Header P3 may be used as needed to interconnect transceivers to each other or to a bus. See Figure 9. NBA3N206SDG can be used as a driver or as a receiver.

## NBA3N206SDGEVB

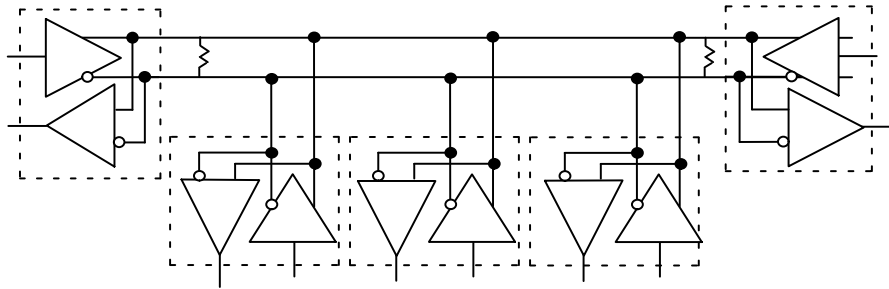

Figure 9. Multinode Multipoint Half Duplex (requires Double Termination)

### Output Waveforms

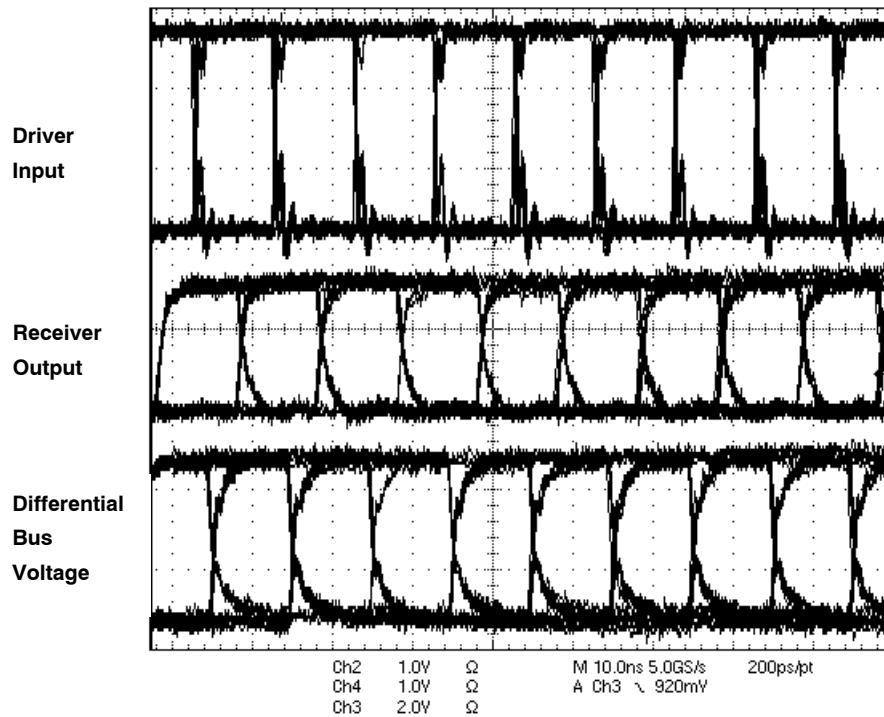

Figure 10. High Impedance Output Termination

Figure 10 shows typical NBA3N206S waveforms. The Driver Input is supplied by a 100 Mbps data signal via an HP8133A generator. The Receiver Output ( $V_R$ ) can be

monitored using a *Hi-Z probe*; the Differential Bus Voltage ( $V_{AB}$ ) can be monitored using a *Differential probe*.

# NBA3N206SDGEVB

## Section 4: Board Schematic and Bill of Materials

### Board Schematic

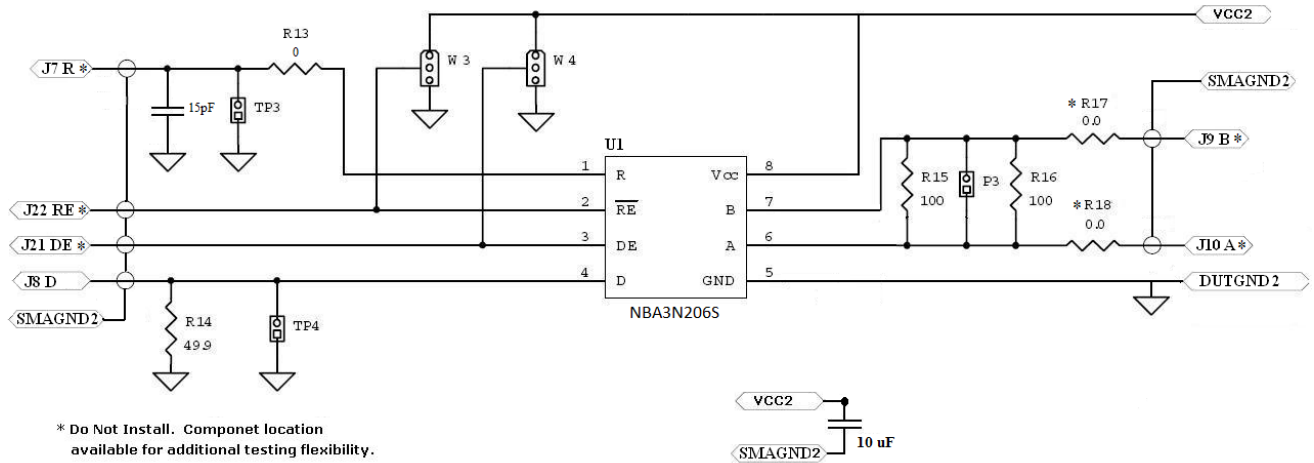

Figure 11. Board Schematic

Table 2. BILL OF MATERIALS AND LAMINATION STACKUP

Component Designation	Case	Value	Manufacturer	Part Number	Description	Qty
U1			ON Semiconductor	NBA3N206S		1
J18			Deltron	571-0100	Banana Jacks – Black	1
J17			Deltron	571-0500	Banana Jacks – Red	1
J8			Johnson	#142-0711-821	SMA Connector Side Launch Narrow	1
P3			AMP	4-103239-0x2	Header (make from 4-103239-0)	1
VCC2, SMAGND2, DUTGND2			Keystone	5015	Anvil Clips	6
W3, W4			FCI	68000-103HLF	3 Pin Header	2
TP3, TP4			3M	961102-6404-AR	2 Pin Header	2
R14	O603	50 Ω	Panasonic		Precision Thick Film Chip Resistor	1
R15, R16	O603	100 Ω	Panasonic		Precision Thick Film Chip Resistor	2
R13, R17, R18	O603	0 Ω	Panasonic		Precision Thick Film Chip Resistor	1
C4		10 μF	KEMET	C1210X106K3RACTU	Chip Capacitor	1
C11	O603	15 pF	Murata	GRM1555C1E150JA01D	Chip Capacitor	1

ON Semiconductor and the ON Semiconductor logo are trademarks of Semiconductor Components Industries, LLC dba ON Semiconductor or its subsidiaries in the United States and/or other countries. ON Semiconductor owns the rights to a number of patents, trademarks, copyrights, trade secrets, and other intellectual property. A listing of ON Semiconductor's product/patent coverage may be accessed at [www.onsemi.com/site/pdf/Patent-Marking.pdf](http://www.onsemi.com/site/pdf/Patent-Marking.pdf). ON Semiconductor is an Equal Opportunity/Affirmative Action Employer. This literature is subject to all applicable copyright laws and is not for resale in any manner.

The evaluation board/kit (research and development board/kit) (hereinafter the "board") is not a finished product and is as such not available for sale to consumers. The board is only intended for research, development, demonstration and evaluation purposes and should as such only be used in laboratory/development areas by persons with an engineering/technical training and familiar with the risks associated with handling electrical/mechanical components, systems and subsystems. This person assumes full responsibility/liability for proper and safe handling. Any other use, resale or redistribution for any other purpose is strictly prohibited.

The board is delivered "AS IS" and without warranty of any kind including, but not limited to, that the board is production-worthy, that the functions contained in the board will meet your requirements, or that the operation of the board will be uninterrupted or error free. ON Semiconductor expressly disclaims all warranties, express, implied or otherwise, including without limitation, warranties of fitness for a particular purpose and non-infringement of intellectual property rights.

ON Semiconductor reserves the right to make changes without further notice to any board.

You are responsible for determining whether the board will be suitable for your intended use or application or will achieve your intended results. Prior to using or distributing any systems that have been evaluated, designed or tested using the board, you agree to test and validate your design to confirm the functionality for your application. Any technical, applications or design information or advice, quality characterization, reliability data or other services provided by ON Semiconductor shall not constitute any representation or warranty by ON Semiconductor, and no additional obligations or liabilities shall arise from ON Semiconductor having provided such information or services.

The boards are not designed, intended, or authorized for use in life support systems, or any FDA Class 3 medical devices or medical devices with a similar or equivalent classification in a foreign jurisdiction, or any devices intended for implantation in the human body. Should you purchase or use the board for any such unintended or unauthorized application, you shall indemnify and hold ON Semiconductor and its officers, employees, subsidiaries, affiliates, and distributors harmless against all claims, costs, damages, and expenses, and reasonable attorney fees arising out of, directly or indirectly, any claim of personal injury or death associated with such unintended or unauthorized use, even if such claim alleges that ON Semiconductor was negligent regarding the design or manufacture of the board.

This evaluation board/kit does not fall within the scope of the European Union directives regarding electromagnetic compatibility, restricted substances (RoHS), recycling (WEEE), FCC, CE or UL, and may not meet the technical requirements of these or other related directives.

**FCC WARNING** – This evaluation board/kit is intended for use for engineering development, demonstration, or evaluation purposes only and is not considered by ON Semiconductor to be a finished end product fit for general consumer use. It may generate, use, or radiate radio frequency energy and has not been tested for compliance with the limits of computing devices pursuant to part 15 of FCC rules, which are designed to provide reasonable protection against radio frequency interference. Operation of this equipment may cause interference with radio communications, in which case the user shall be responsible, at its expense, to take whatever measures may be required to correct this interference.

ON Semiconductor does not convey any license under its patent rights nor the rights of others.

**LIMITATIONS OF LIABILITY:** ON Semiconductor shall not be liable for any special, consequential, incidental, indirect or punitive damages, including, but not limited to the costs of requalification, delay, loss of profits or goodwill, arising out of or in connection with the board, even if ON Semiconductor is advised of the possibility of such damages. In no event shall ON Semiconductor's aggregate liability from any obligation arising out of or in connection with the board, under any theory of liability, exceed the purchase price paid for the board, if any.

For more information and documentation, please visit [www.onsemi.com](http://www.onsemi.com).

---

## PUBLICATION ORDERING INFORMATION

### LITERATURE FULFILLMENT:

Email Requests to: [orderlit@onsemi.com](mailto:orderlit@onsemi.com)

ON Semiconductor Website: [www.onsemi.com](http://www.onsemi.com)

### TECHNICAL SUPPORT

North American Technical Support:

Voice Mail: 1 800-282-9855 Toll Free USA/Canada

Phone: 011 421 33 790 2910

Europe, Middle East and Africa Technical Support:

Phone: 00421 33 790 2910

For additional information, please contact your local Sales Representative